



MANUFACTURED BY:
Backyard Discovery
3305 Airport Drive, Pittsburg, KS 66762
800-856-4445

Basepoint Business Centre: Rivermead Drive, Westlea, Swindon SN5 7EX Phone: 0800-118-2476
J.P. Coenstraat 7, The Bridge, The Hague, 2595 WP, Netherlands Phone: 0800-567-8990

CARIBBEAN

Swing Set

Model # 1606029

The assembly manual must be retained since it contains important information



WARNING

Adult Assembly Required.

Not suitable for children under 36 months due to small parts.

FOR DOMESTIC USE ONLY. INTENDED FOR OUTDOOR USE.



Please visit www.backyarddiscovery.com

For the most up to date assembly manual, to register your set, or to order replacement parts

Para obtener instrucciones en español, visite www.backyarddiscovery.com



EASY STEP-BY-STEP
3D INTERACTIVE INSTRUCTIONS

DOWNLOAD THE FREE APP

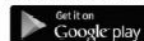

Made in China

INS-1606029-A-CARIBBEAN-ENG 08/10/23

Basic Setup Dimensions

Place the set on level ground, not less than 6 ft [2 m] from any structure or obstruction such as a fence, garage, house, overhanging branches, laundry lines, or electrical wires.

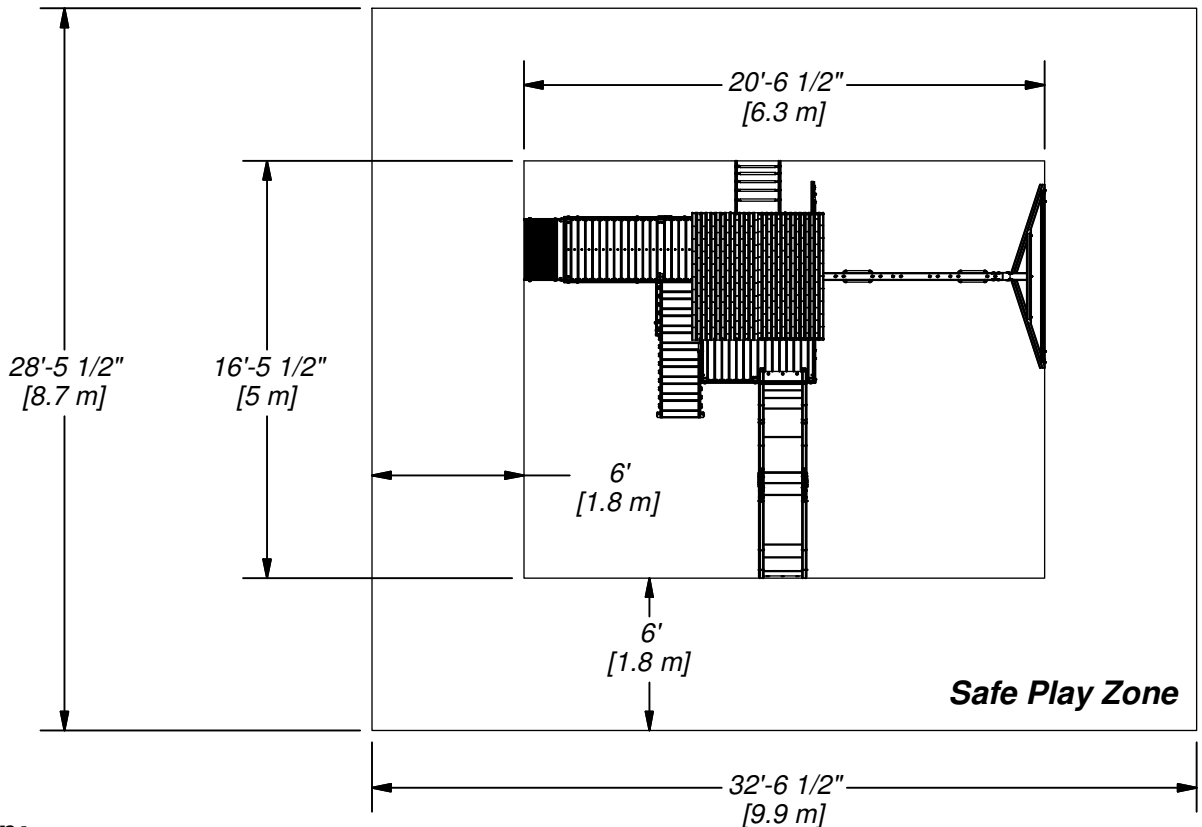

General Information:

Your set has been designed and engineered for children only and for residential use only.
 A maximum of 150 lbs. per child is recommended for play activities designed for individual use.
 A maximum of 120 lbs. per child is recommended for play activities designed for multiple child use.
 A maximum of 9 children is recommended for this swing set.

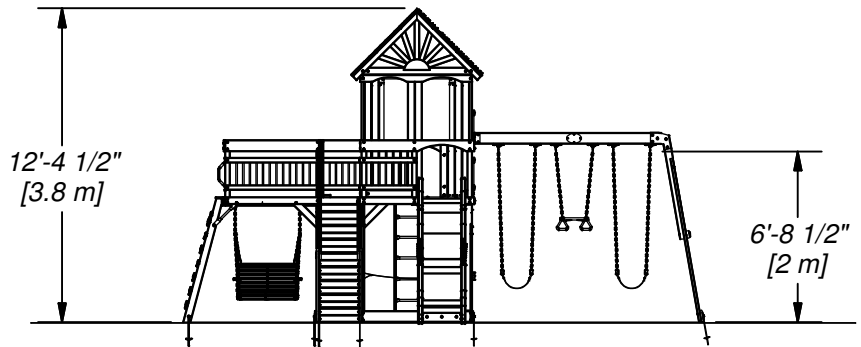

Safe play height: 18'-5" [5.6 m]
 Maximum fall height: 6'-8 1/2" [2 m]

Important Assembly Notes

- 1) While assembling unit, take time before and after each phase to make sure fort is level. If fort is not level, assembly will be difficult and improper assembly may result. Extra care must be taken to ensure the fort is square.
- 2) Tighten bolts securely, tighten nuts on bolts flush to the tube or member.
- 3) Pay close attention to the ITEMS NEEDED FOR EACH PHASE. They can be a valuable aid when sorting your wood and hardware. Assembly will be made easier if items are sorted by phase.
- 4) Pay close attention to make sure you are using the correct hardware in the correct phases. Using incorrect hardware may result in improper assembly.
- 5) Whenever a T-nut is used, follow these directions. Place T-nut in pre-drilled hole. Tap in with hammer. Place bolt with washers in the opposite side. Hand tighten to make sure the bolt is in the T-nut. DO NOT over tighten.
- 6) Read the steps of each phase thoroughly. The written steps may include important information not shown in the illustrations.

Parts Identification

Wood Components

(NOT TO SCALE)



(1) **A50 - SWING BEAM - W4L06169**
3 3/8"x5 1/4"x89 1/2" (86x134x2274)

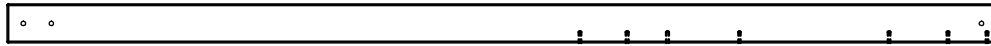

(1) **E1 - UPRIGHT - W4L06195**
1 3/8"x3 3/8"x86 1/8" (36x86x2186)



(1) **E2 - UPRIGHT - W4L06190**
1 3/8"x3 3/8"x86 1/8" (36x86x2186)

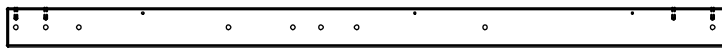

(1) **E3 - UPRIGHT - W4L06069**
1 3/8"x3 3/8"x63" (36x86x1600)

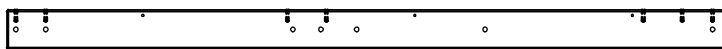

(1) **E4 - UPRIGHT - W4L06085**
1 3/8"x3 3/8"x63" (36x86x1600)

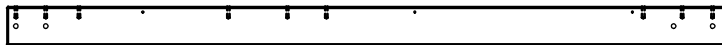

(1) **E5 - UPRIGHT - W4L06090**
1 3/8"x3 3/8"x63" (36x86x1600)



(1) **E6 - UPRIGHT - W4L06091**
1 3/8"x3 3/8"x63" (36x86x1600)

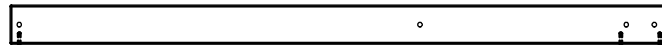

(1) **E7 - UPRIGHT - W4L06051**
1 3/8"x3 3/8"x57 3/8" (36x86x1457)

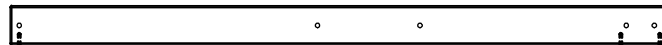

(1) **E8 - UPRIGHT - W4L06058**
1 3/8"x3 3/8"x57 3/8" (36x86x1457)



(1) **E9 - UPRIGHT - W4L06061**
1 3/8"x3 3/8"x57 3/8" (36x86x1457)

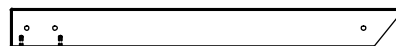

(1) **E10 - UPRIGHT - W4L06053**
1 3/8"x3 3/8"x34 1/4" (36x86x869)

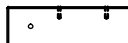

(1) **E11 - UPRIGHT - W4L06127**
1 3/8"x3 3/8"x10 7/8" (36x86x275)



(1) **E13 - FLOOR JOIST - W4L06320**
1 3/8"x3 3/8"x63 3/4" (36x86x1618)

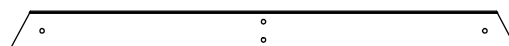

(1) **E50 - END SUPPORT - W4L06172**
1 3/8"x3 3/8"x44 1/8" (36x86x1120)

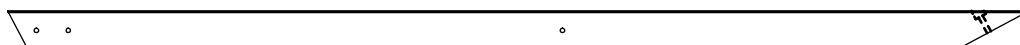

(2) **E51 - ANGLE BRACE - W4L06171**
1 3/8"x3 3/8"x88 3/4" (36x86x2254)

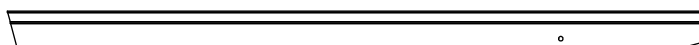

(1) **E72 - LEFT RAIL - W4L06335**
1 3/8"x3 3/8"x61 1/8" (36x86x1553)

Parts Identification

Wood Components

(NOT TO SCALE)

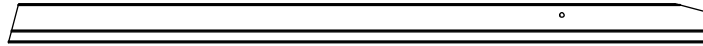

- (1) **E73 - RIGHT RAIL - W4L06336**
1 3/8"x3 3/8"x61 1/8" (36x86x1553)



- (2) **F1 - UPRIGHT - W4L06131**
1 3/8"x2 3/8"x34 7/8" (36x60x887)

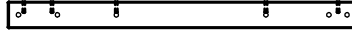

- (1) **F2 - POST - W4L06070**
1 3/8"x2 3/8"x30 3/8" (36x60x772)

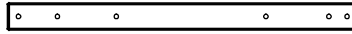

- (1) **F3 - POST - W4L06074**
1 3/8"x2 3/8"x30 3/8" (36x60x772)



- (1) **F4 - POST - W4L06093**
1 3/8"x2 3/8"x30 3/8" (36x60x772)

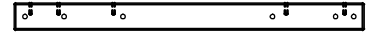

- (2) **F5 - POST - W4L06323**
1 3/8"x2 3/8"x30 3/8" (36x60x772)



- (2) **F6 - FLOOR JOIST - W4L06351**
1 3/8"x2 3/4"x13 7/8" (36x70x352)



- (1) **G1 - WALL RAIL - W4L06086**
1"x5 1/4"x76 3/4" (24x134x1948)

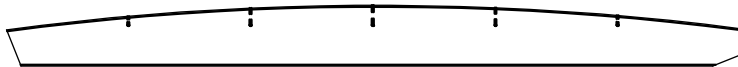

- (2) **G2 - LADDER UPRIGHT - W4L06144**
1"x5 1/4"x64 1/2" (24x134x1637)

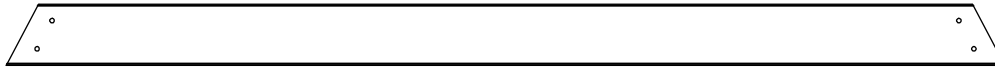

- (1) **G50 - GROUND BOARD - W4L06173**
1"x5 1/4"x86 3/4" (24x134x2202)



- (1) **H1 - HANDRAIL - W4L06132**
1"x3 3/8"x88 3/4" (24x86x2253)



- (1) **H2 - FLOOR SUPPORT - W4L06060**
1"x3 3/8"x76 3/4" (24x86x1948)



- (1) **H3 - FLOOR SUPPORT - W4L06352**
1"x3 3/8"x76 3/4" (24x86x1948)

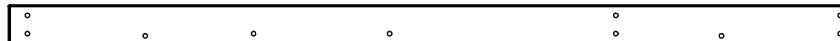

- (1) **H4 - FLOOR SUPPORT - W4L06189**
1"x3 3/8"x73 1/8" (24x86x1858)



- (1) **H5 - SAFETY RAIL - W4L06059**
1"x3 3/8"x68 5/8" (24x86x1742)

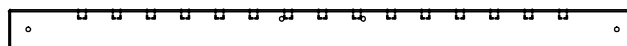

- (1) **H6 - WALL RAIL - W4L06088**
1"x3 3/8"x54 1/2" (24x86x1384)

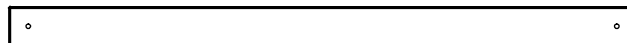

- (2) **H7 - WALL RAIL - W4L06100**
1"x3 3/8"x54 1/2" (24x86x1384)

Parts Identification

Wood Components

(NOT TO SCALE)

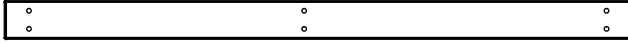

(1) **H8 - FLOOR SUPPORT - W4L06079**
1"x3 3/8"x54 3/8" (24x86x1382)

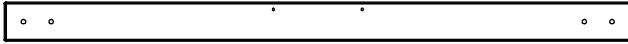

(2) **H9 - WALL RAIL - W4L06102**
1"x3 3/8"x54 3/8" (24x86x1382)



(1) **H10 - FLOOR SUPPORT - W4L06062**
1"x3 3/8"x52 1/2" (24x86x1334)



(1) **H11 - HANDRAIL - W4L06133**
1"x3 3/8"x46" (24x86x1170)



(1) **H12 - FLOOR SUPPORT - W4L06321**
1"x3 3/8"x63 3/4" (24x86x1618)



(1) **H13 - WALL SPACER - W4L06126**
1"x3 3/8"x3 3/8" (24x86x86)

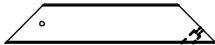

(3) **H22 - DECK BRACE - W4L06082**
1"x3 3/8"x18 3/8" (24x86x466)

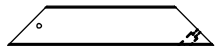

(6) **H23 - DECK BRACE - W4L06179**
1"x3 3/8"x17 7/8" (24x86x453)



(1) **H24 - RIGHT ARM REST - W4L06348**
1"x3 3/8"x19 3/8" (24x86x492)



(3) **H83 - WALL BOARD - W4L06182**
1"x3 3/8"x61 1/4" (24x86x1557)



(1) **H84 - WALL BOARD - W4L06183**
1"x3 3/8"x61 1/4" (24x86x1557)

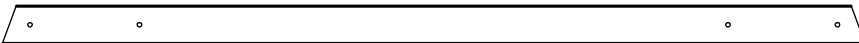

(1) **H85 - SAFETY RAIL - W4L06184**
1"x3 3/8"x75" (24x86x1904)

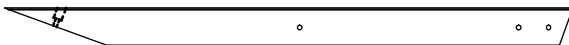

(2) **H86 - ANGLE BRACE - W4L06186**
1"x3 3/8"x49 3/8" (24x86x1254)



(1) **H14 - FLOOR SUPPORT - W4L06193**
1"x3 3/8"x45" (24x86x1142)

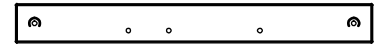

(1) **H15 - FLOOR SUPPORT - W4L06327**
1"x3 3/8"x31" (24x86x788)



(2) **H16 - SWING RAIL SUPPORT - W4L06341**
1"x3 3/8"x9 1/8" (24x86x232)



(2) **H17 - SIDE BACK RAIL - W4L06343**
1"x3 3/8"x18" (24x86x456)



(2) **H18 - SIDE SEAT SUPPORT - W4L06344**
1"x3 3/8"x16 1/8" (24x86x410)



(1) **H19 - CENTER SEAT SUPPORT - W4L06345**
1"x3 3/8"x16 1/8" (24x86x410)



(1) **H20 - CENTER BACK RAIL - W4L06346**
1"x3 3/8"x18" (24x86x456)



(1) **H21 - LEFT ARM REST - W4L06347**
1"x3 3/8"x19 3/8" (24x86x492)

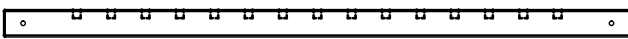

(1) **J1 - WALL RAIL - W4L06104**
1"x2 3/8"x54 1/2" (24x60x1384)

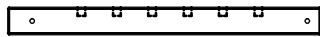

(2) **J3 - WALL RAIL - W4L06092**
1"x2 3/8"x27 1/4" (24x60x691)

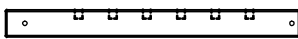

(4) **J6 - WALL RAIL - W4L06089**
1"x2 3/8"x25 5/8" (24x60x650)

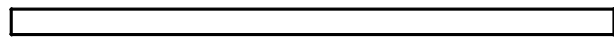

(2) **J2 - FLOOR JOIST - W4L06068**
1"x2 3/8"x52 1/2" (24x60x1334)



(2) **J4 - OUTER CURTAIN ROD HOLDER - W4L05293**
1"x2 3/8"x2 3/8" (24x60x60)



(1) **J5 - INNER CURTAIN ROD HOLDER - W4L05294**
1"x2 3/8"x2 3/8" (24x60x60)

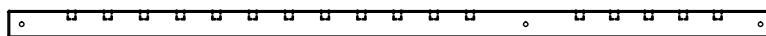

(2) **J7 - WALL RAIL - W4L06192**
1"x2 3/8"x66 1/8" (24x60x1678)

Parts Identification

Wood Components

(NOT TO SCALE)



- (6) **J9 - SUPPORT BOARD - W4L06064**
1"x2 3/8"x3" (24x60x76)



- (1) **J10 - SUPPORT BOARD - W4L06194**
1"x2 3/8"x3" (24x60x76)



- (2) **J11 - WALL RAIL - W4L06324**
1"x2 3/8"x44 5/8" (24x60x1135)



- (2) **J12 - SWING RAIL SUPPORT - W4L06342**
1"x2 3/8"x9 1/8" (24x60x232)



- (1) **K1 - GROUND BOARD - W4L06052**
5/8"x5 1/4"x74 1/2" (16x134x1893)

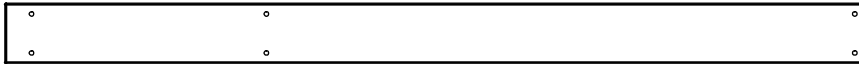

- (1) **K2 - GROUND BOARD - W4L06056**
5/8"x5 1/4"x74 1/2" (16x134x1893)



- (1) **K3 - ARCHED RAIL - W4L06191**
5/8"x5 1/4"x73 1/8" (16x134x1858)

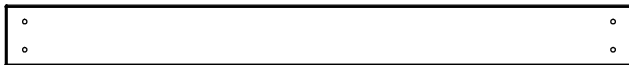

- (1) **K4 - GROUND BOARD - W4L06049**
5/8"x5 1/4"x54 1/2" (16x134x1384)

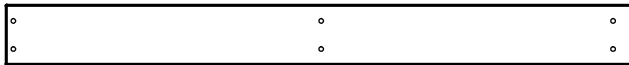

- (1) **K5 - GROUND BOARD - W4L06054**
5/8"x5 1/4"x54 1/2" (16x134x1384)

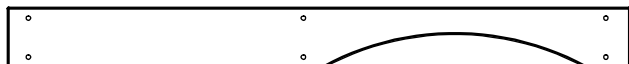

- (1) **K6 - ARCHED RAIL - W4L06084**
5/8"x5 1/4"x54 1/8" (16x134x1374)

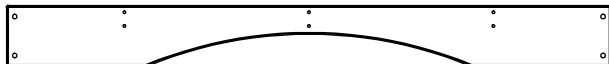

- (1) **K7 - ARCHED RAIL - W4L06105**
5/8"x5 1/4"x52 1/2" (16x134x1334)

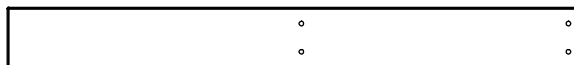

- (1) **K8 - WALL RAIL - W4L06095**
5/8"x5 1/4"x49 1/2" (16x134x1256)

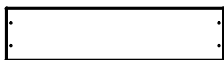

- (8) **K10 - STAIR STEP BOARD - W4L06123**
5/8"x4 5/8"x19" (16x119x483)



- (2) **K11 - HALF MOON PLATE - W4L06115**
5/8"x5 1/4"x12 5/8" (16x134x320)

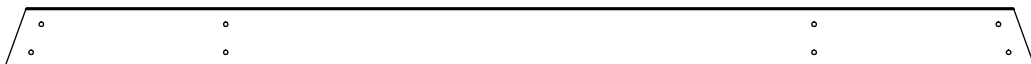

- (1) **K12 - GROUND BOARD - W4L06185**
5/8"x5 1/4"x89 1/2" (16x134x2274)



- (1) **K13 - WALL RAIL - W4L06322**
5/8"x5 1/4"x45" (16x134x1142)

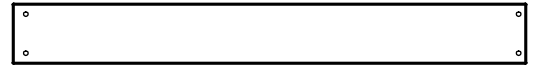

- (1) **K14 - WALL RAIL - W4L06325**
5/8"x5 1/4"x44 5/8" (16x134x1135)

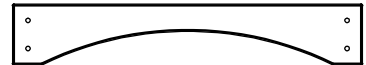

- (1) **K15 - ARCHED RAIL - W4L06326**
5/8"x5 1/4"x30 3/8" (16x134x772)

Parts Identification

Wood Components

(NOT TO SCALE)

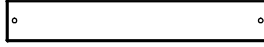

- (1) **L1 - SUPPORT BOARD - W4L06128**
5/8"x3 5/8"x22 3/4" (16x92x579)

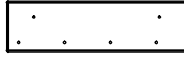

- (1) **L2 - SUPPORT BOARD - W4L06142**
5/8"x4 3/8"x15 5/8" (16x112x397)

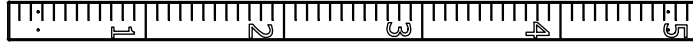

- (1) **M1 - GROWTH BOARD - W4L06143**
5/8"x3 3/8"x60 1/4" (16x86x1530)



- (1) **M2 - WALL BOARD - W4L06097**
5/8"x3 3/8"x61 1/4" (16x86x1557)



- (1) **M3 - WALL BOARD - W4L06099**
5/8"x3 3/8"x61 1/4" (16x86x1557)



- (2) **M4 - WALL BOARD - W4L06109**
5/8"x3 3/8"x61 1/4" (16x86x1557)



- (1) **M5 - WALL BOARD - W4L06111**
5/8"x3 3/8"x61 1/4" (16x86x1557)



- (14) **M6 - FLOOR BOARD - W4L06066**
5/8"x3 3/8"x54 1/2" (16x86x1384)



- (1) **M7 - WALL RAIL - W4L06087**
5/8"x3 3/8"x54 1/2" (16x86x1384)



- (1) **M8 - ARCHED RAIL - W4L06101**
5/8"x3 3/8"x54 1/2" (16x86x1384)

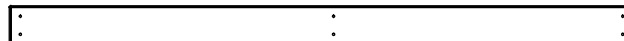

- (2) **M9 - WALL BOARD - W4L06148**
5/8"x3 3/8"x54 1/4" (16x86x1377)



- (1) **M10 - ARCHED RAIL - W4L06103**
5/8"x3 3/8"x53 1/8" (16x86x1350)

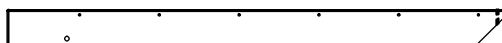

- (4) **M11 - ROOF RAFTER - W4L06114**
5/8"x3 3/8"x43 7/8" (16x86x1114)



- (1) **M12 - ROCK WALL BOARD - W4L06337**
5/8"x2 3/4"x27 3/4" (16x70x704)



- (1) **M13 - WALL RAIL - W4L06112**
5/8"x3 3/8"x29 1/4" (16x86x744)

Parts Identification

Wood Components

(NOT TO SCALE)

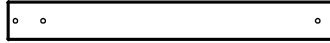

- (1) **M14 - WALL RAIL - W4L06113**
5/8"x3 3/8"x28 5/8" (16x86x728)

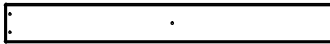

- (17) **M15 - FLOOR BOARD - W4L06120**
5/8"x3 3/8"x29 1/8" (16x86x740)



- (1) **M16 - FLOOR BOARD - W4L06130**
5/8"x3 3/8"x27 3/4" (16x86x704)



- (1) **M17 - WALL RAIL - W4L06094**
5/8"x3 3/8"x27 1/4" (16x86x692)



- (2) **M18 - WALL BOARD - W4L06108**
5/8"x3 3/8"x27" (16x86x686)



- (11) **M19 - WALL BOARD - W4L06096**
5/8"x3 3/8"x27" (16x86x686)



- (1) **M20 - ATTACHMENT BOARD - W4L06146**
5/8"x3 3/8"x21 1/2" (16x86x547)



- (13) **M21 - FLOOR BOARD - W4L06080**
5/8"x3 3/8"x21 1/4" (16x86x540)



- (1) **M22 - FLOOR BOARD - W4L06081**
5/8"x3 3/8"x21 1/4" (16x86x540)



- (24) **M23 - STAIR STEP BOARD - W4L06122**
5/8"x3 1/4"x19" (16x83x483)



- (2) **M24 - WALL RAIL - W4L06107**
5/8"x3 3/8"x15 5/8" (16x86x398)



- (1) **M25 - WALL RAIL - W4L06098**
5/8"x3 3/8"x6 3/4" (16x86x172)



- (1) **M26 - WALL RAIL - W4L06110**
5/8"x3 3/8"x5 3/8" (16x86x138)

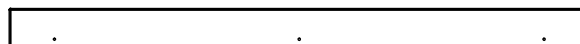

- (2) **M27 - CORNER BOARD - W4L06147**
5/8"x3 3/8"x50 3/8" (16x86x1280)



- (1) **M28 - WALL BOARD - W4L06180**
5/8"x3 3/8"x61 1/4" (16x86x1557)

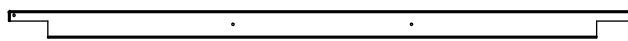

- (2) **N1 - FLOOR BOARD - W4L06067**
5/8"x2 3/8"x54 1/2" (16x60x1384)

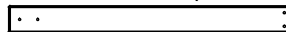

- (2) **N2 - SUNBURST BOARD - W4L06116**
5/8"x2 3/8"x24 3/8" (16x60x620)



- (14) **M29 - WALL BOARD - W4L06181**
5/8"x3 3/8"x28 5/8" (16x86x726)

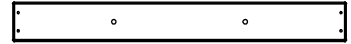

- (1) **M30 - ATTACHMENT BOARD - W4L06338**
5/8"x3 3/8"x29" (16x86x736)



- (1) **M70 - SLIDE BED SUPPORT - W100935**
5/8"x3 3/8"x19 7/8" (16x86x505)



- (9) **M74 - ROCK WALL BOARD - W4L06332**
5/8"x3 3/8"x27 3/4" (16x86x704)



- (4) **M75 - ROCK WALL BOARD - W4L06333**
5/8"x3 3/8"x27 3/4" (16x86x704)



- (4) **M76 - ROCK WALL BOARD - W4L06334**
5/8"x3 3/8"x27 3/4" (16x86x704)



- (1) **M108 - TOP BOARD - W4L06331**
5/8"x3 3/8"x29" (16x86x736)

Parts Identification

Wood Components

(NOT TO SCALE)



- (2) **N3 - FLOOR BOARD - W4L06078**
5/8"x2 3/8"x19 3/4" (16x60x502)



- (8) **N4 - SUNBURST BOARD - W4L06118**
5/8"x2 3/8"x19 5/8" (16x60x500)



- (4) **N6 - SUNBURST BOARD - W4L06117**
5/8"x2 3/8"x15 7/8" (16x60x404)

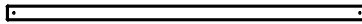

- (22) **O1 - PICKET - W4L06135**
5/8"x1 3/8"x31 1/4" (16x34x795)



- (7) **O2 - SWING SEAT BOARD - W4L06339**
5/8"x1 3/8"x26 5/8" (16x36x676)



- (1) **Q1 - SUPPORT BOARD - W4L06129**
1"x4 3/8"x22 3/4" (24x112x579)



- (1) **SP50 - SWING BEAM SUPPORT - W4L06170**
3 3/8"x3 3/8"x49 3/8" (86x86x1254)



- (1) **T1 - SUPPORT BOARD - W4L06075**
1"x1 3/8"x50" (24x34x1270)



- (2) **T2 - SUPPORT BOARD - W4L06065**
1"x1 3/8"x49 5/8" (24x34x1260)



- (1) **T3 - PICKET - W4L06136**
1"x1 3/8"x27 1/8" (24x34x688)



- (1) **T4 - SUPPORT BOARD - W4L06077**
1"x1 3/8"x23 7/8" (24x34x606)



- (1) **T5 - SUPPORT BOARD - W4L06076**
1"x1 3/8"x21 1/2" (24x34x546)



- (1) **T6 - PICKET - W4L06137**
1"x1 3/8"x19 5/8" (24x34x500)



- (1) **T7 - PICKET - W4L06138**
1"x1 3/8"x18 3/8" (24x34x468)



- (2) **T8 - SUPPORT BOARD - W4L06119**
1"x1 3/8"x16 5/8" (24x34x423)



- (1) **T9 - PICKET - W4L06139**
1"x1 3/8"x15 1/4" (24x34x386)



- (1) **N5 - FLOOR BOARD - W4L06328**
5/8"x2 3/8"x26 1/4" (16x60x668)



- (1) **N7 - SWING BACK SUPPORT - W4L06349**
5/8"x2 3/8"x26 5/8" (16x60x676)



- (1) **N8 - SWING SEAT SUPPORT - W4L06350**
5/8"x2 3/8"x24 3/4" (16x60x628)



- (7) **O3 - SWING SEAT BOARD - W4L06340**
5/8"x1 3/8"x28 1/2" (16x36x724)

Parts Identification

Wood Components

(NOT TO SCALE)



- (1) **T10 - PICKET - W4L06140**
1"x1 3/8"x12" (24x34x304)



- (1) **T11 - PICKET - W4L06141**
1"x1 3/8"x8 3/4" (24x34x222)



- (2) **T12 - SUPPORT BOARD - W4L06329**
1"x1 3/8"x40 1/2" (24x34x1029)



- (1) **E12 - UPRIGHT - W2A01864**
1 3/8"x3 3/8"x57 3/8" (36x86x1457)



- (2) **RP1 - ROOF PANEL - W2A01860**
1 3/8"x12 1/4"x59 1/2" (35x311x1532)

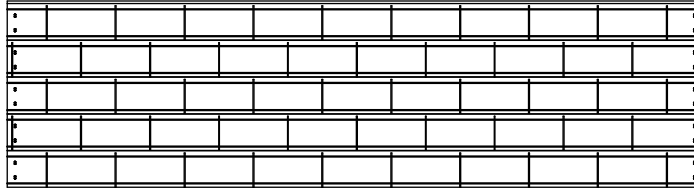

- (2) **RP2 - ROOF PANEL - W2A01861**
1 3/8"x16 1/8"x59 1/2" (35x410x1532)

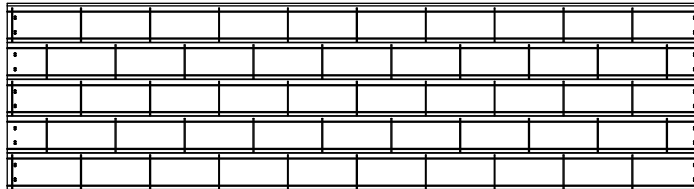

- (2) **RP3 - ROOF PANEL - W2A01862**
1 3/8"x16 1/8"x59 1/2" (35x410x1532)

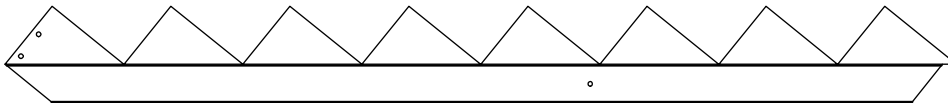

- (1) **SR1 - STAIR RAIL - W2A01863**
1"x8 3/8"x82 5/8" (24x214x2099)

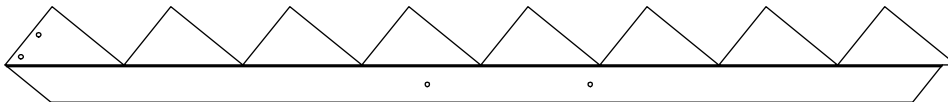

- (1) **SR2 - STAIR RAIL - W2A01868**
1"x8 3/8"x82 5/8" (24x214x2099)

Parts Identification

Hardware



(1) - BOLT WH 5/16x6 BLK - H100363

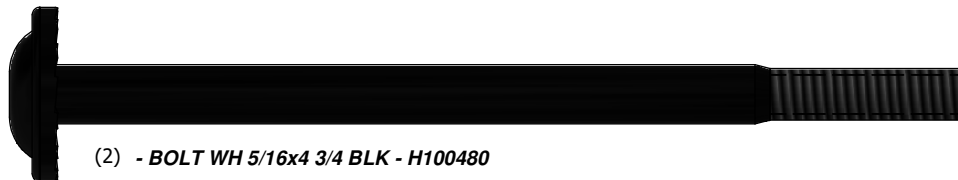

(2) - BOLT WH 5/16x4 3/4 BLK - H100480

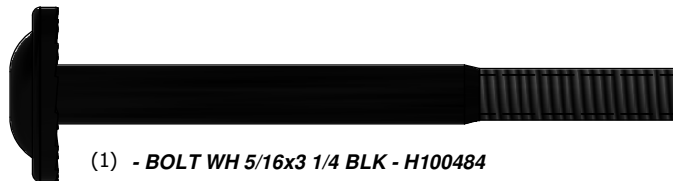

(1) - BOLT WH 5/16x3 1/4 BLK - H100484

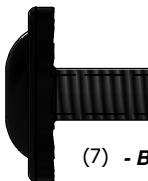

(7) - BOLT WH 5/16x1/2 BLK - H100396



(6) - BOLT WH 5/16x3 BLK - H100416

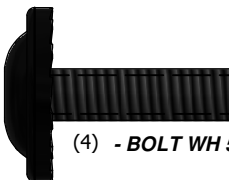

(4) - BOLT WH 5/16x1 BLK - H100468



(2) - BOLT WH 5/16x2-3/4 BLK - H100195

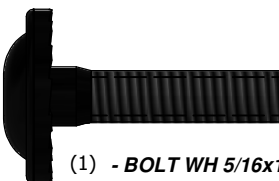

(1) - BOLT WH 5/16x1 1/4 BLK - H100459



(67) - BOLT WH 5/16x2-1/4 BLK - H100205



(43) - LAG SCREW WH 5/16x1-1/2 BLK - H100471

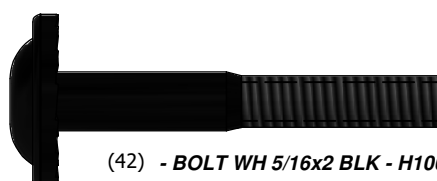

(42) - BOLT WH 5/16x2 BLK - H100457



(28) - LAG SCREW WH 5/16x2 BLK - H100458

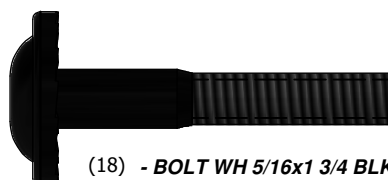

(18) - BOLT WH 5/16x1 3/4 BLK - H100378



(4) - LAG SCREW WH 5/16x3 BLK - H100206



(29) - BOLT WH 5/16x1 1/2 BLK - H100407

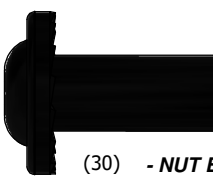

(30) - NUT BARREL WH 5/16x7/8 BLK - H100192

Parts Identification

Hardware

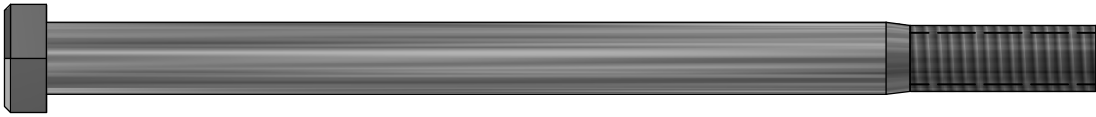

(13) - BOLT HEX 3/8x5-1/2 - H100654



(2) - BOLT HEX 5/16x4 1/4 BLK - H100476

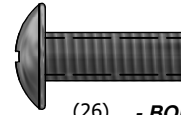

(26) - BOLT PTH 1/4x3/4 - H100063



(7) - BOLT HEX 5/16x1-1/2 - BLK - H100498



(4) - LAG SCREW WH 1/4x2 BLK - H100487



(4) - BOLT HEX 5/16x1 1/4 BLK - H100481



(21) - LAG SCREW WH 1/4x1-1/2 BLK - H100403



(13) - SCREW PFH 8x3 - H100092



(2) - BOLT WH 1/4x1 1/2 BLK - H100406

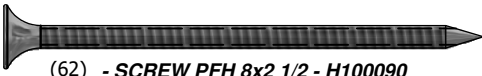

(62) - SCREW PFH 8x2 1/2 - H100090

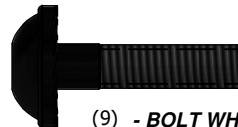

(9) - BOLT WH 1/4x1 BLK - H100171



(11) - SCREW PFH 8x2 - H100111



(87) - SCREW PFH 8x1-3/4" - H100089

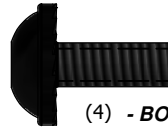

(4) - BOLT WH 1/4x5/8 BLK - H100486



(348) - SCREW PFH 8x1-1/2" - H100086



(176) - SCREW PFH 8x1-1/4" - H100087

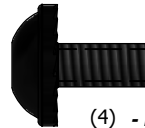

(4) - BOLT WH 1/4x1/2 BLK - H100401

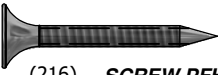

(216) - SCREW PFH 8x1-1/8" - H100088



(4) - NUT BARREL WH 1/4x7/8 BLK - H100399



(11) - NUT BARREL WH 1/4x5/8 BLK - H100404



(4) - SCREW PFH 8x3/4 - H100121



(2) - SCREW PWH 8x5/8 - H100128

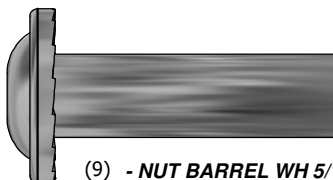

(9) - NUT BARREL WH 5/16x1 1/2 - H100006

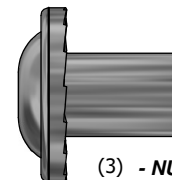

(3) - NUT BARREL WH 5/16x5/8 - H100004



(4) - SCREW PWH 8x1/2 BLK - H100408

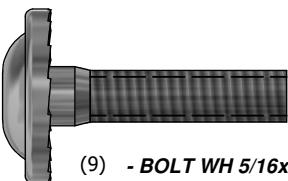

(9) - BOLT WH 5/16x1 1/4 - H100009

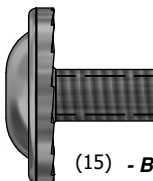

(15) - BOLT WH 5/16x1/2 - H100115

Parts Identification

Hardware

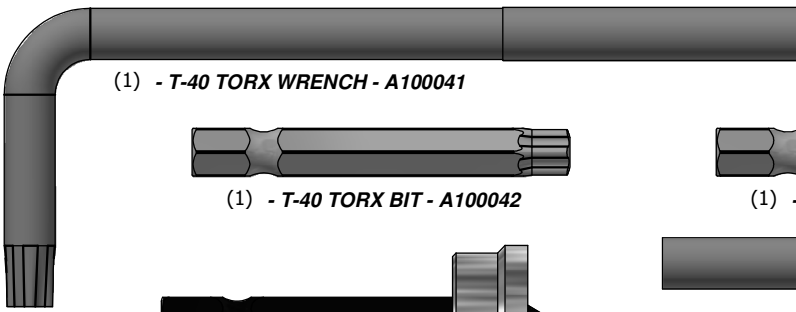

(1) - T-40 TORX WRENCH - A100041



(1) - T-40 TORX BIT - A100042



(1) - T-30 TORX BIT - H100147



(1) - SCREW SETTER - H100764



(1) - T-30 TORX WRENCH - H100114

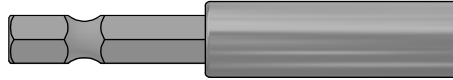

(1) - MAGNETIC DRIVER - H101100

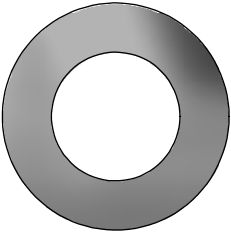

(2) - WASHER SAFETY 17x30 - H100103



(9) - WASHER FLAT 8x27 BLK - H100478

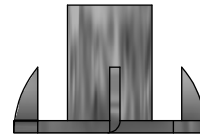

(13) - T-NUT 3/8 - H100073

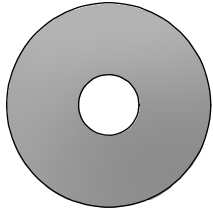

(2) - WASHER FLAT 8x27 - H100105



(25) - WASHER LOCK EXT 12x19 BLK - H100199

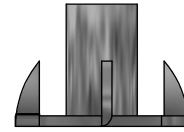

(3) - T-NUT 5/16 - H100074

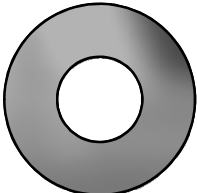

(13) - WASHER FLAT 11x25 - H100102

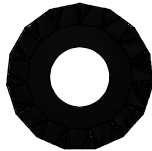

(224) - WASHER LOCK EXT 8x19 BLK - H100198



(148) - T-NUT 5/16 BLK - H100379

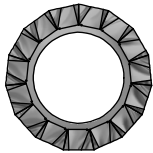

(3) - WASHER LOCK EXT 12x19 - H100031



(24) - WASHER FLAT 9x18 BLK - H100474

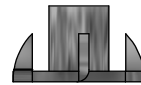

(26) - T-NUT 1/4 - H100072

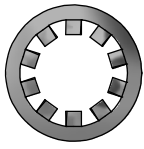

(13) - WASHER LOCK INT 10x18 - H100107



(15) - WASHER LOCK EXT 8x15 BLK - H100400



(4) - T-NUT 1/4 BLK - H100398

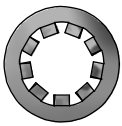

(26) - WASHER LOCK INT 8x15 - H100108



(14) - WASHER LOCK EXT 6x15 BLK - H100405

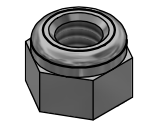

(2) - NUT LOCK 5/16 - H100110



(7) - WASHER SPLIT 5/16 BLK - H100477



(9) - NUT LOCK 5/16 BLK - H100479

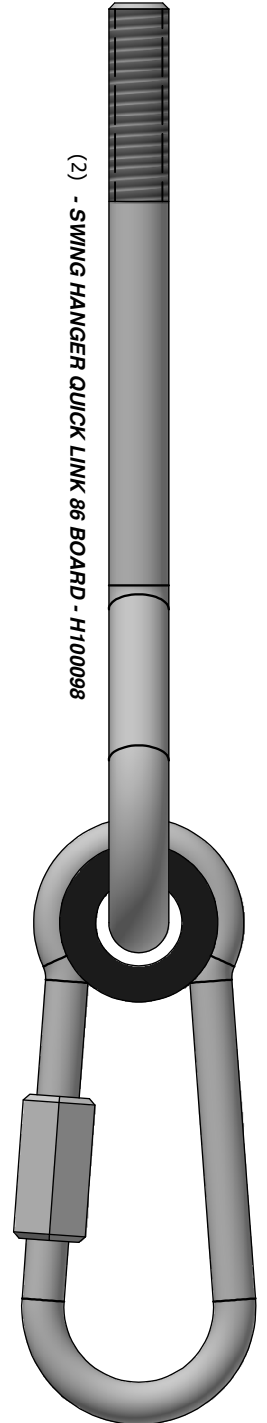

(2) - SWING HANGER QUICK LINK 86 BOARD - H100098

Parts Identification

Accessories (NOT TO SCALE)

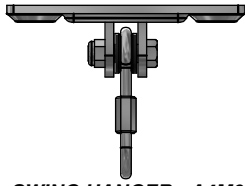

(6) - SWING HANGER - A4M00505



(1) - "A" REVISION TAG - A100314



(10) - QUICK LINK - A100069



(2) - SWING SEAT GREEN 22" - A6P00054



(4) - SLIDE TUBE SUPPORT - A6P00487



(2) - METAL DECK BRACE 380 C/C - A4M00630



(1) - PLASTIC CURTAIN ROD - A6P00090

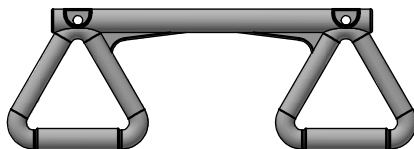

(1) - TRAPEZE YELLOW - A6P00034

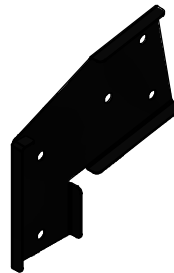

(1) - SWING BEAM EXTENSION BRACKET-LEFT - A4M00617

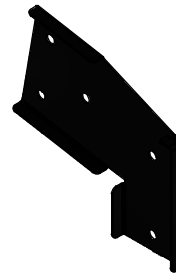

(1) - SWING BEAM EXTENSION BRACKET-RIGHT - A4M00618



(5) - METAL RUNG 547 - A4M00616



(4) - HAND GRIP METAL BLACK 381 c/c - A4M00613



(1) - BYD ID TAG (LARGE) AGES 3-10 - A100164



(15) - METAL TUBE - A4M00620



(10) - AUGER GROUND STAKE - A100178



(47) - METAL TUBE - A4M00597



(6) - 90° L-BRACKET - BLK - A4M00555



(2) - L BRACKET BLK - A4M00615
2.5x38x50x55



(2) - L BRACKET 66x66x127 - BLK - A4M00619



(2) - CHAIN GREEN 31" - A100177



(4) EF - CHAIN GREEN 57" - A100047

Parts Identification

Accessories (NOT TO SCALE)

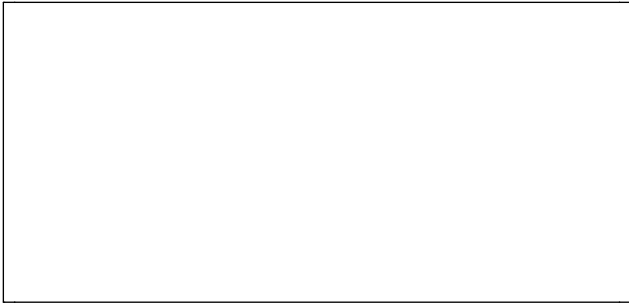

(1) - HAMMOCK - A6P00066



(2) - CURTAIN - A6P00089



(2) - CHAIN SUPPORT BRACKET BLK - A4M00632



(2) - TIE STRAP PLATE BLK - A4M00631



(1) - SLIDE BED 10' LIGHT GREEN - A100035



(2) - CHAIN - A4M00638

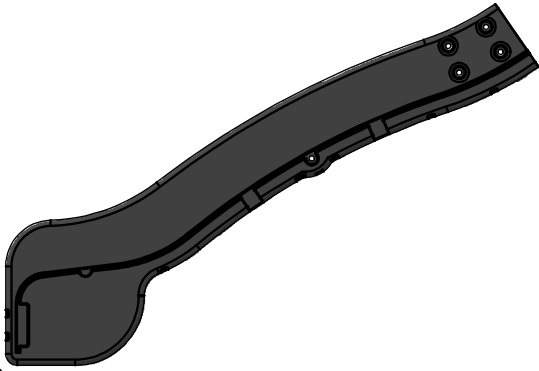

(1) 483 - SLIDE RAIL 10' BOTTOM LEFT GREEN - A6P00483

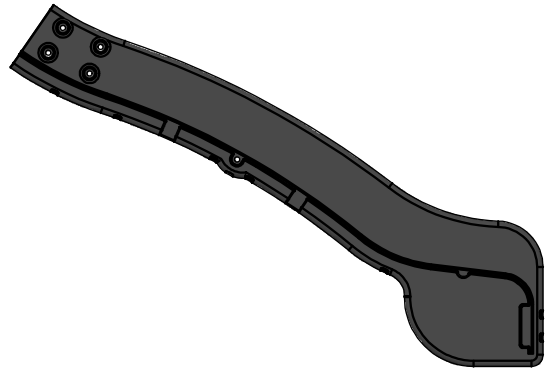

(1) 484 - SLIDE RAIL 10' BOTTOM RIGHT GREEN - A6P00484

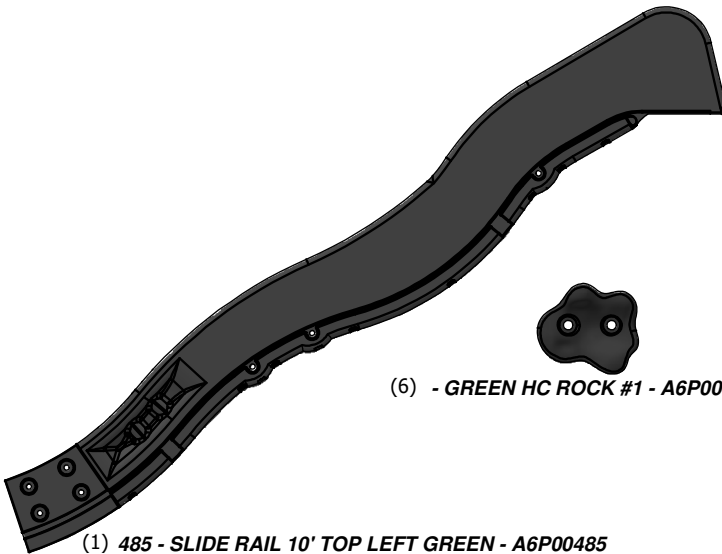

(1) 485 - SLIDE RAIL 10' TOP LEFT GREEN - A6P00485

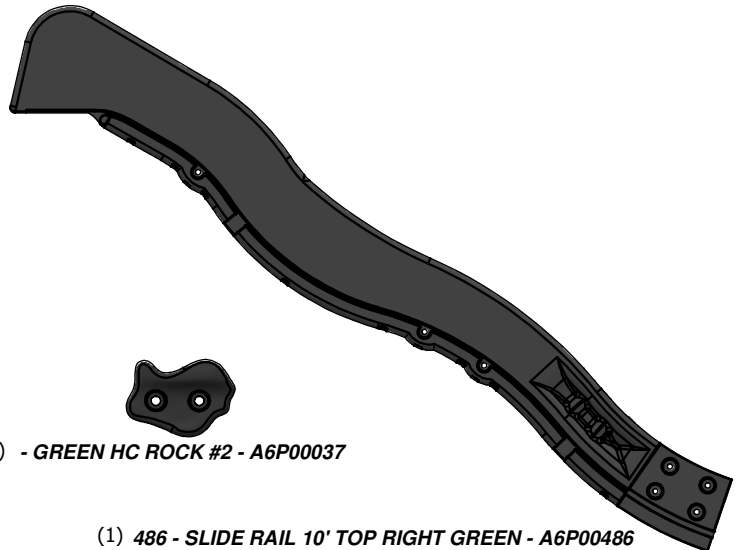

(1) 486 - SLIDE RAIL 10' TOP RIGHT GREEN - A6P00486



(6) - GREEN HC ROCK #1 - A6P00036



(6) - GREEN HC ROCK #2 - A6P00037

PRE-ASSEMBLY STEP 1 - SORTING PARTS

It is critical for ease of assembly that you take the time to sort and organize the wood and hardware.

WOOD PARTS:

- Organize wood parts by the three-digit, alpha-numeric number stamped on each board (ex. P01).
- If there are multiple boards with the same stamped number, stack those pieces together.
- Stamps can be found on the flat surface of the boards or on the end of the boards.
- Allow yourself plenty of room - the wood pieces can take up a significant amount of space.

NOTE: CARTONS ARE NOT ORGANIZED BY BOARD NUMBER.

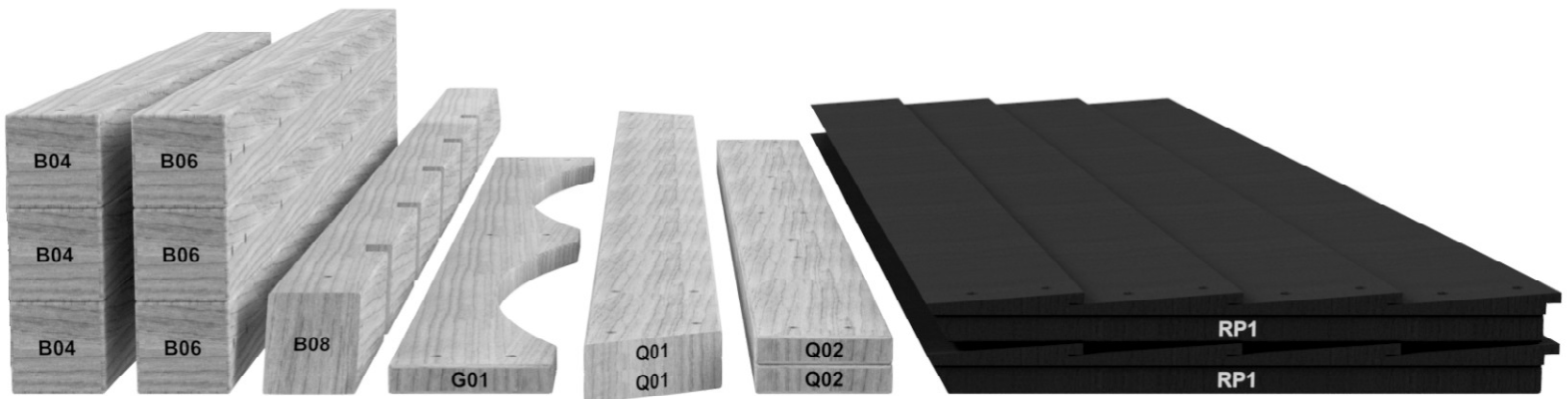

HARDWARE PARTS:

- We recommend that you have a separate table to organize the hardware.
- Hardware bags are printed with a seven-digit, alpha-numeric part number.
- You can organize your hardware by part number or group by hardware type (i.e. bolts, nuts, etc.).
- During assembly you only need to reference the last four digits of the number.

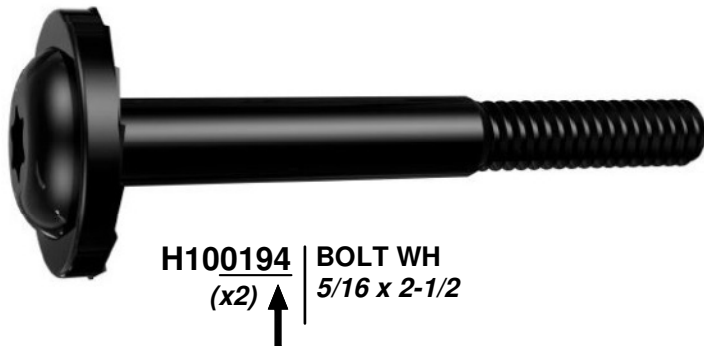

PRE-ASSEMBLY STEP 2 - TOOLS REQUIRED



**Cordless Drill or
Electric Drill**



**Drill Attachments:
Phillips Head**



**1/8", 3/16", 3/8" & 7/16"
Drill Bits**



Phillips Screw Driver



Open End Wrenches 1/2" & 9/16"



**3/8" Drive Ratchet, 1/2" &
9/16" STD Sockets 1/2" & 9/16" Deep
Sockets**



Claw Hammer



Rubber Mallet - Optional



Tape Measure

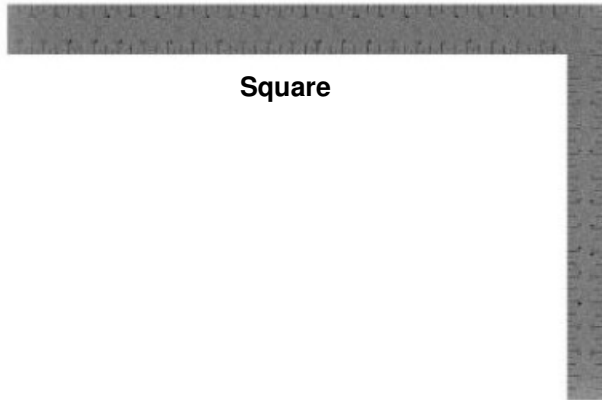

Square



Level 24"

PRE-ASSEMBLY STEP 3 - CHOOSE YOUR ASSEMBLY METHOD

There are several types of assembly instructions available to you.

1. **Printed Assembly Manual** included with your set
2. **BILT APP** - 3D interactive instructions
3. **Combination of the Printed Manual and BILT APP** (Note: Step numbers can differ between the two methods)

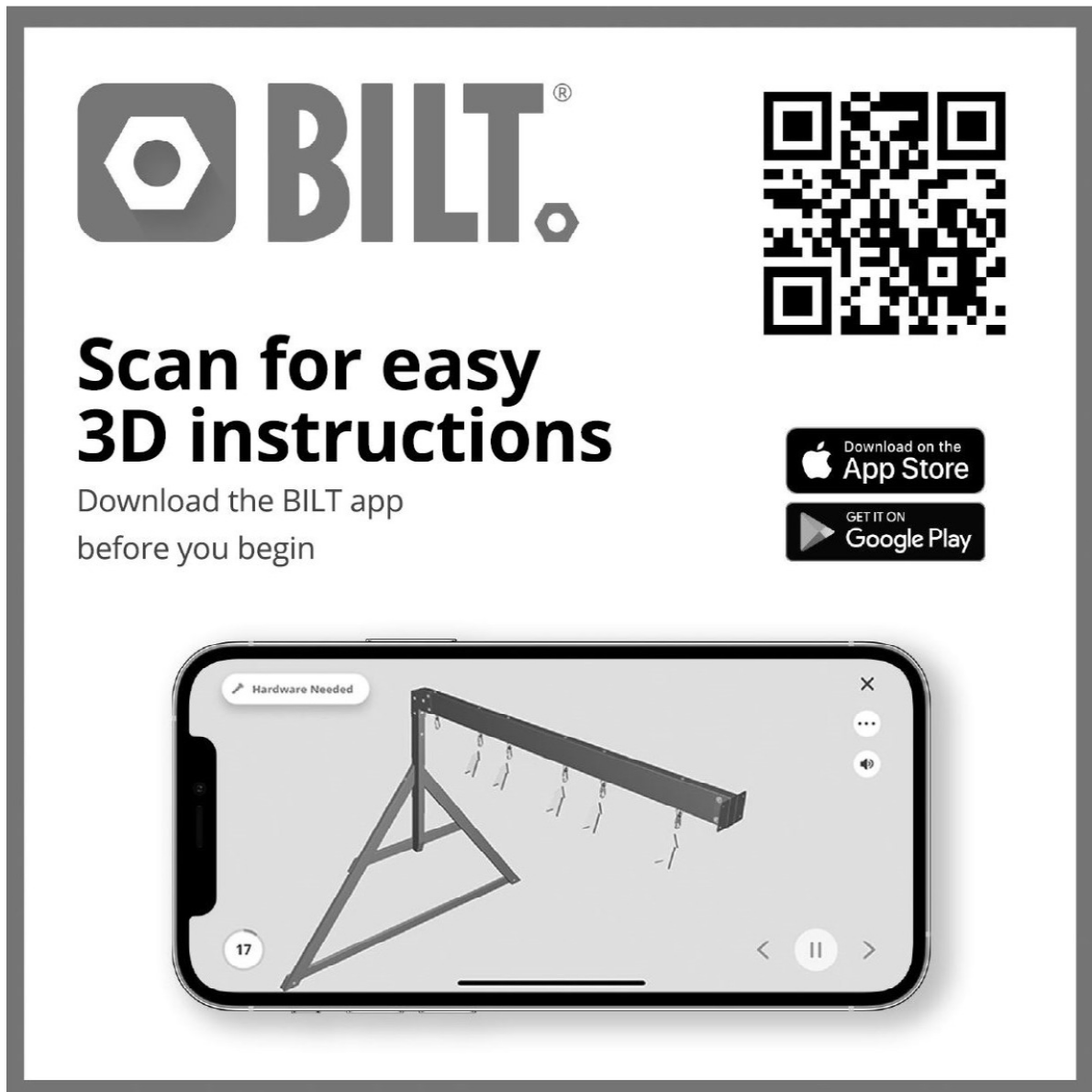

The advertisement features the BILT logo (a hexagon with a dot) and the word "BILT." in a large, bold, sans-serif font. To the right is a large QR code. Below the logo, the text "Scan for easy 3D instructions" is written in a large, bold font, followed by "Download the BILT app before you begin" in a smaller font. To the right of this text are two buttons: "Download on the App Store" and "GET IT ON Google Play". At the bottom, a smartphone screen displays a 3D assembly instruction for step 17, showing a metal frame with a horizontal bar and several hanging components. The screen includes a "Hardware Needed" label, a close button (X), a menu button (three dots), a volume icon, and navigation arrows.

(1) **M30 - ATTACHMENT BOARD - W4L06338**
 5/8"x3 3/8"x29" (16x86x736)

(1) **E72 - LEFT RAIL - W4L06335**
 1 3/8"x3 3/8"x61 1/8" (36x86x1553)

(1) **E73 - RIGHT RAIL - W4L06336**
 1 3/8"x3 3/8"x61 1/8" (36x86x1553)

(1) **M12 - ROCK WALL BOARD - W4L06337**
 5/8"x2 3/4"x27 3/4" (16x70x704)

(9) **M74 - ROCK WALL BOARD - W4L06332**
 5/8"x3 3/8"x27 3/4" (16x86x704)

(4) **M76 - ROCK WALL BOARD - W4L06334**
 5/8"x3 3/8"x27 3/4" (16x86x704)

(4) **M75 - ROCK WALL BOARD - W4L06333**
 5/8"x3 3/8"x27 3/4" (16x86x704)

ROCKWALL ASSEMBLY STEP 1

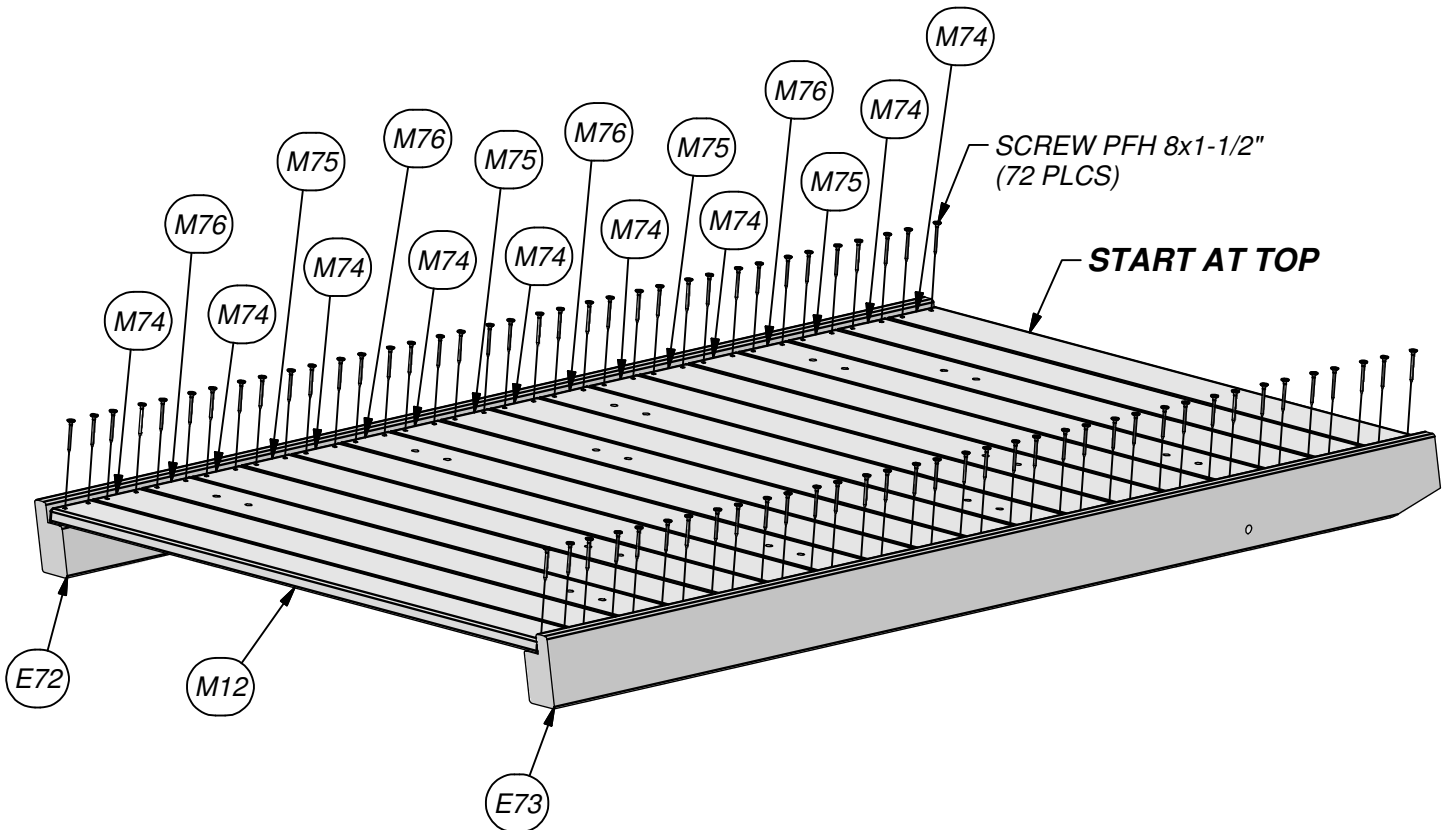
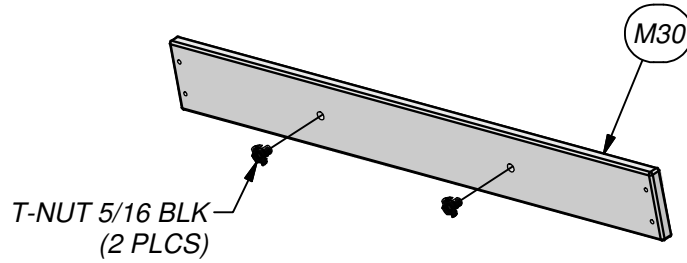
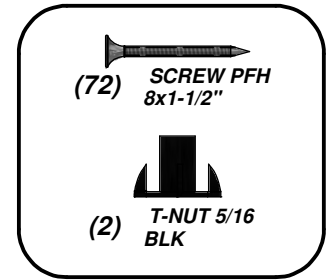

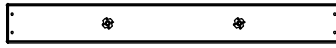

BOARD WITH T-NUTS



(1) M108 - TOP BOARD - W4L06331
5/8"x3 3/8"x29" (16x86x736)

**ROCKWALL ASSEMBLY
STEP 2**

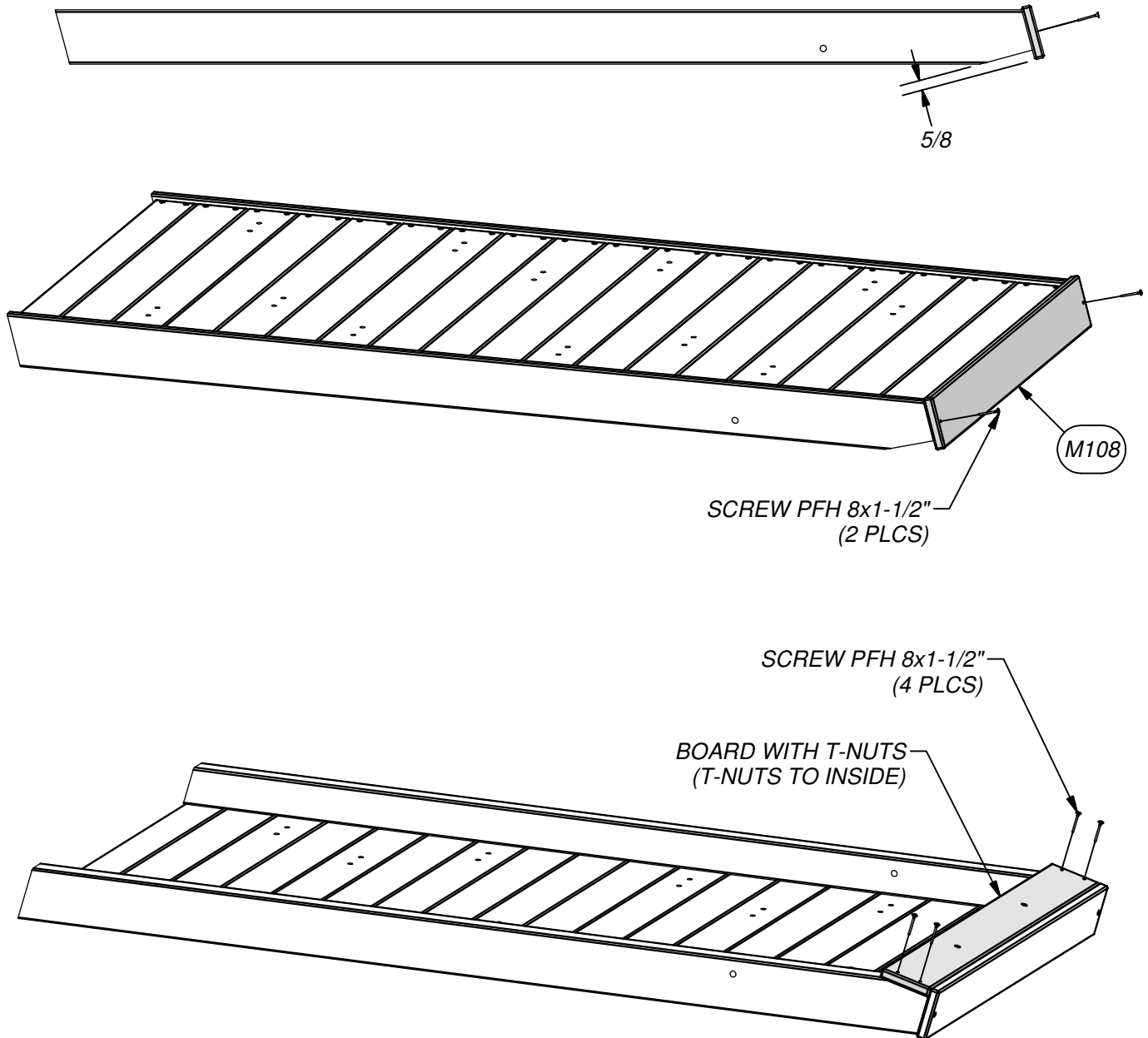
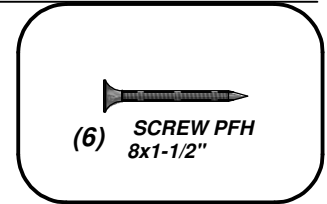





(6) - GREEN HC ROCK #1 - A6P00036



(6) - GREEN HC ROCK #2 - A6P00037

ROCKWALL ASSEMBLY STEP 3

	(24)		(24)
WASHER LOCK INT 8x15		BOLT PTH 1/4x3/4	
			(24)
		T-NUT 1/4	

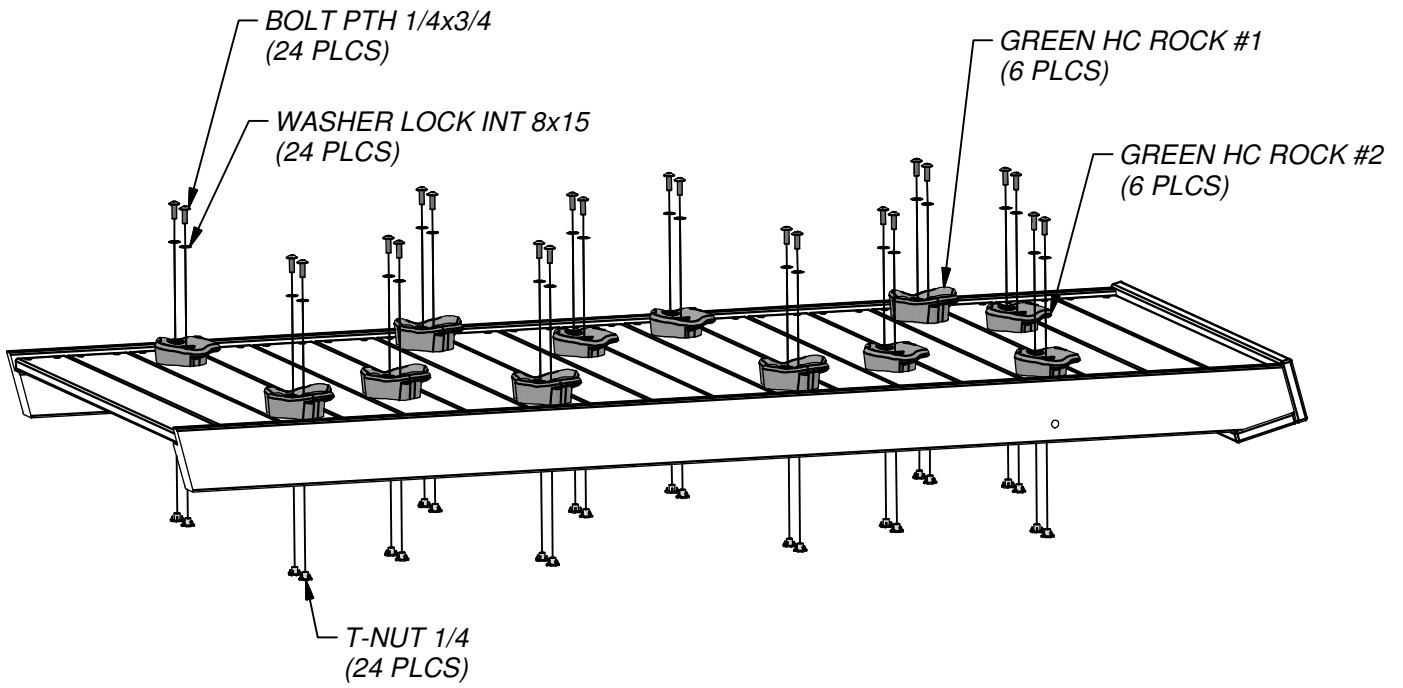

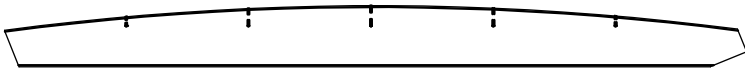

(2) G2 - LADDER UPRIGHT - W4L06144
1"x5 1/4"x64 1/2" (24x134x1637)





(1) M20 - ATTACHMENT BOARD - W4L06146
5/8"x3 3/8"x21 1/2" (16x86x547)

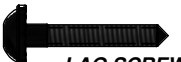

(5) - METAL RUNG 547 - A4M00616

LADDER ASSEMBLY

(10) LAG SCREW
WH 1/4x1-1/2
BLK

(4) SCREW PFH
8x1-1/2"

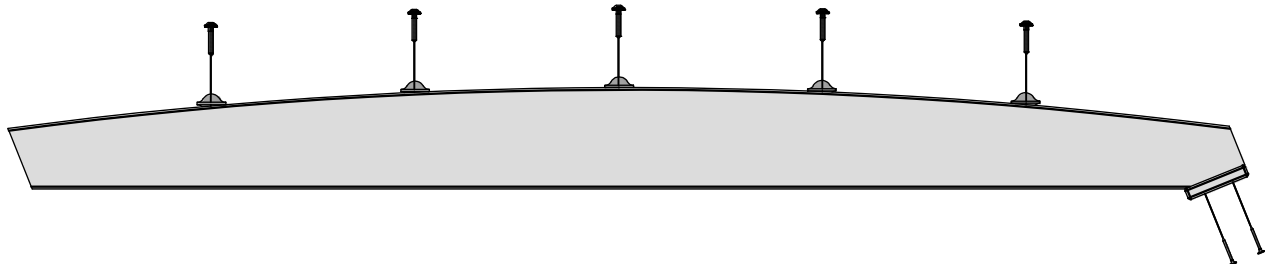
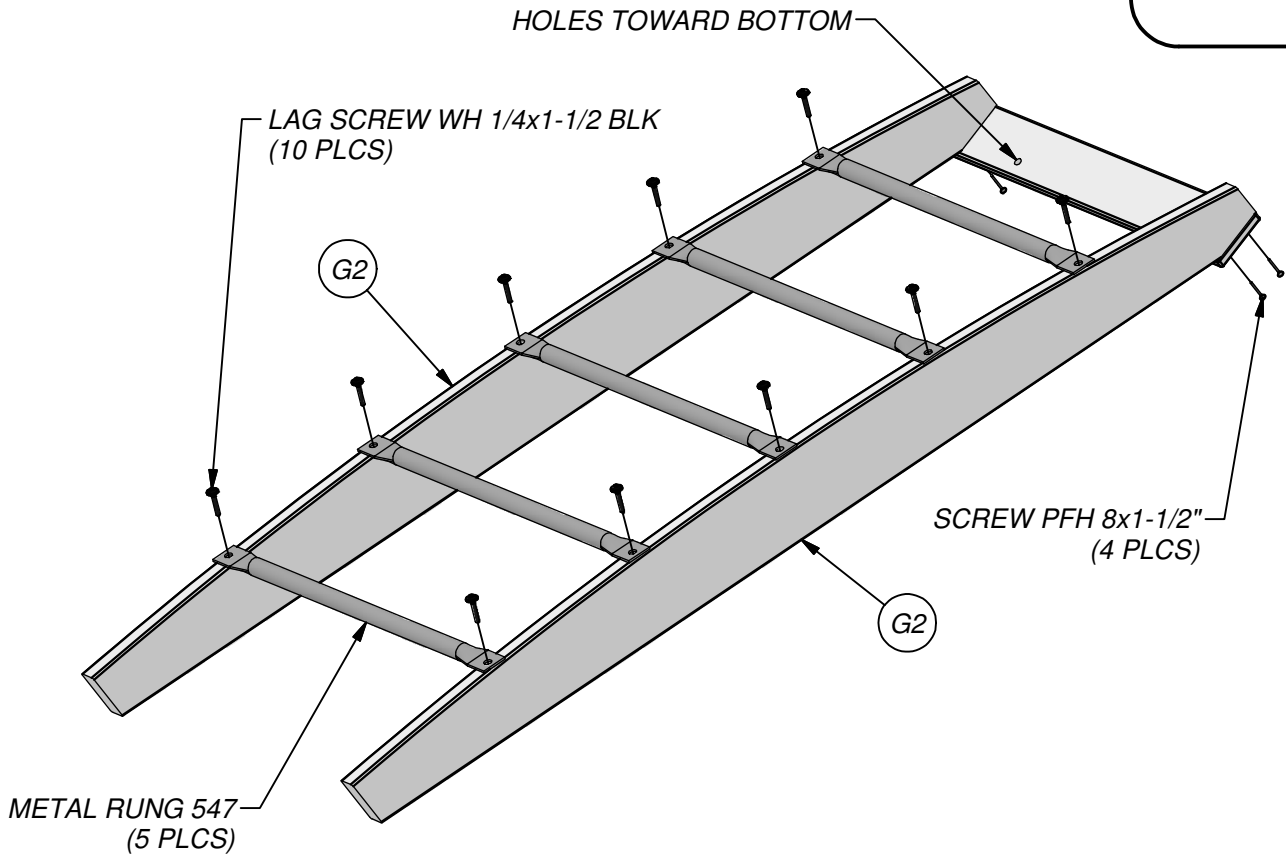

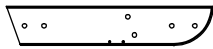

(2) **H17 - SIDE BACK RAIL - W4L06343**
1"x3 3/8"x18" (24x86x456)



(1) **H20 - CENTER BACK RAIL - W4L06346**
1"x3 3/8"x18" (24x86x456)

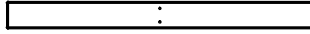

(1) **N7 - SWING BACK SUPPORT - W4L06349**
5/8"x2 3/8"x26 5/8" (16x60x676)



(2) - **TIE STRAP PLATE BLK - A4M00631**

SWING ASSEMBLY STEP 1

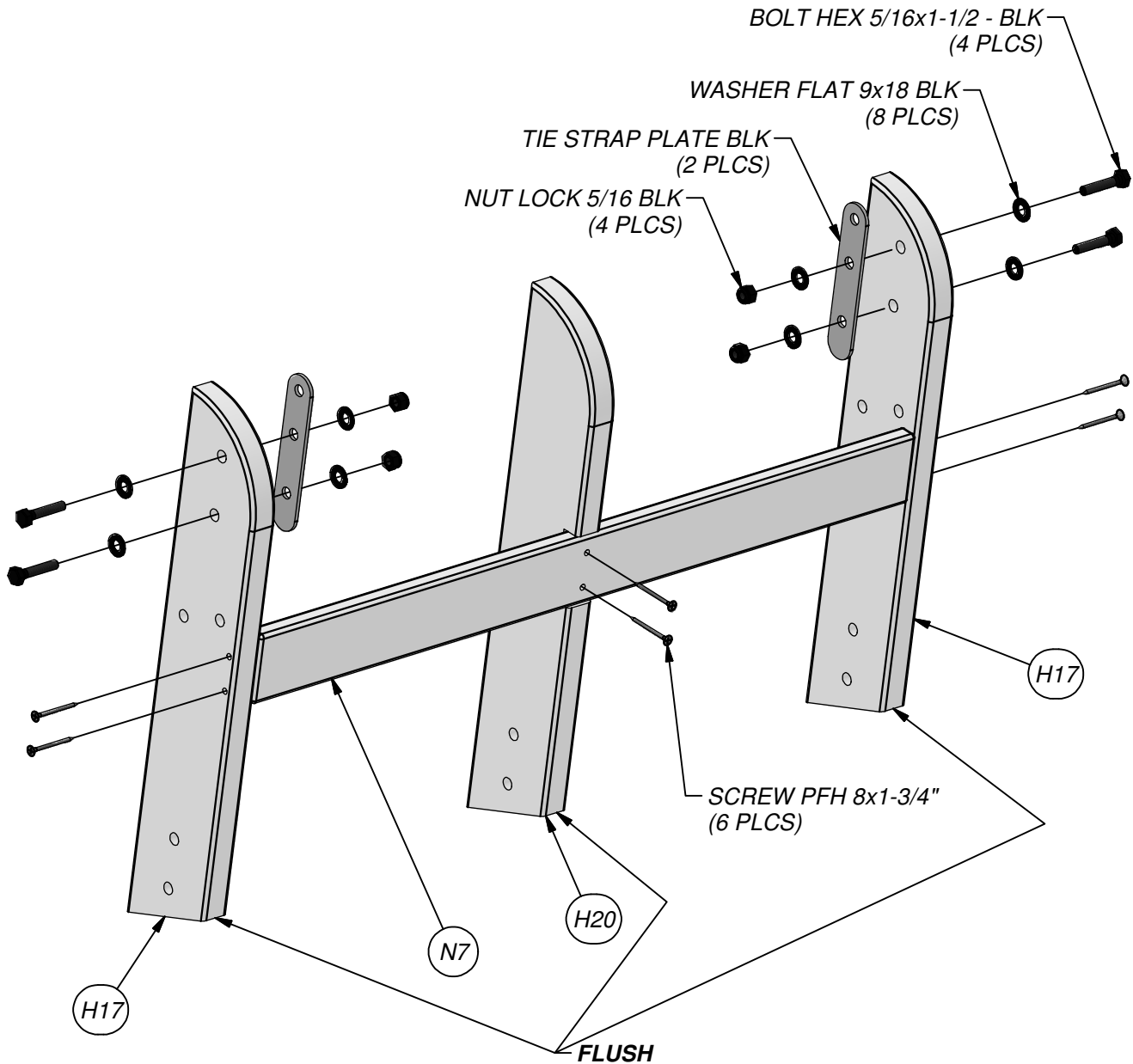
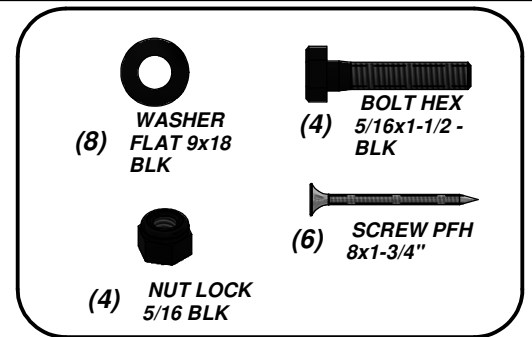

(2) **H18 - SIDE SEAT SUPPORT - W4L06344**
 1"x3 3/8"x16 1/8" (24x86x410)

(1) **H19 - CENTER SEAT SUPPORT - W4L06345**
 1"x3 3/8"x16 1/8" (24x86x410)

(1) **N8 - SWING SEAT SUPPORT - W4L06350**
 5/8"x2 3/8"x24 3/4" (16x60x628)

SWING ASSEMBLY
STEP 2

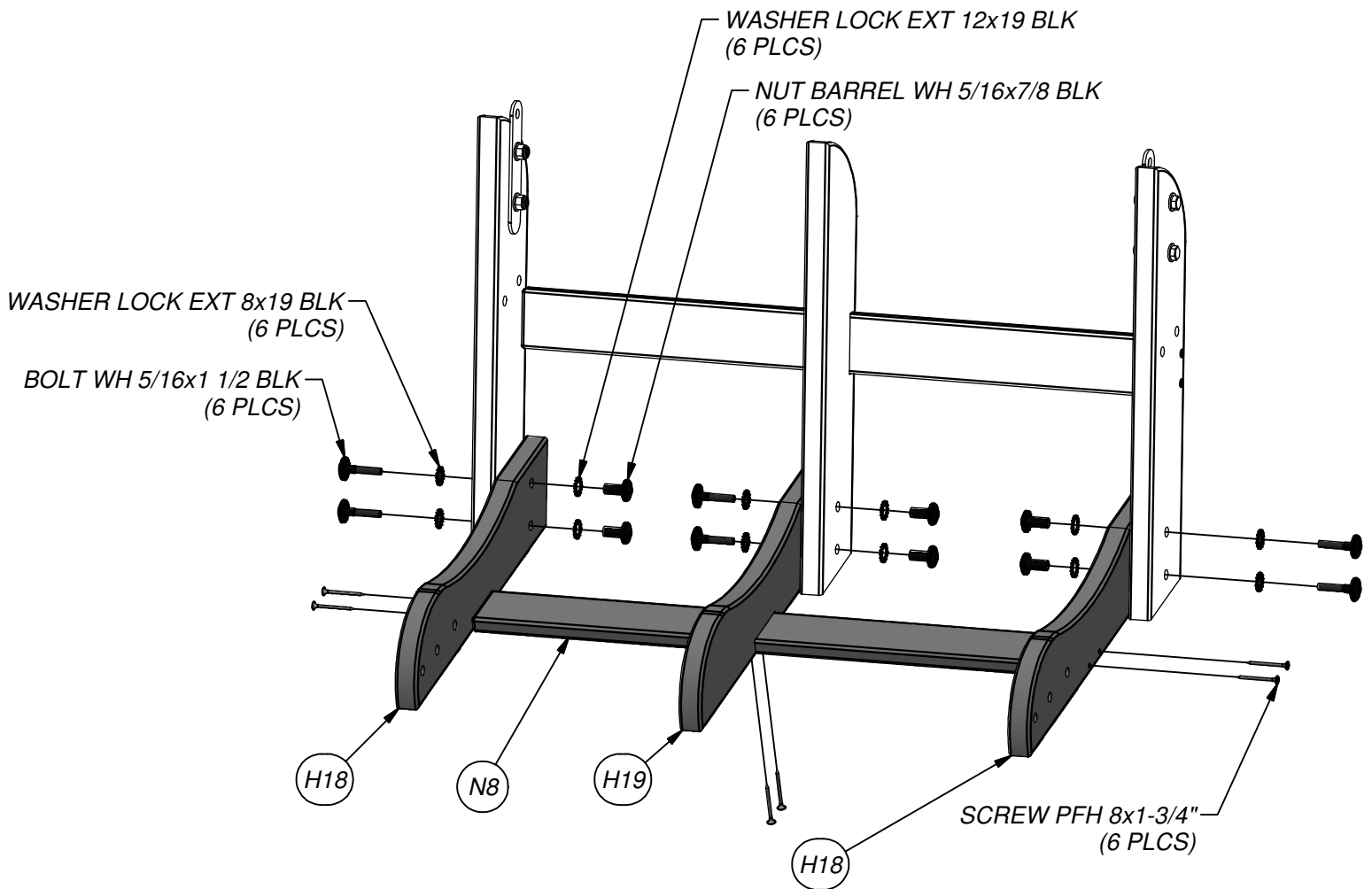
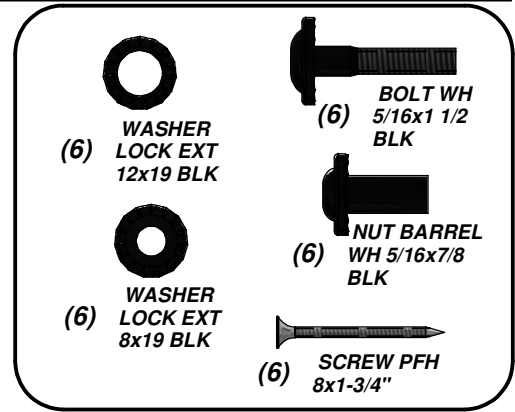

O2 - SWING SEAT BOARD - W4L06339
(7) 5/8"x1 3/8"x26 5/8" (16x36x676)

SWING ASSEMBLY
STEP 3

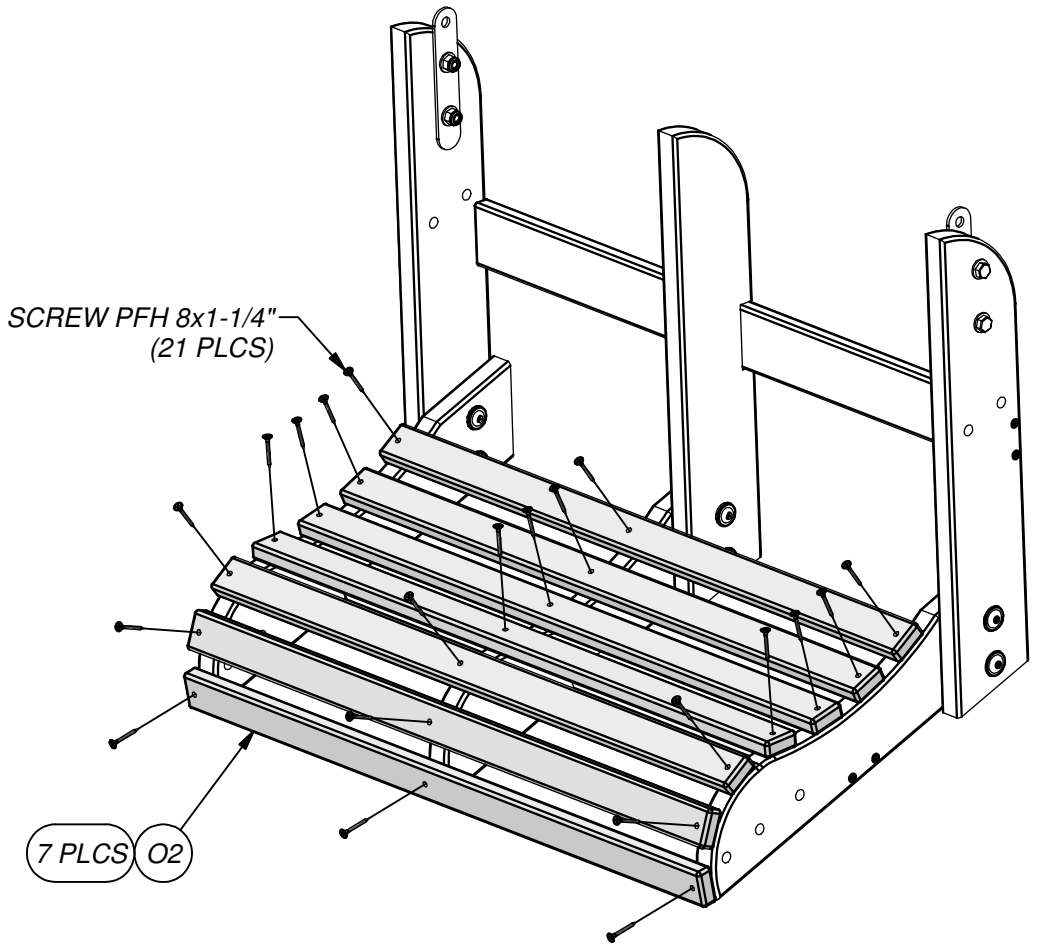
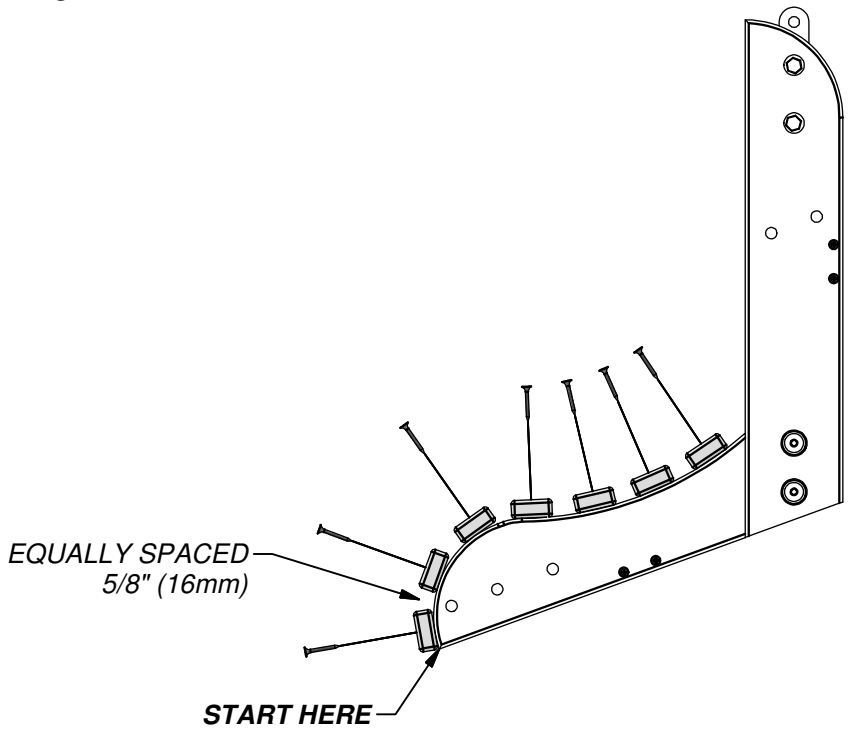
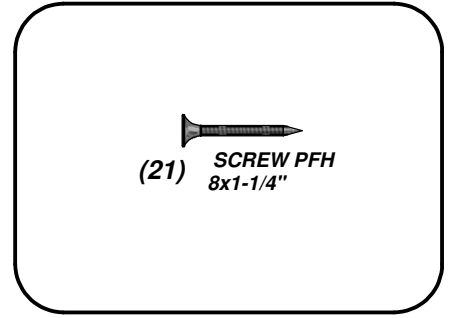

O3 - SWING SEAT BOARD - W4L06340
(7) 5/8"x1 3/8"x28 1/2" (16x36x724)

**SWING ASSEMBLY
STEP 4**

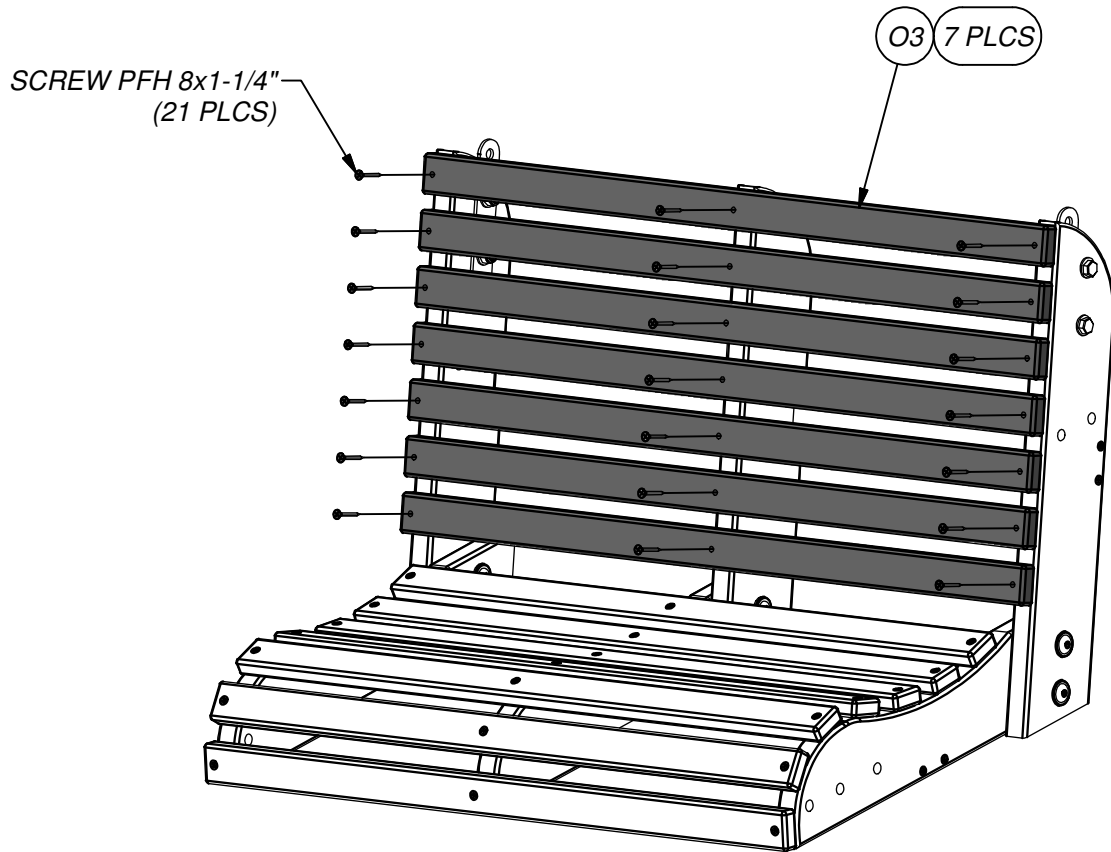
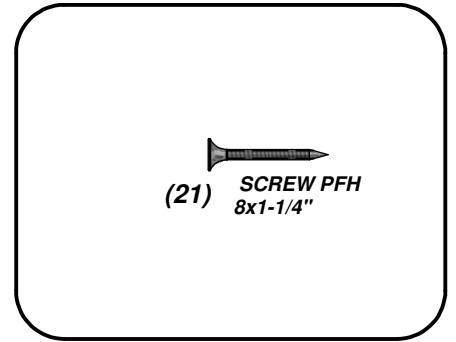
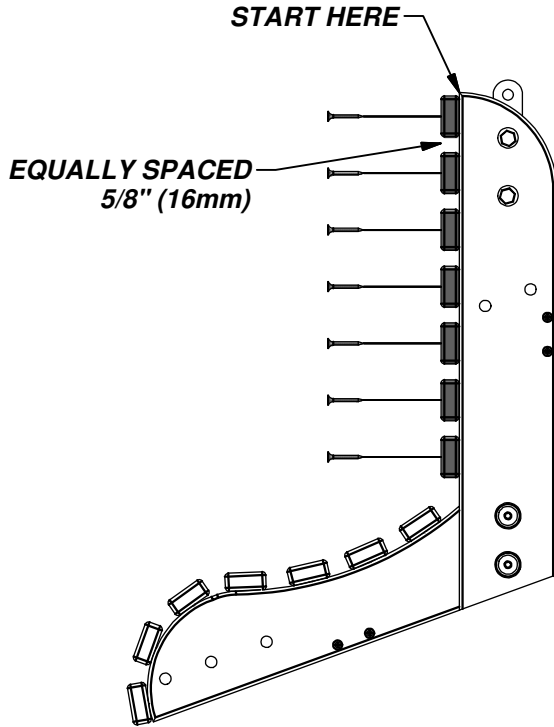



(2) **H16 - SWING RAIL SUPPORT - W4L06341**
 1"x3 3/8"x9 1/8" (24x86x232)



(2) - **CHAIN SUPPORT BRACKET BLK - A4M00632**

SWING ASSEMBLY
STEP 5

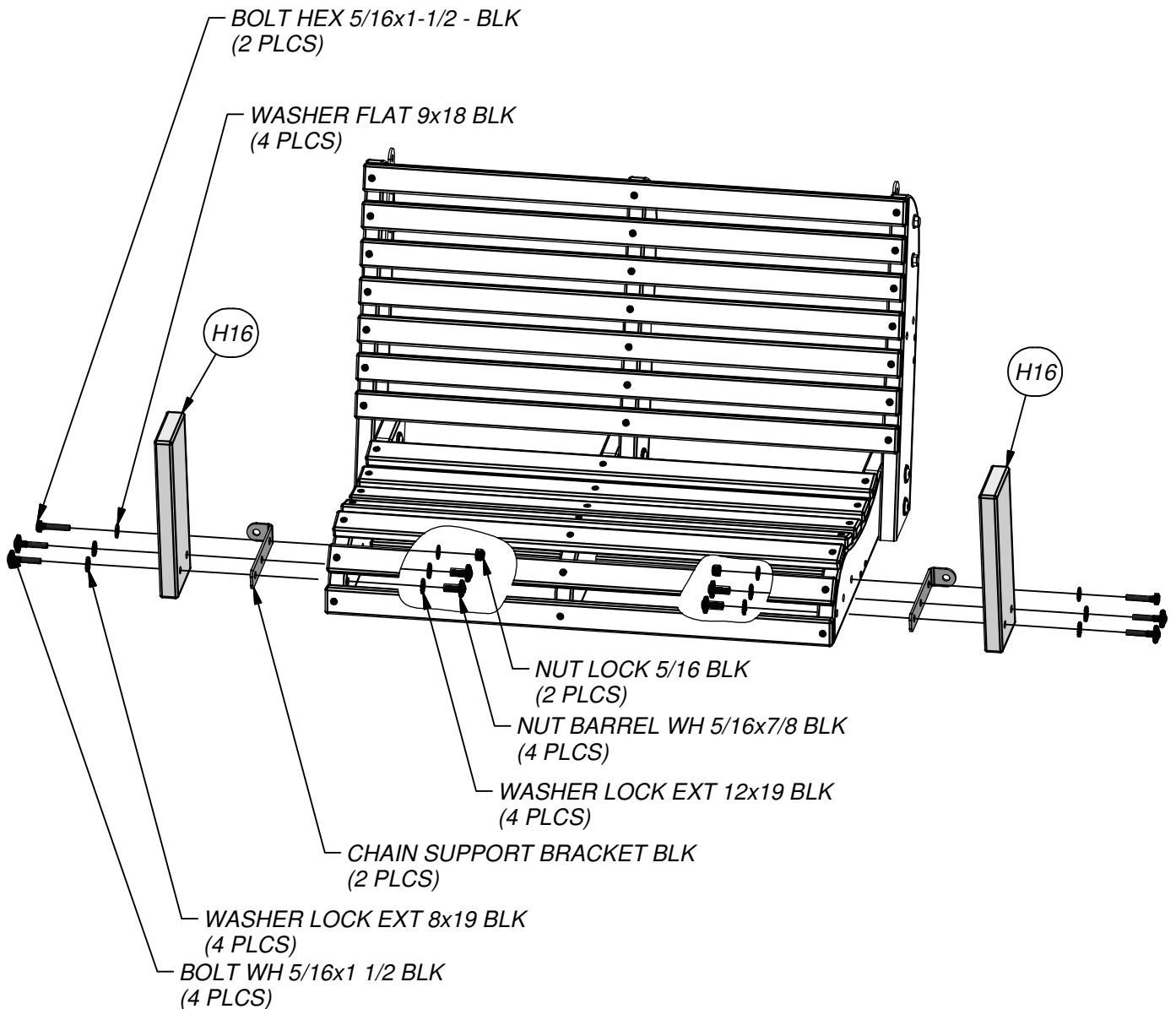
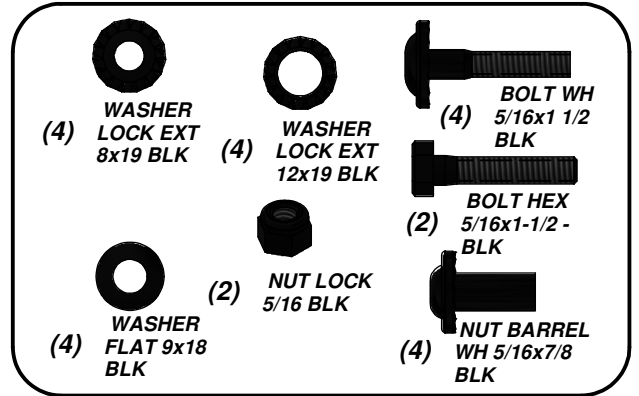

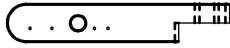

(1) H21 - LEFT ARM REST - W4L06347
1"x3 3/8"x19 3/8" (24x86x492)

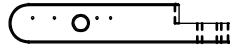

(1) H24 - RIGHT ARM REST - W4L06348
1"x3 3/8"x19 3/8" (24x86x492)

SWING ASSEMBLY STEP 6

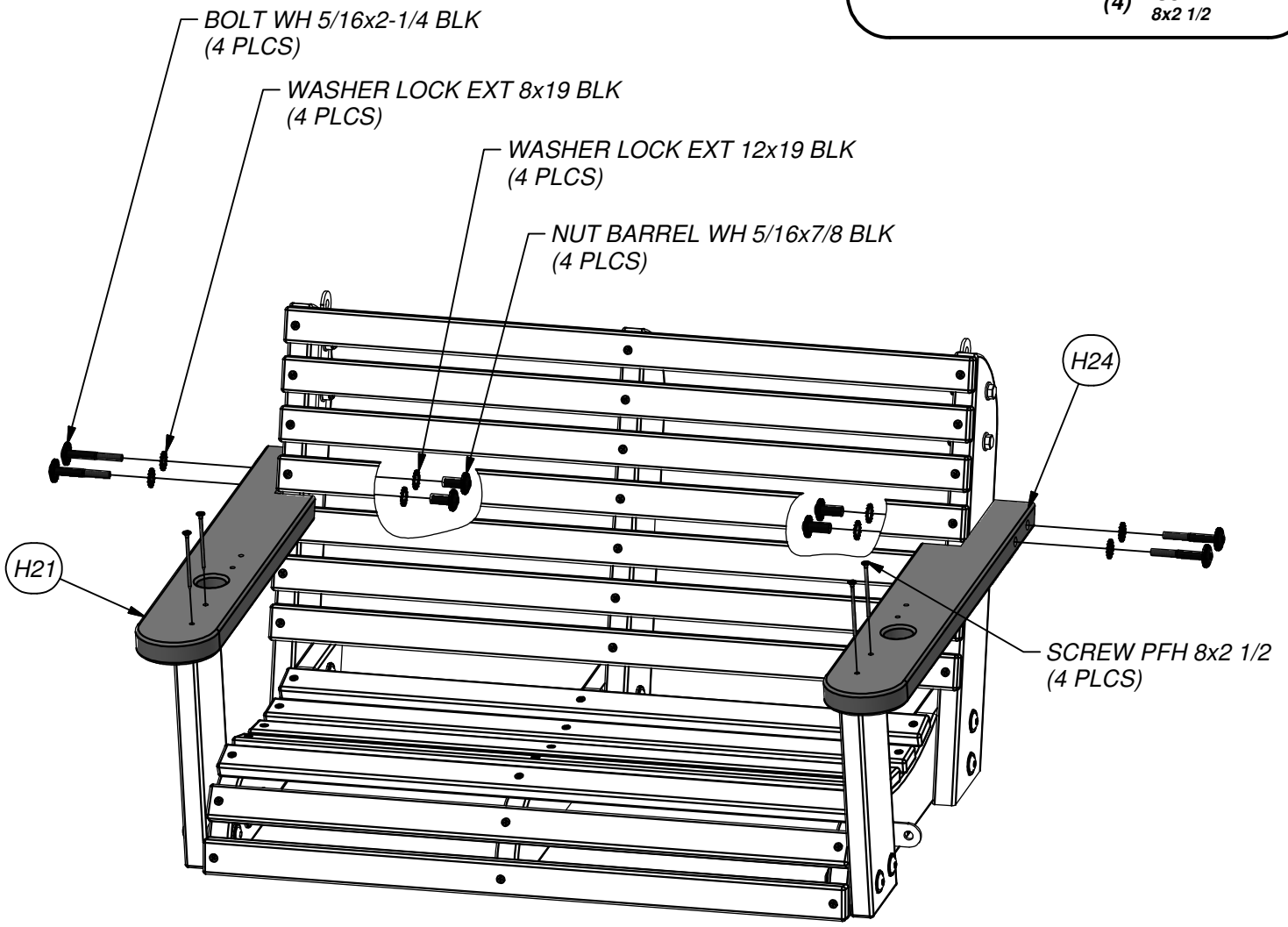
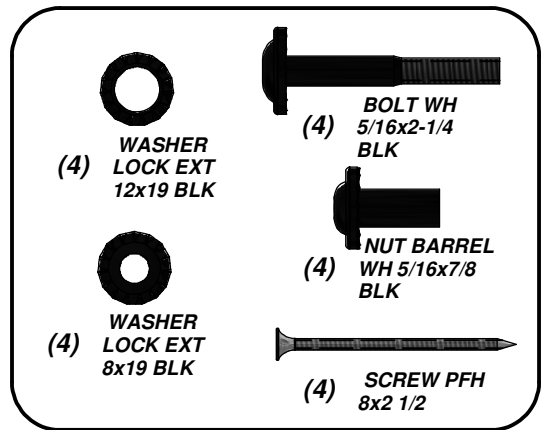



(2) J12 - SWING RAIL SUPPORT - W4L06342
1"x2 3/8"x9 1/8" (24x60x232)

SWING ASSEMBLY STEP 7

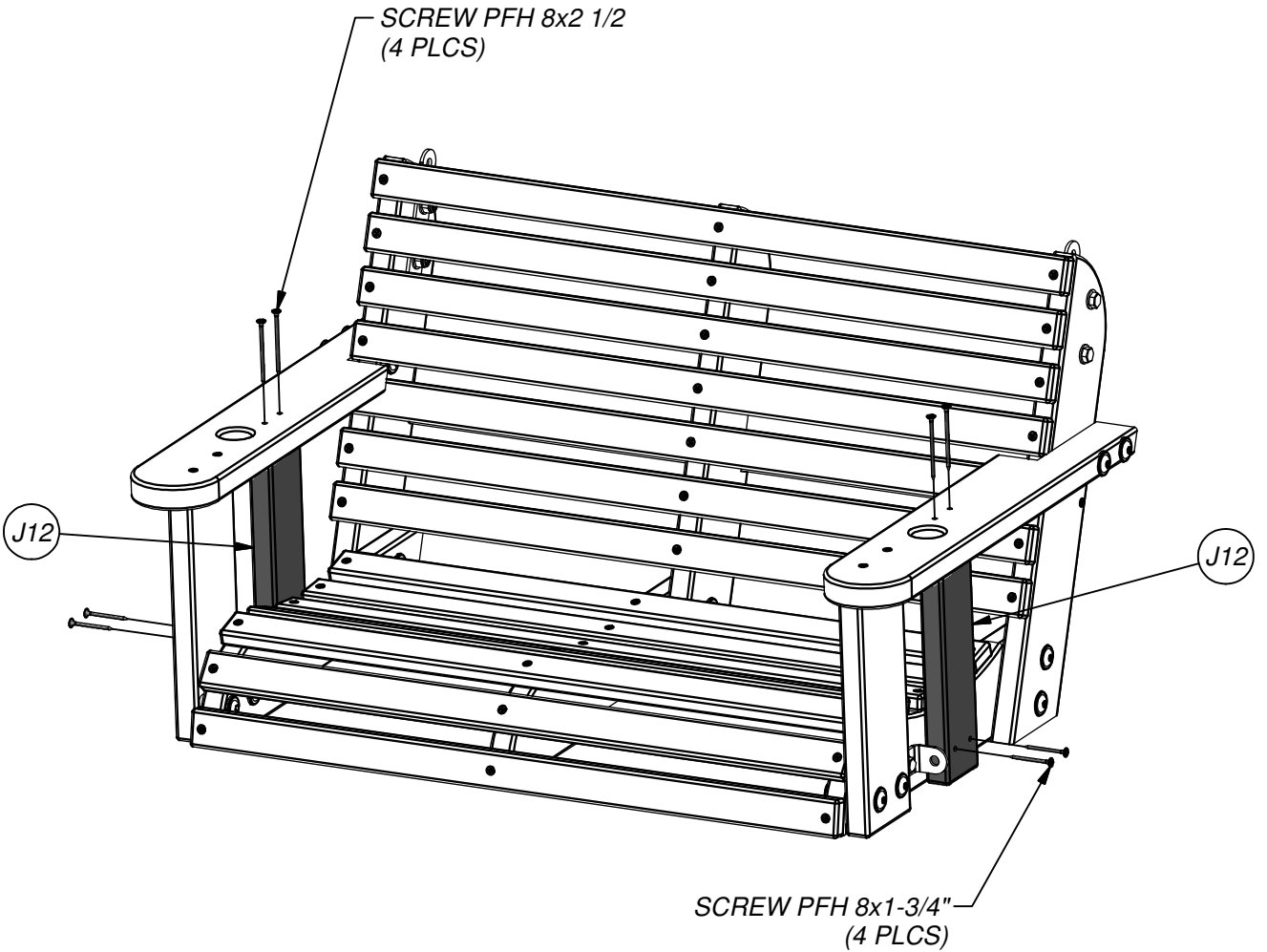
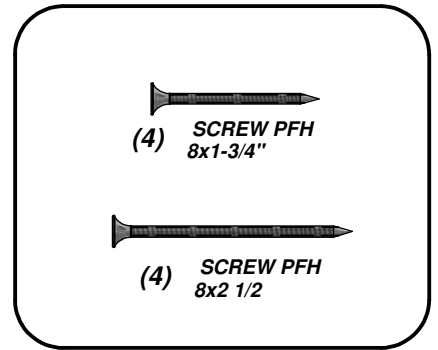



(1) A50 - SWING BEAM - W4L06169
3 3/8"x5 1/4"x89 1/2" (86x134x2274)



(2) - L BRACKET 66x66x127 - BLK - A4M00619



(1) - SWING BEAM EXTENSION BRACKET-LEFT - A4M00617



(1) - SWING BEAM EXTENSION BRACKET-RIGHT - A4M00618

SWING BEAM ASSEMBLY STEP 1

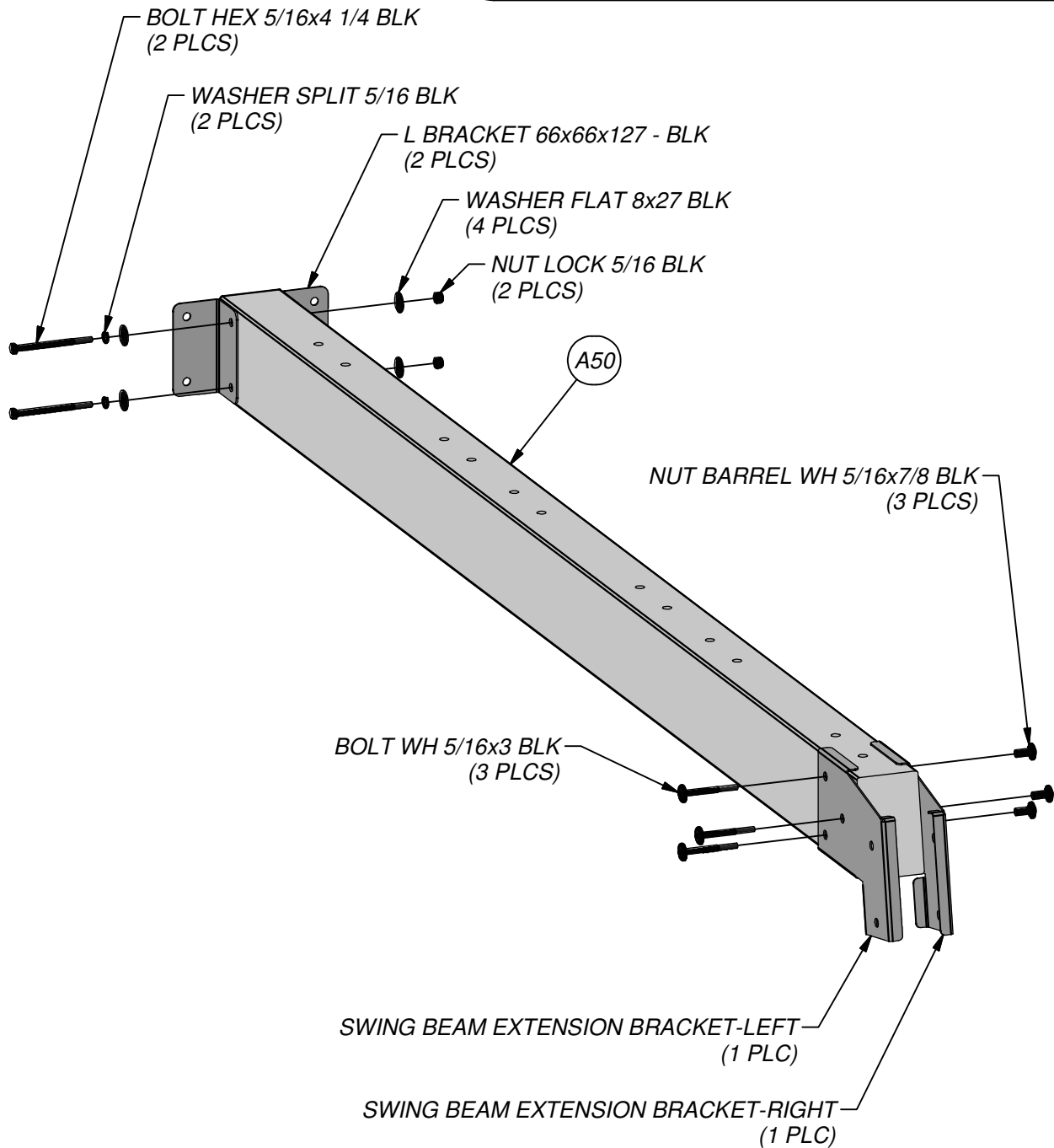
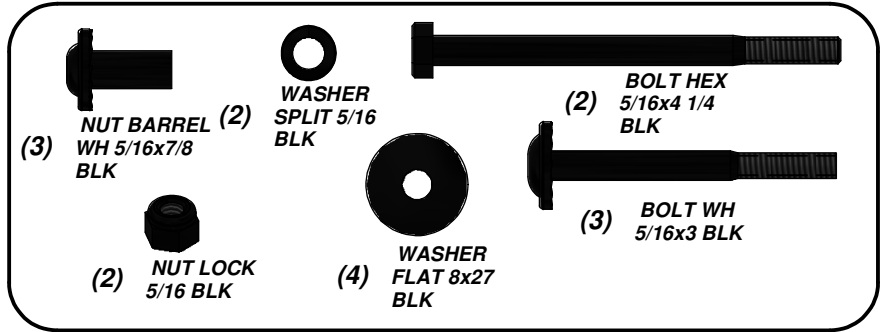

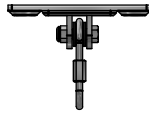

(6) - SWING HANGER- A4M00505

**SWING BEAM ASSEMBLY
STEP 2**

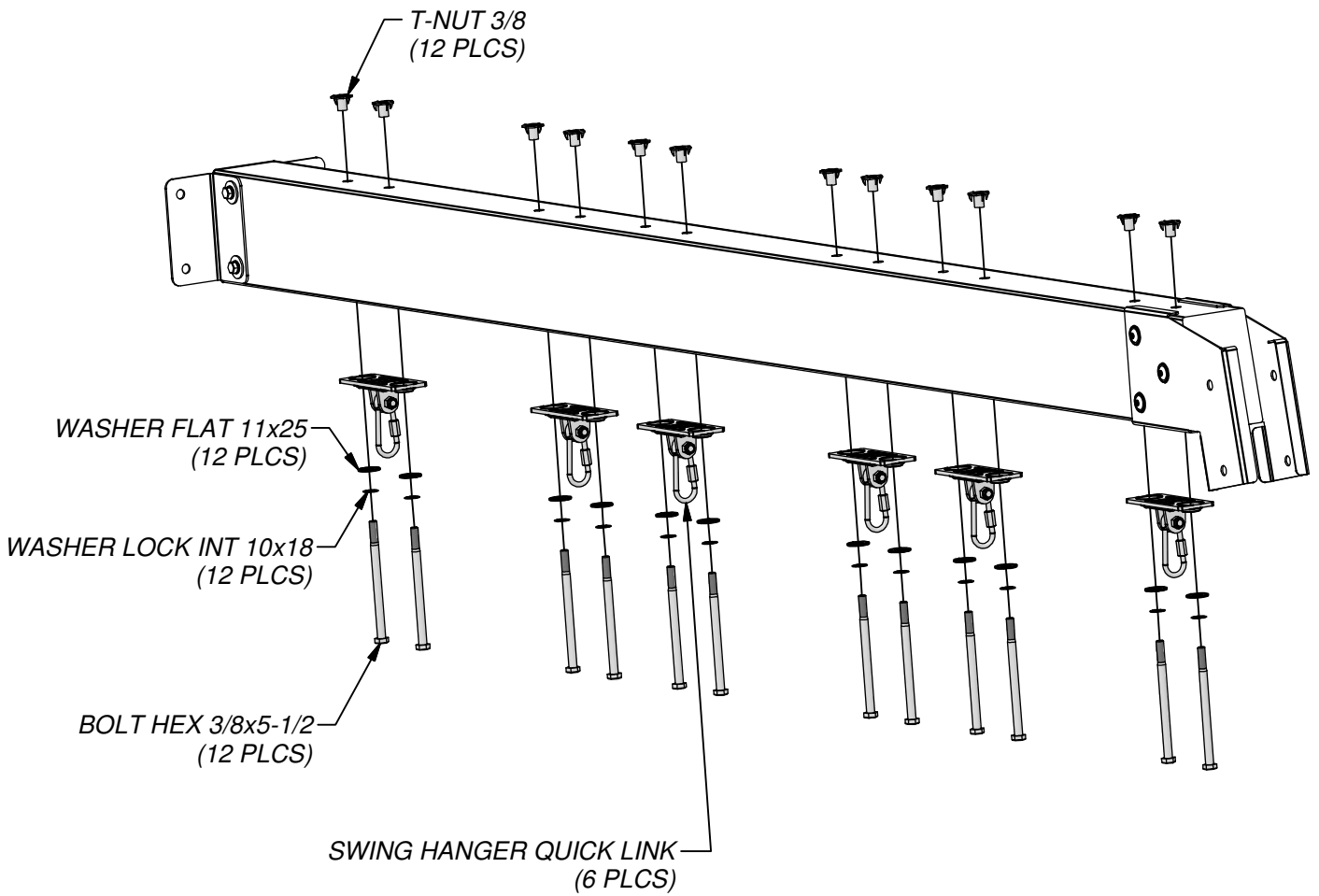
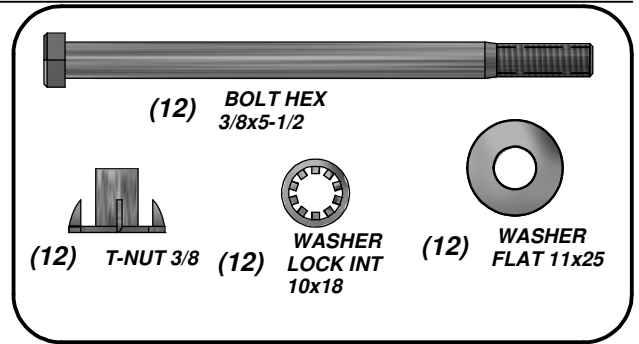

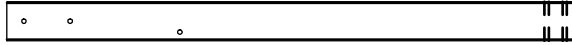

(1) **SP50 - SWING BEAM SUPPORT - W4L06170**
3 3/8"x3 3/8"x49 3/8" (86x86x1254)

SWING BEAM ASSEMBLY
STEP 3

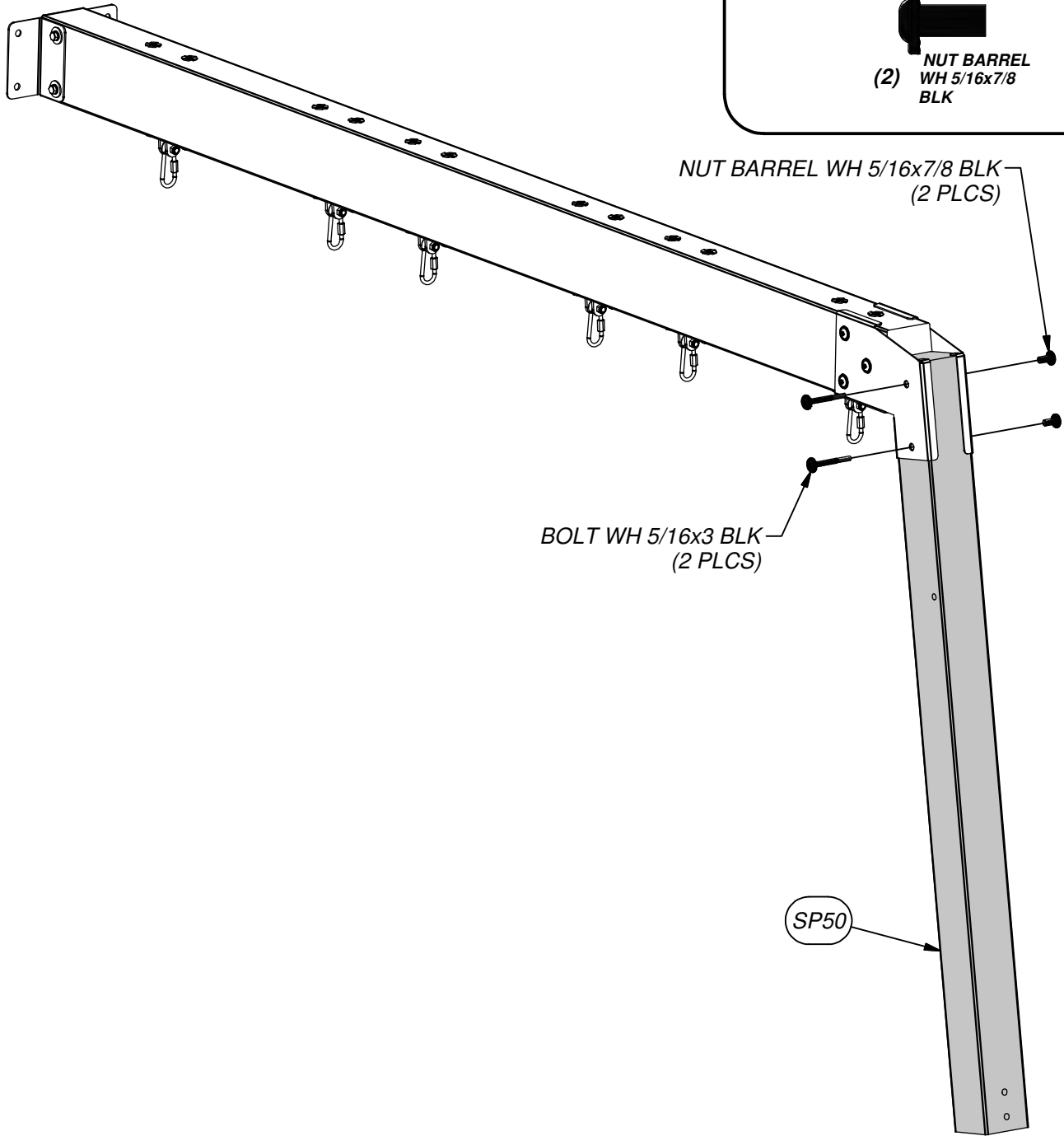
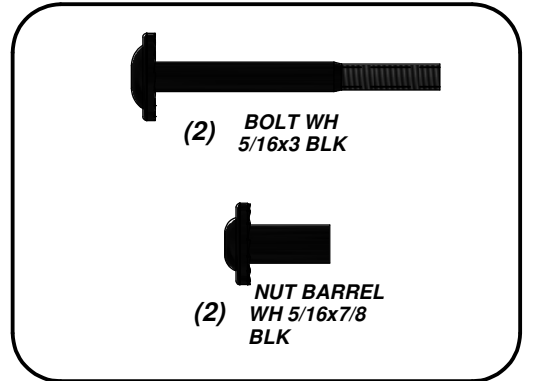

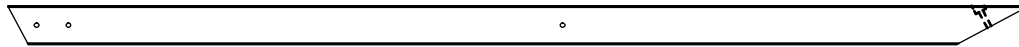

(2) **E51 - ANGLE BRACE - W4L06171**
 1 3/8"x3 3/8"x88 3/4" (36x86x2254)

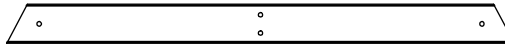

(1) **E50 - END SUPPORT - W4L06172**
 1 3/8"x3 3/8"x44 1/8" (36x86x1120)

**SWING BEAM ASSEMBLY
 STEP 4**

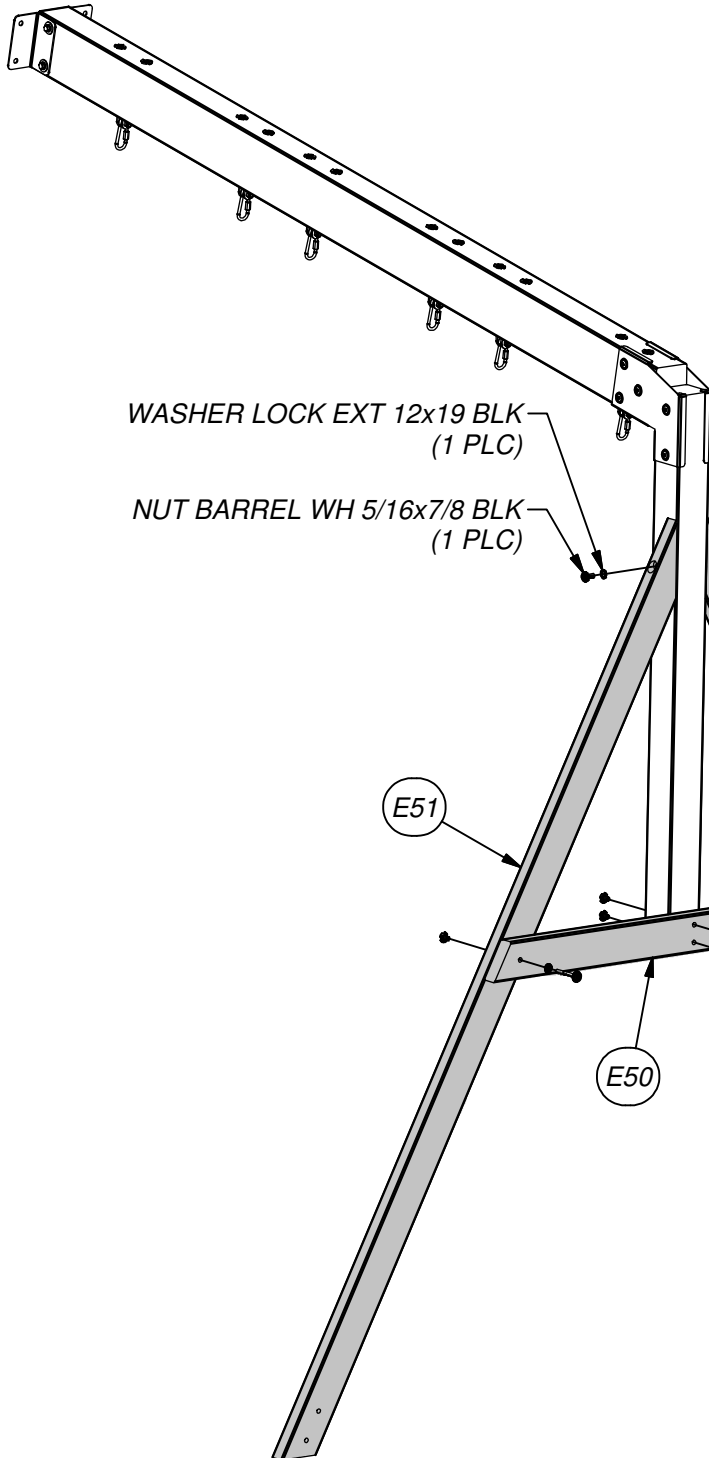

WASHER LOCK EXT 12x19 BLK
 (1 PLC)

NUT BARREL WH 5/16x7/8 BLK
 (1 PLC)

WASHER LOCK EXT 8x19 BLK
 (1 PLC)

BOLT WH 5/16X6 BLK
 (1 PLC)

T-NUT 5/16 BLK
 (4 PLCS)

BOLT WH 5/16x2-3/4 BLK
 (2 PLCS)

WASHER LOCK EXT 8x19 BLK
 (4 PLCS)

BOLT WH 5/16x4 3/4 BLK
 (2 PLCS)

(1) **BOLT WH 5/16X6 BLK**

(1) **WASHER LOCK EXT 12x19 BLK**

(2) **BOLT WH 5/16x4 3/4 BLK**

(4) **T-NUT 5/16 BLK**

(2) **BOLT WH 5/16x2-3/4 BLK**

(5) **WASHER LOCK EXT 8x19 BLK**

(1) **NUT BARREL WH 5/16x7/8 BLK**

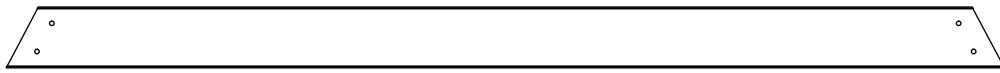

(1) **G50 - GROUND BOARD - W4L06173**
1"x5 1/4"x86 3/4" (24x134x2202)

SWING BEAM ASSEMBLY
STEP 5

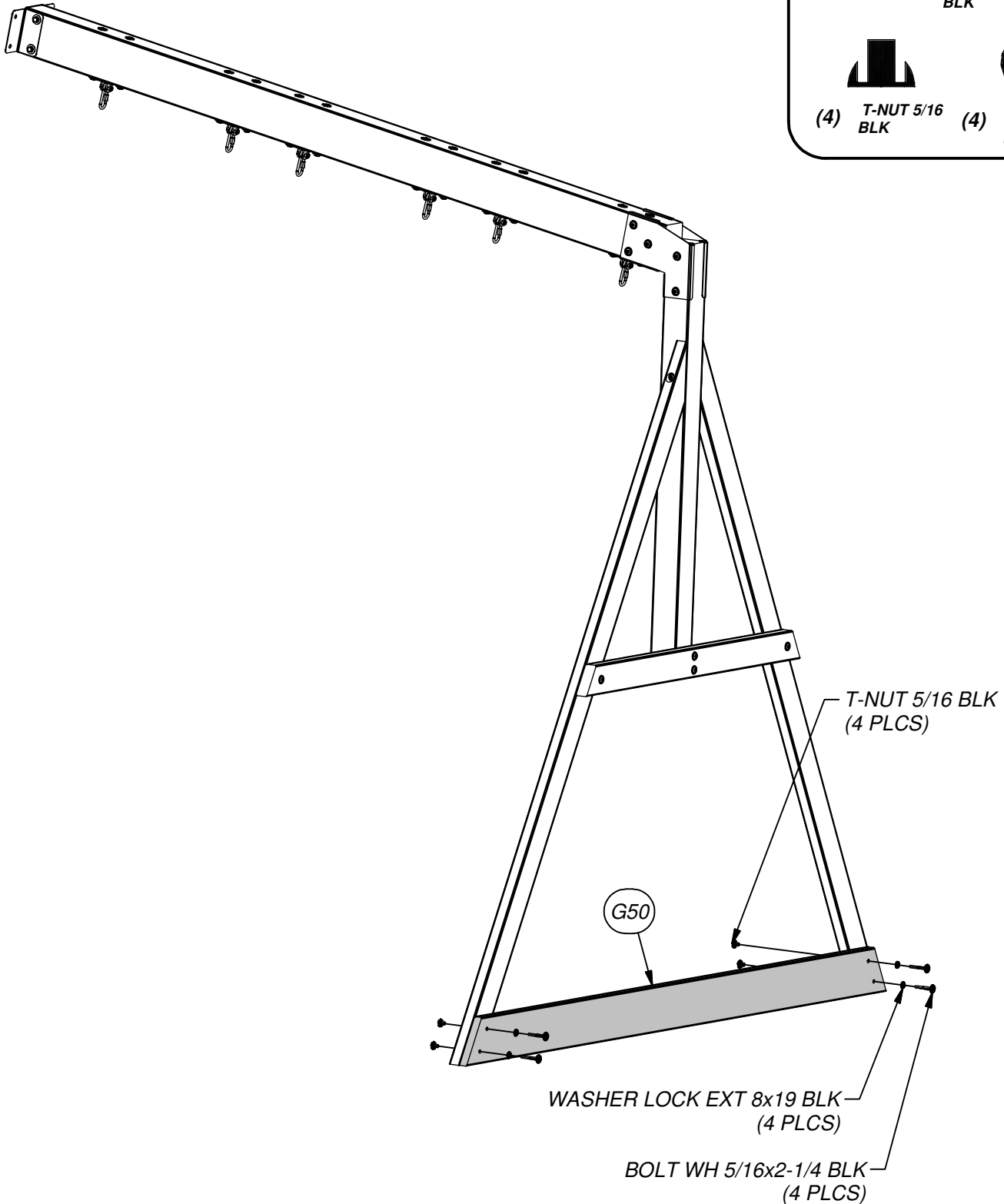
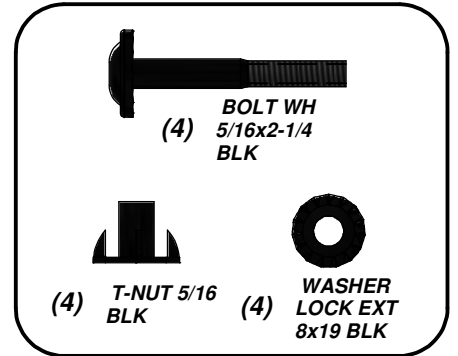



(1) SLIDE BED 10' LIGHT GREEN - A100035

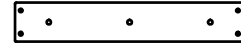

(1) M70 - SLIDE SUPPORT BOARD - W100935
5/8"x3 3/8"x19 7/8" (16x86x505)

STEP 1

10 FOOT SLIDE ASSEMBLY

NOTE:
TAKE NOTE OF SLIDE BED SURFACE FINISH, THE DULL SIDE WILL BE TOWARDS THE GROUND. PLACE SLIDE BRACE CENTERED ON THE BOTTOM (DULL SIDE) AND 1/2" FROM THE EDGE. USE M70 BOARD AS A TEMPLATE FOR DRILLING BOTTOM HOLE PATTERN IN SLIDE BED. USE A 5/16" DRILL BIT.

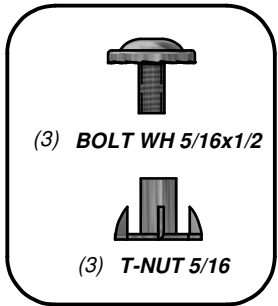

(3) BOLT WH 5/16x1/2

(3) T-NUT 5/16

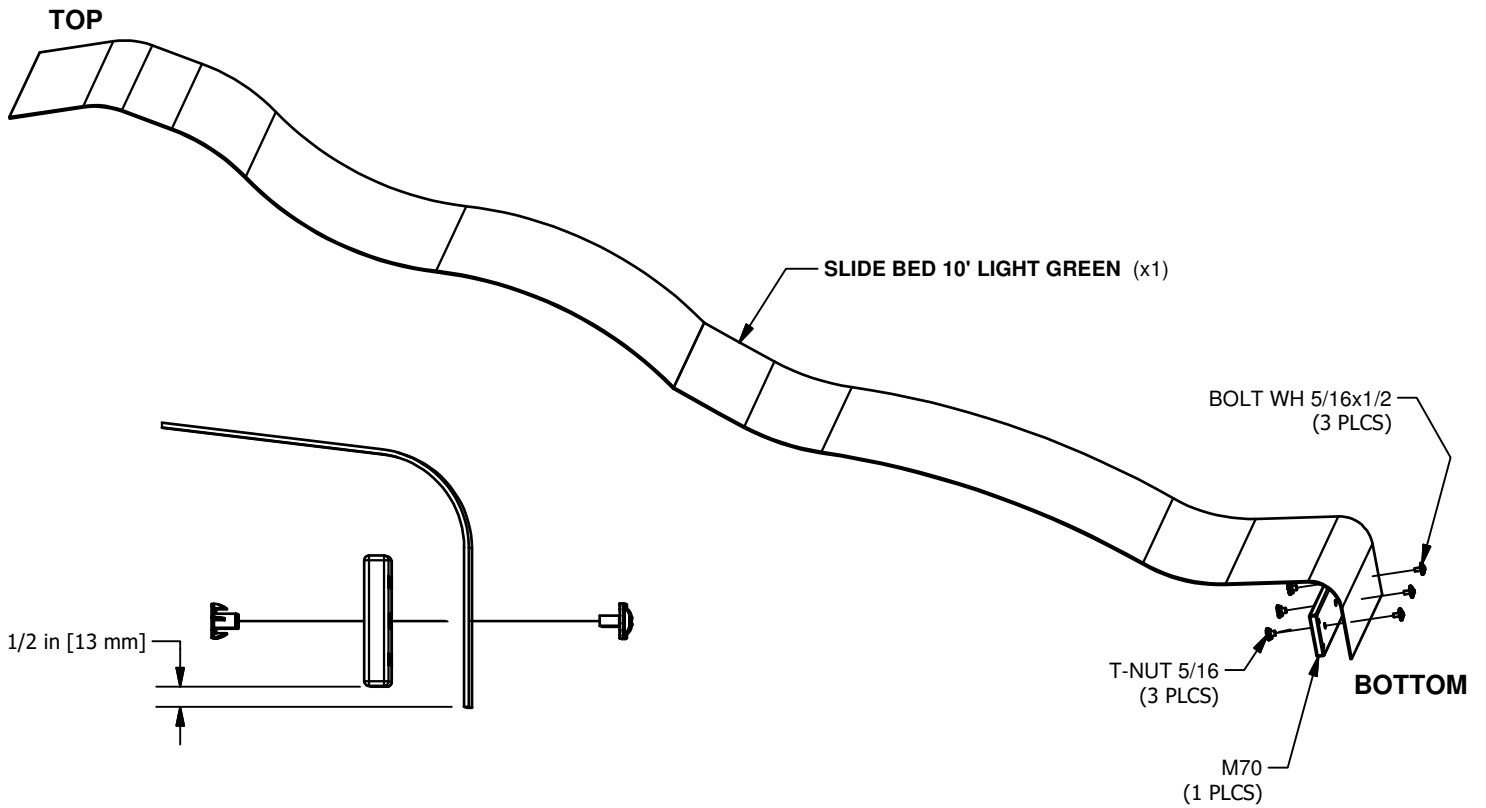

TIP:
PRE-BENDING THE ENDS WILL EASE ASSEMBLY. PLACING THE SLIDE BED OUT IN THE SUN MAKES IT EASIER TO BEND.

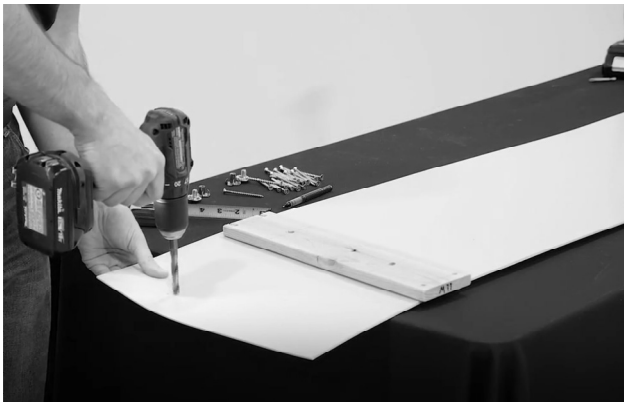

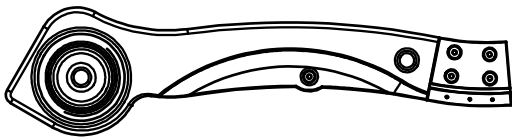

(1) SLIDE RAIL 10' BOTTOM RIGHT GREEN - A6P00484

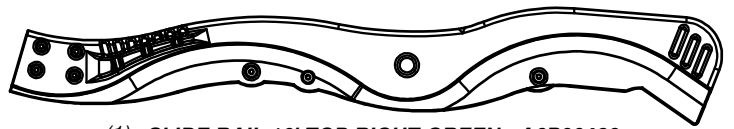

(1) SLIDE RAIL 10' TOP RIGHT GREEN - A6P00486

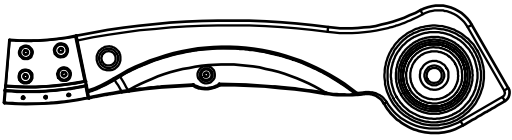

(1) SLIDE RAIL 10' BOTTOM LEFT GREEN - A6P00483

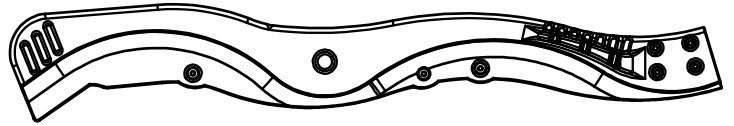

(1) SLIDE RAIL 10' TOP LEFT GREEN - A6P00485

STEP 2

10 FOOT SLIDE ASSEMBLY

NOTE:
REPEAT ON OTHER SIDE, MAKING
A LEFT AND RIGHT ASSEMBLY.

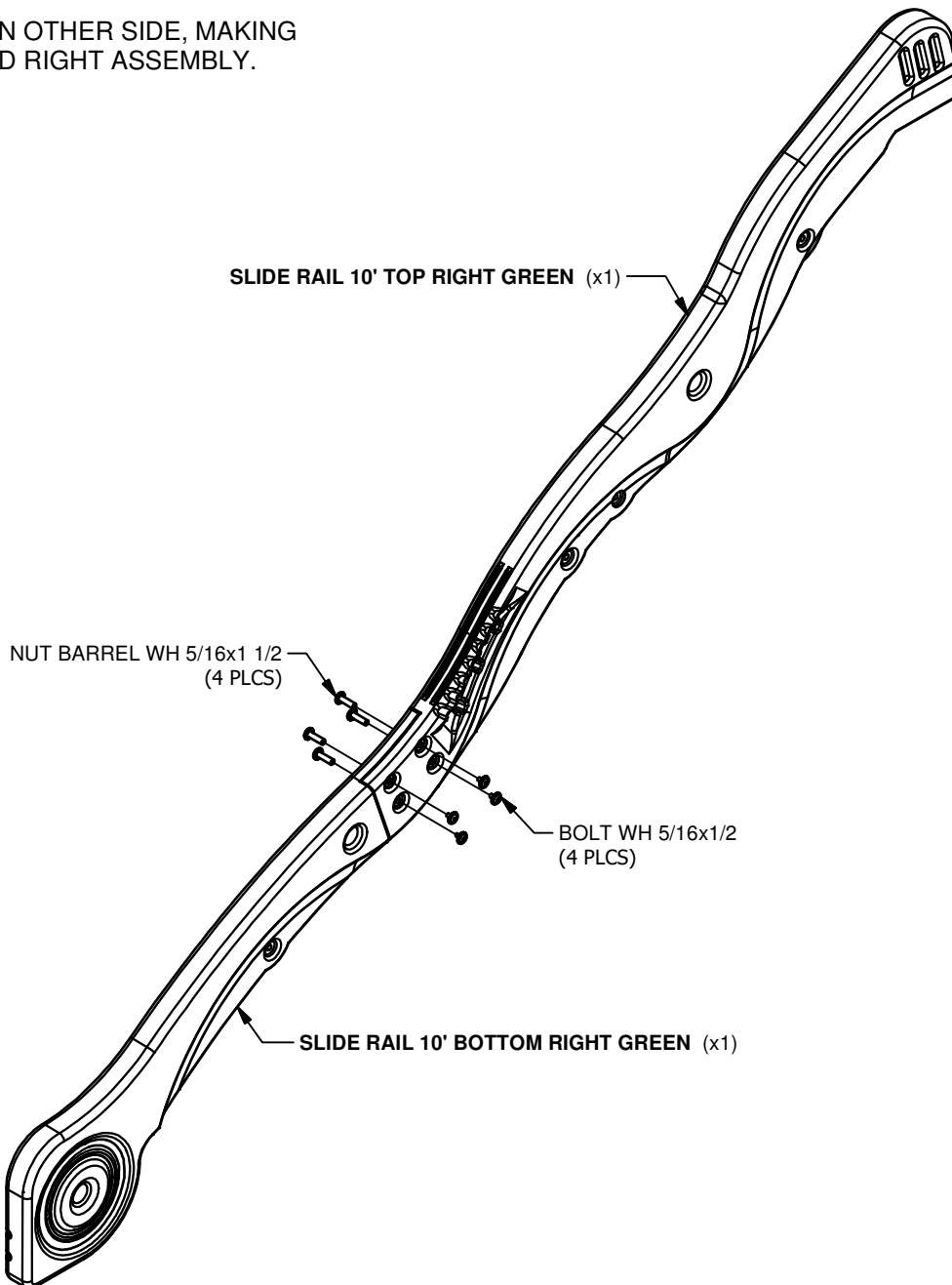
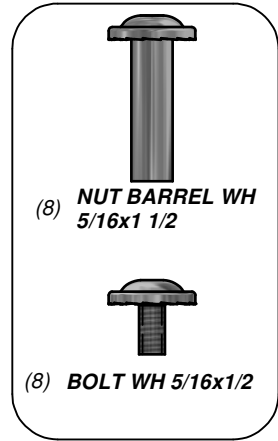

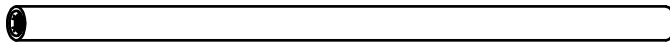

A6P00487 | SLIDE TUBE SUPPORT
(x4)

STEP 3

10 FOOT SLIDE ASSEMBLY

NOTE:
INSERT THE (4) SLIDE SUPPORT TUBES INTO THEIR RESPECTIVE PILOT LOCATIONS (FIGURE 1).

PLACE (1) SLIDE RAIL ASSEMBLY ON A FLAT SURFACE AND BEGIN INSERTING SLIDE BED AT THE BOTTOM OF THE SLIDE RAIL (FIGURE 2). HAVE A HELPER BEND THE SLIDE BED TOWARDS THE TOP OF THE SLIDE AND INSERT THE BED INTO THE SLIDE CAVITY. MAKE SURE SLIDE BED IS INSERTED WITHIN 1/8" (3mm) OF GROOVE BOTTOM.

TIP:
A HELPER IS RECOMMENDED FOR THESE FOLLOWING STEPS.

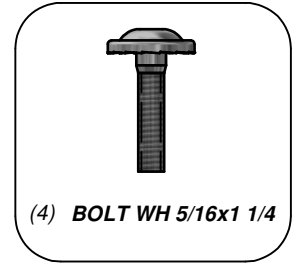

(4) BOLT WH 5/16x1 1/4

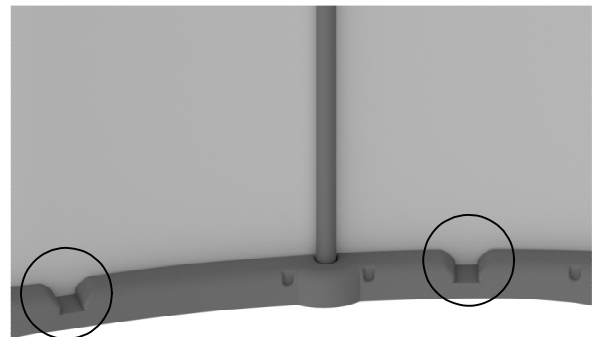
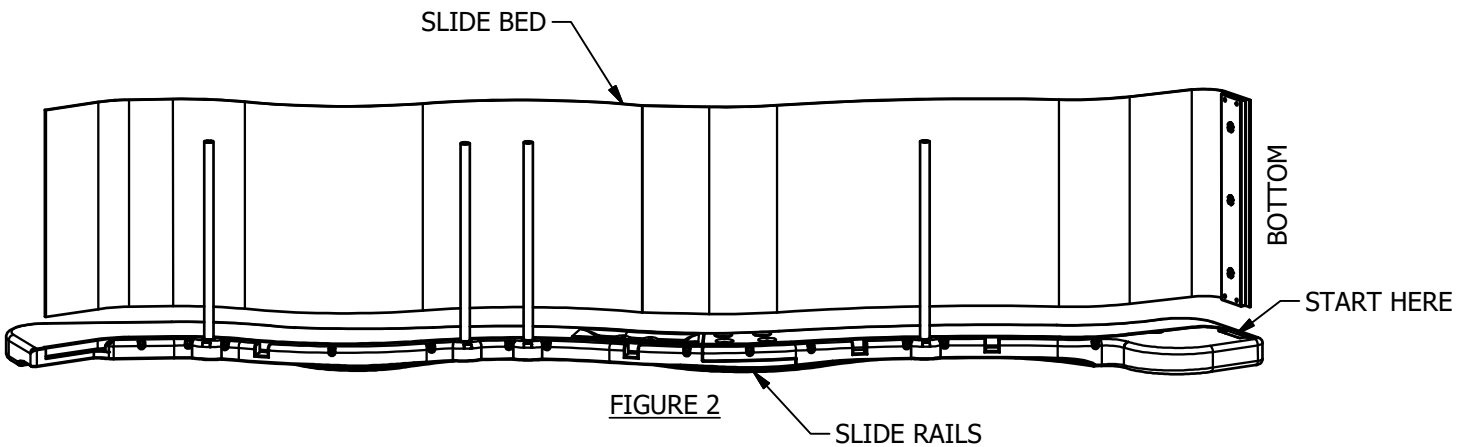
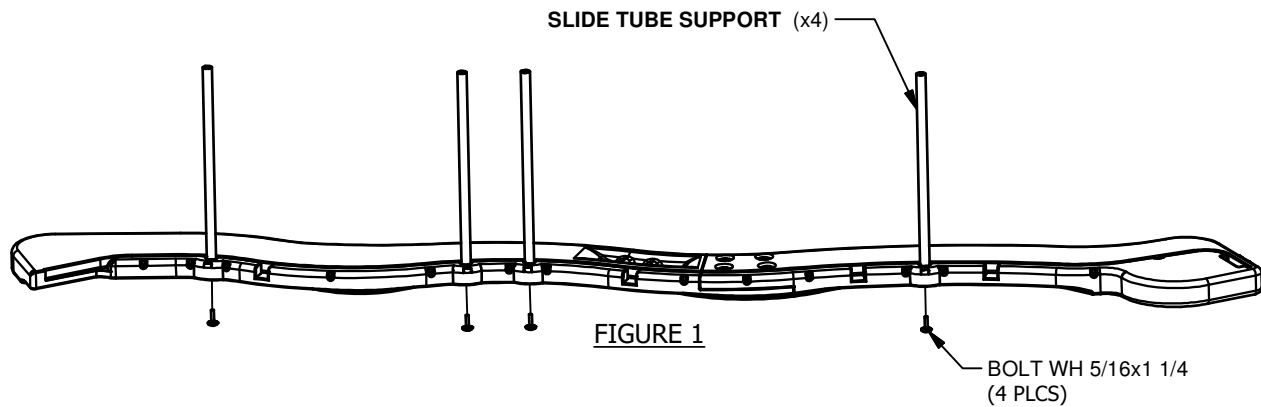

VIEWING WINDOWS

MAKE SURE SLIDE BED IS FULLY INSERTED

10 FOOT SLIDE ASSEMBLY

NOTE:

PLACE SECOND SLIDE RAIL ASSEMBLY OVER THE TOP OF THE SLIDE BED AND SLIDE SUPPORT TUBES. INSERT THE SLIDE BED AND SLIDE SUPPORT TUBES INTO THE SLIDE CAVITY. MAKE SURE SLIDE BED IS INSERTED WITHIN 1/8" (3mm) OF GROOVE BOTTOM.



FAILURE TO INSERT SLIDE BED PROPERLY MAY RESULT IN INJURY OR AMPUTATION. EXPOSED SLIDE EDGES CAN BE SHARP AND BECOME A LACERATION HAZARD IF THE SLIDE IS NOT PROPERLY ASSEMBLED.

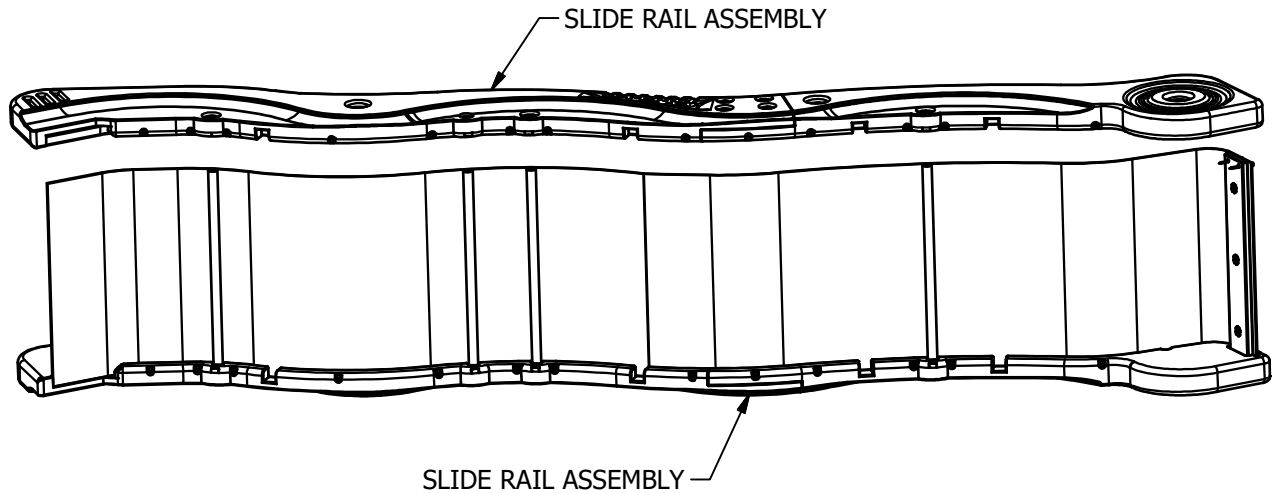

TIP:
USE A RUBBER Mallet TO FULLY SEAT THE SLIDE BED INTO THE SLIDE CAVITY.

STEP 5

10 FOOT SLIDE ASSEMBLY

NOTE:
USE 1 1/4" BOLTS TO FASTEN EACH
SIDE OF THE SLIDE SUPPORT TUBES.

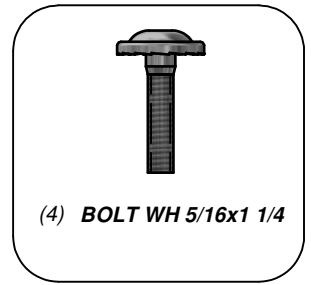

TIP:
HAVING A HELPER HOLD THE SLIDE
ASSEMBLY TOGETHER WHILE YOU FASTEN
WILL MAKE IT EASIER TO ASSEMBLE.

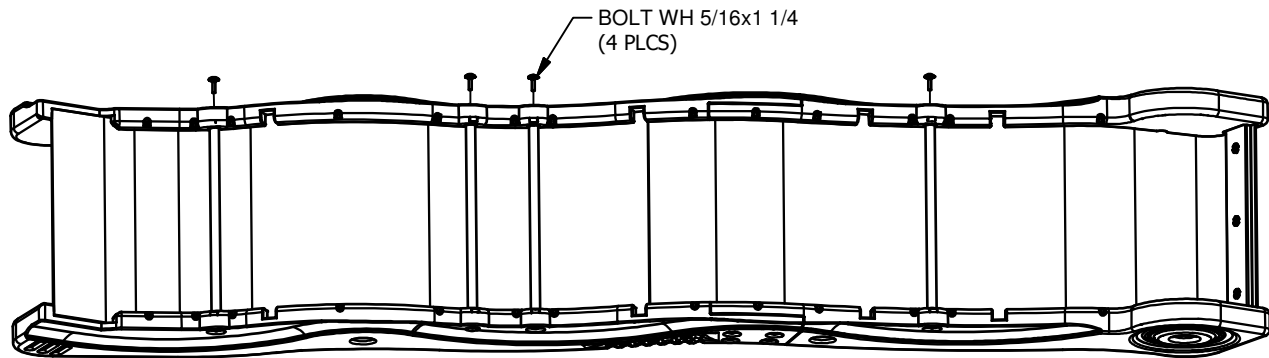

NOTE:
USING AN 1/8" DRILL BIT, DRILL PILOT HOLES IN EACH INDENTATION
ALONG EACH SIDE RAIL. THERE SHOULD BE 15 INDENTATIONS ON
EACH RAIL. BE SURE TO DRILL THROUGH THE SLIDE RAIL AND THE
SLIDE BED. THEN SECURE WITH THE PROVIDED HARDWARE.

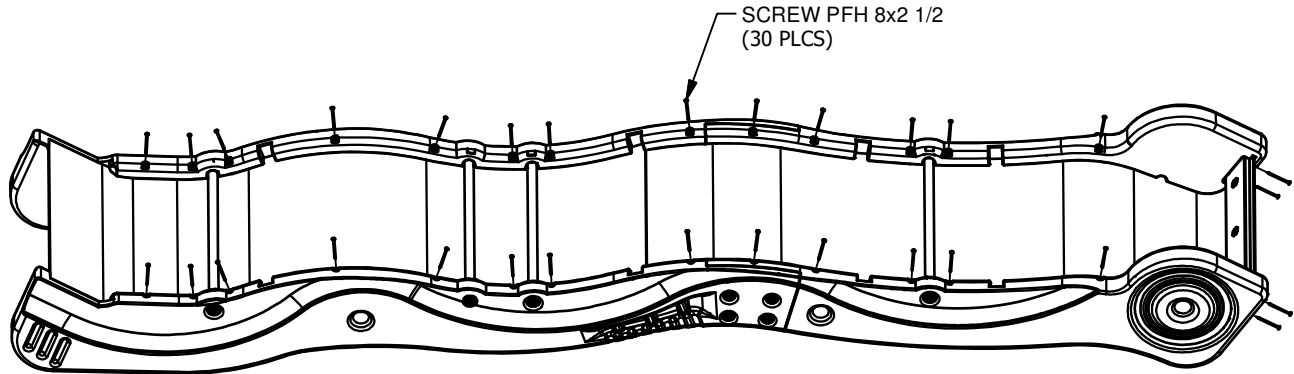
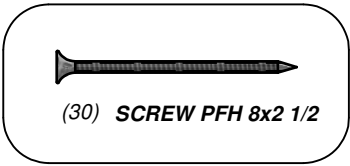

(1) **E12 - UPRIGHT - W2A01864**
 1 3/8"x3 3/8"x57 3/8" (36x86x1457)

(1) **E7 - UPRIGHT - W4L06051**
 1 3/8"x3 3/8"x57 3/8" (36x86x1457)

(1) **H2 - FLOOR SUPPORT - W4L06060**
 1"x3 3/8"x76 3/4" (24x86x1948)

(1) **K12 - GROUND BOARD - W4L06185**
 5/8"x5 1/4"x89 1/2" (16x134x2274)

STEP 1

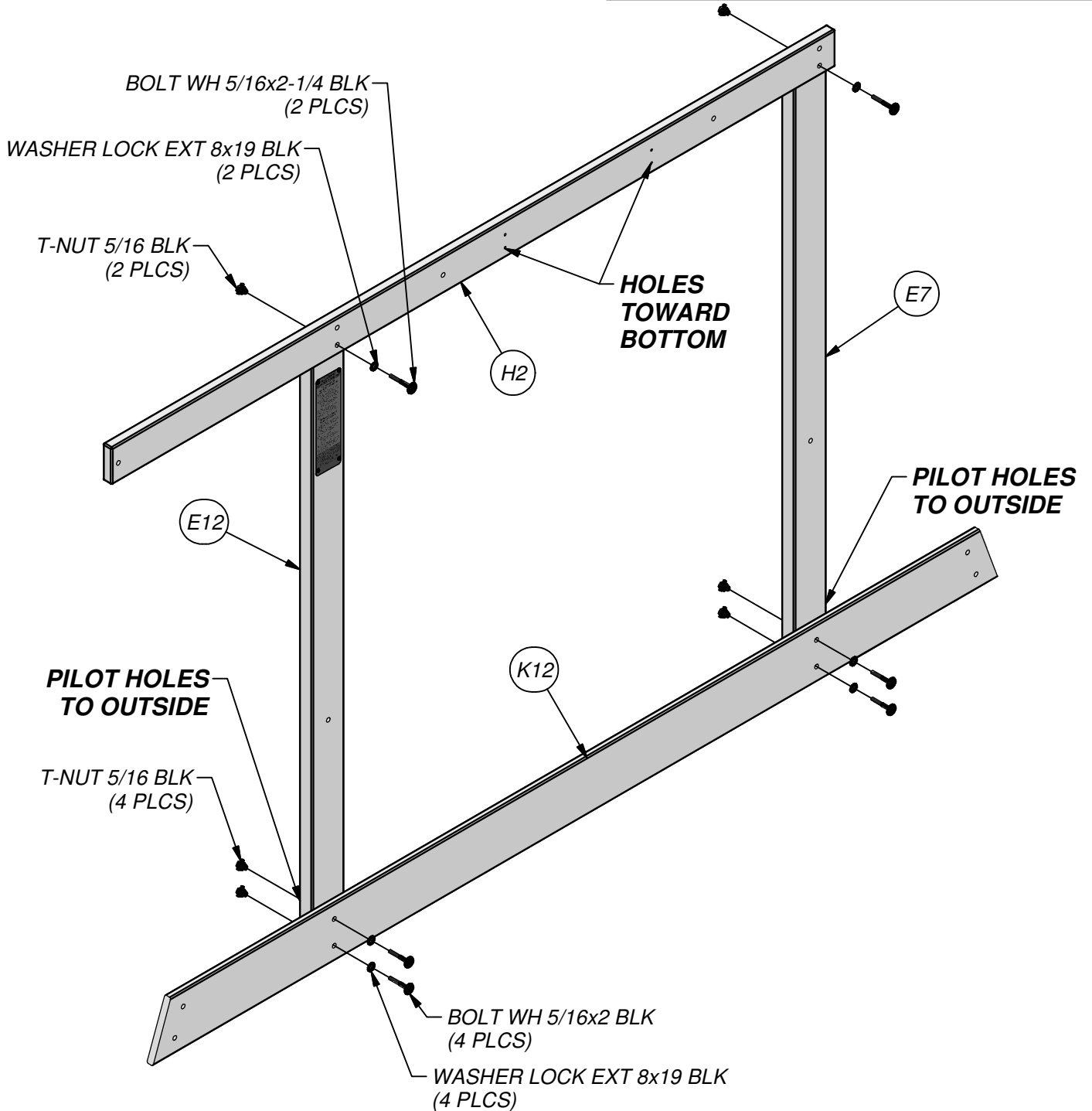
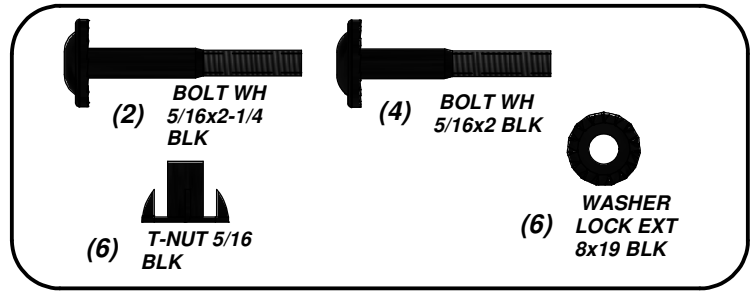



(2) **H22 - DECK BRACE - W4L06082**
1"x3 3/8"x18 3/8" (24x86x466)

STEP 2

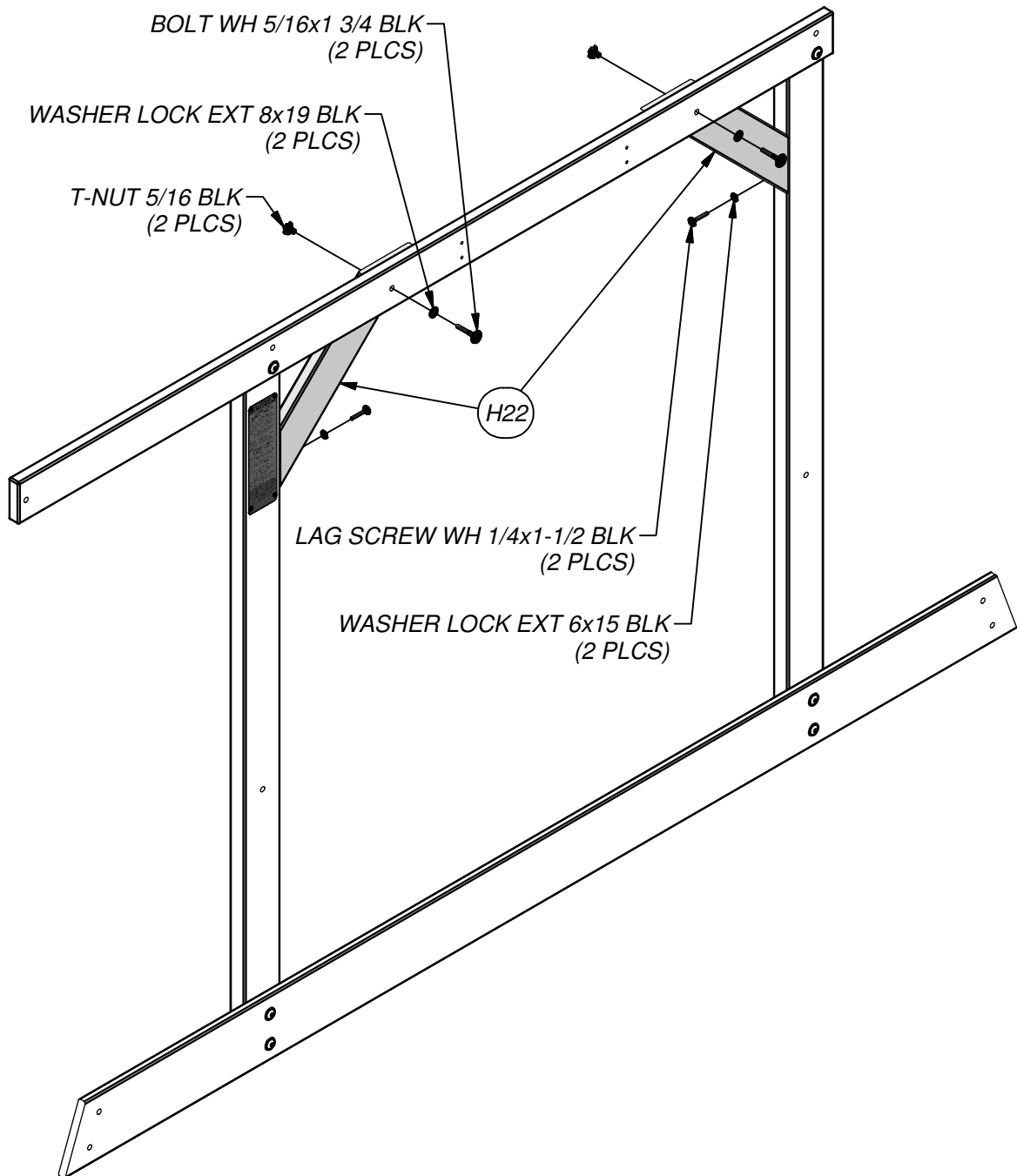
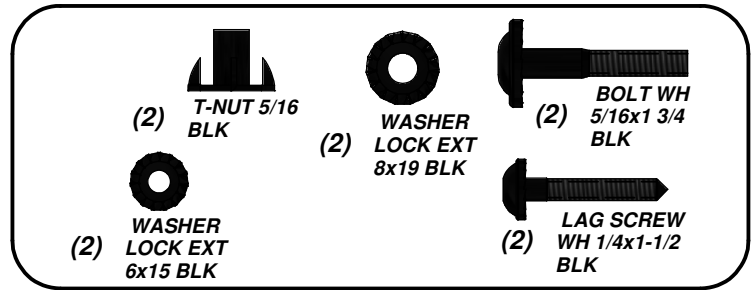



(1) **K1 - GROUND BOARD - W4L06052**
5/8"x5 1/4"x74 1/2" (16x134x1893)

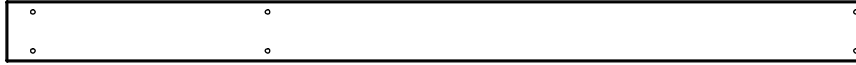

(1) **K2 - GROUND BOARD - W4L06056**
5/8"x5 1/4"x74 1/2" (16x134x1893)

STEP 3

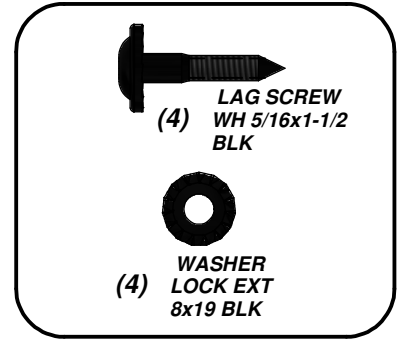

LAG SCREW
(4) WH 5/16x1-1/2
BLK

**WASHER
LOCK EXT**
(4) 8x19 BLK

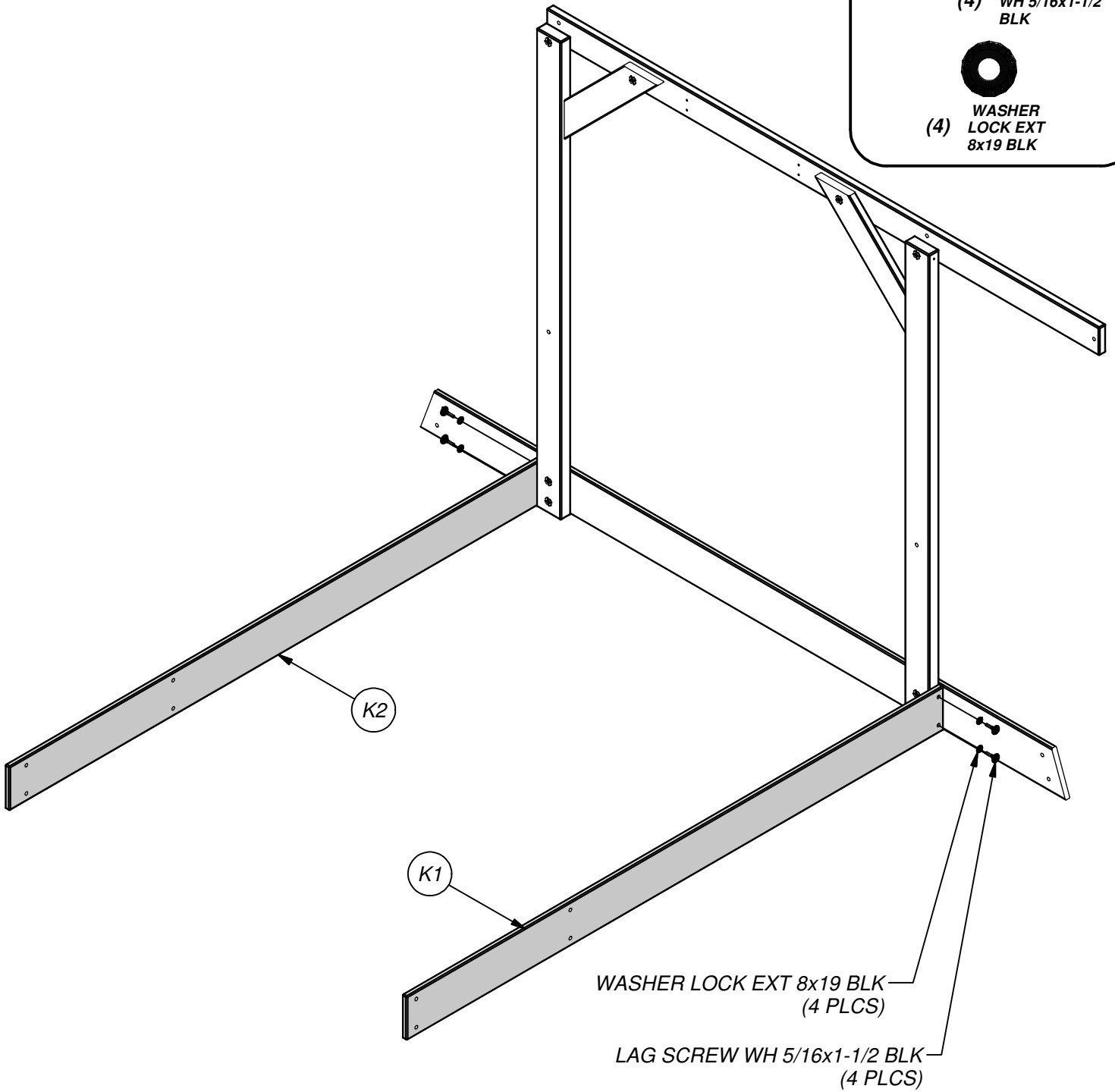



(1) **E8 - UPRIGHT - W4L06058**
1 3/8"x3 3/8"x57 3/8" (36x86x1457)



(1) **K4 - GROUND BOARD - W4L06049**
5/8"x5 1/4"x54 1/2" (16x134x1384)

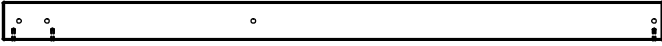

(1) **E9 - UPRIGHT - W4L06061**
1 3/8"x3 3/8"x57 3/8" (36x86x1457)

STEP 4

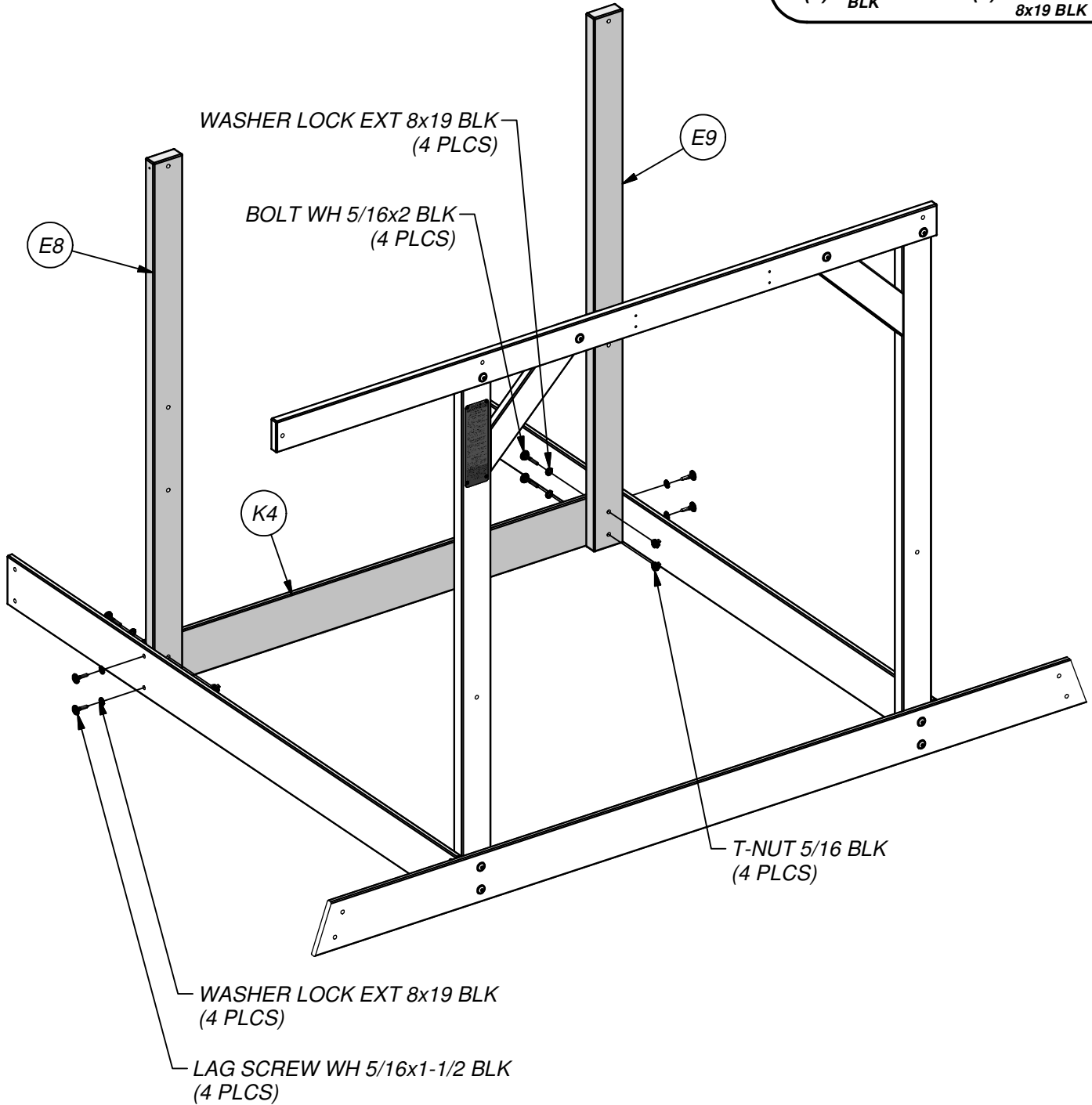
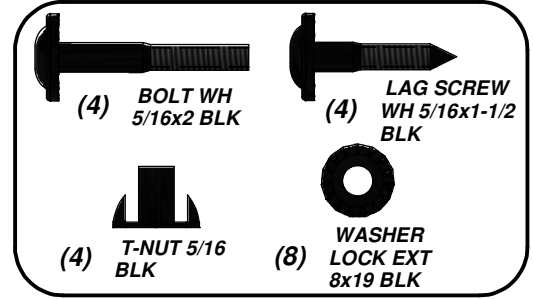



(1) **E2 - UPRIGHT - W4L06190**
1 3/8"x3 3/8"x86 1/8" (36x86x2186)

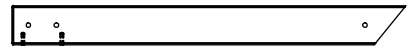

(1) **E10 - UPRIGHT - W4L06053**
1 3/8"x3 3/8"x34 1/4" (36x86x869)

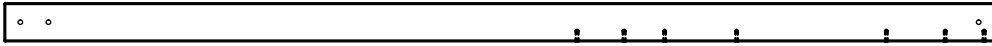

(1) **E1 - UPRIGHT - W4L06195**
1 3/8"x3 3/8"x86 1/8" (36x86x2186)



(1) **K5 - GROUND BOARD - W4L06054**
5/8"x5 1/4"x54 1/2" (16x134x1384)

STEP 5

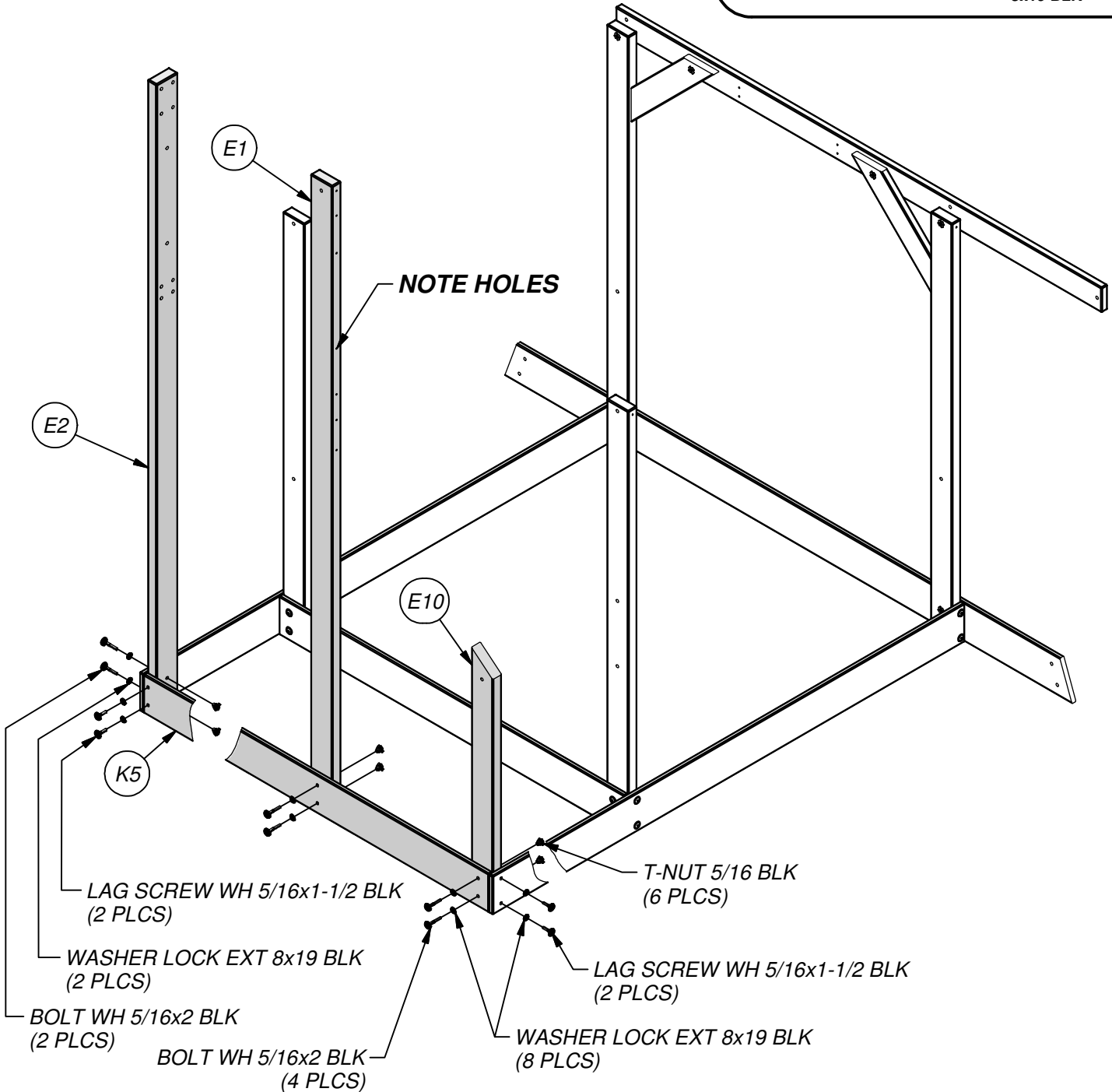
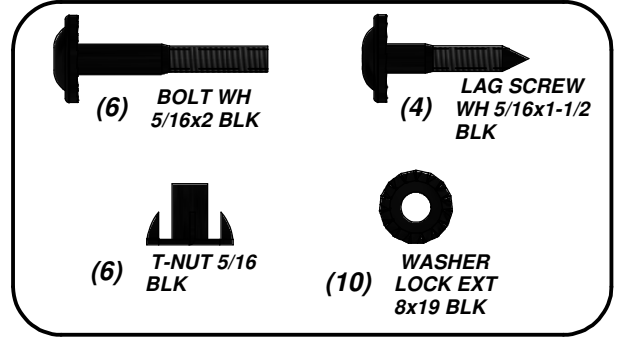



(1) **H3 - FLOOR SUPPORT - W4L06352**
1"x3 3/8"x76 3/4" (24x86x1948)

STEP 6

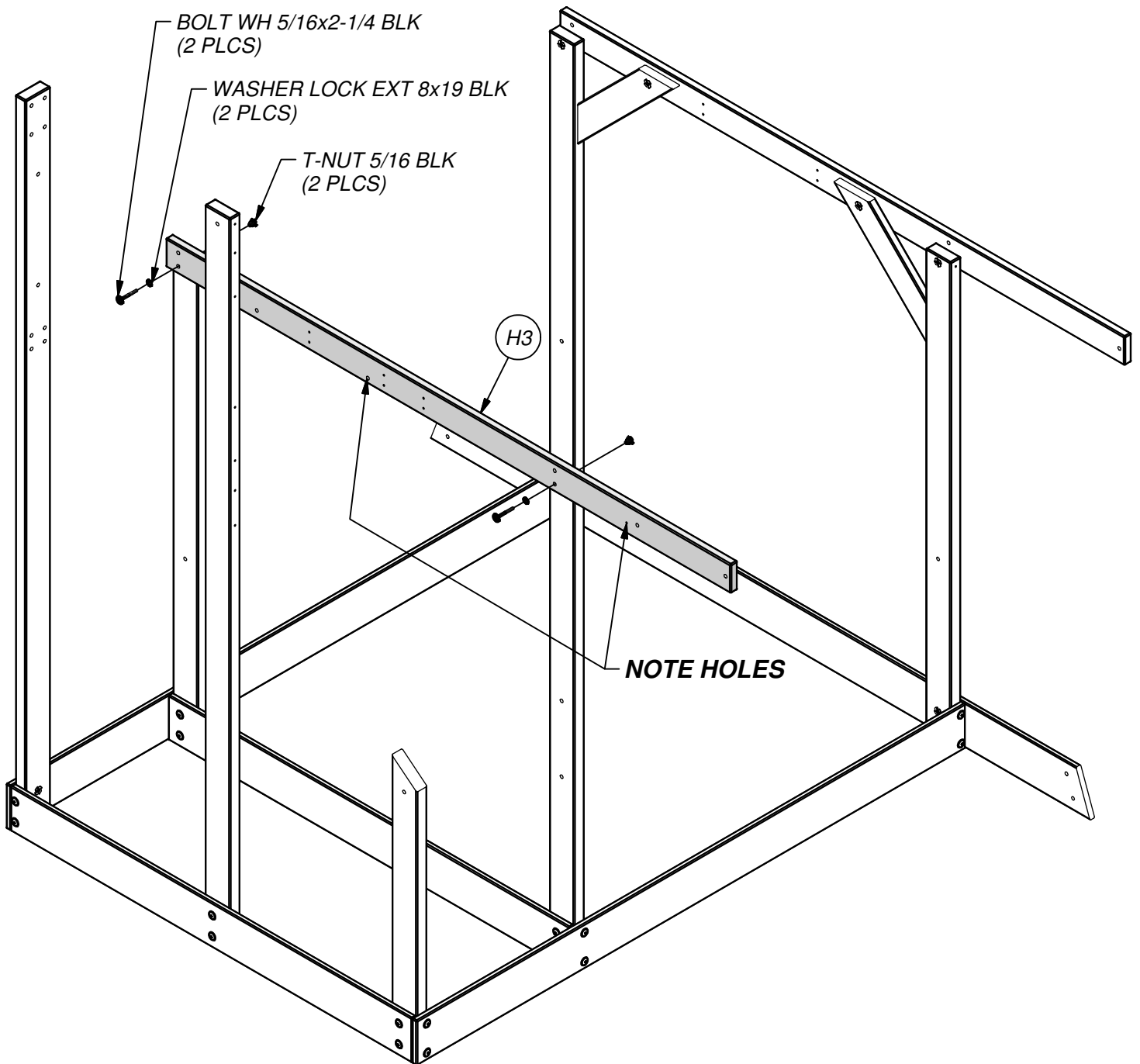
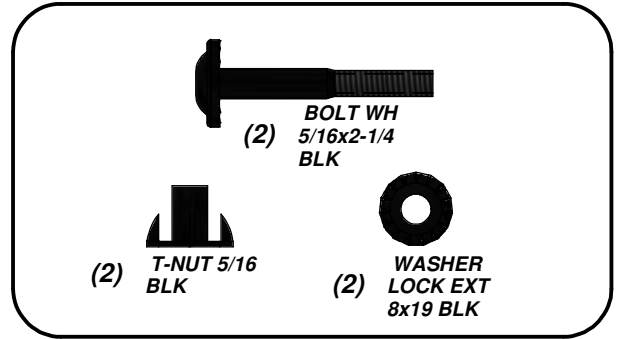



(1) **H22 - DECK BRACE - W4L06082**
1"x3 3/8"x18 3/8" (24x86x466)

STEP 7

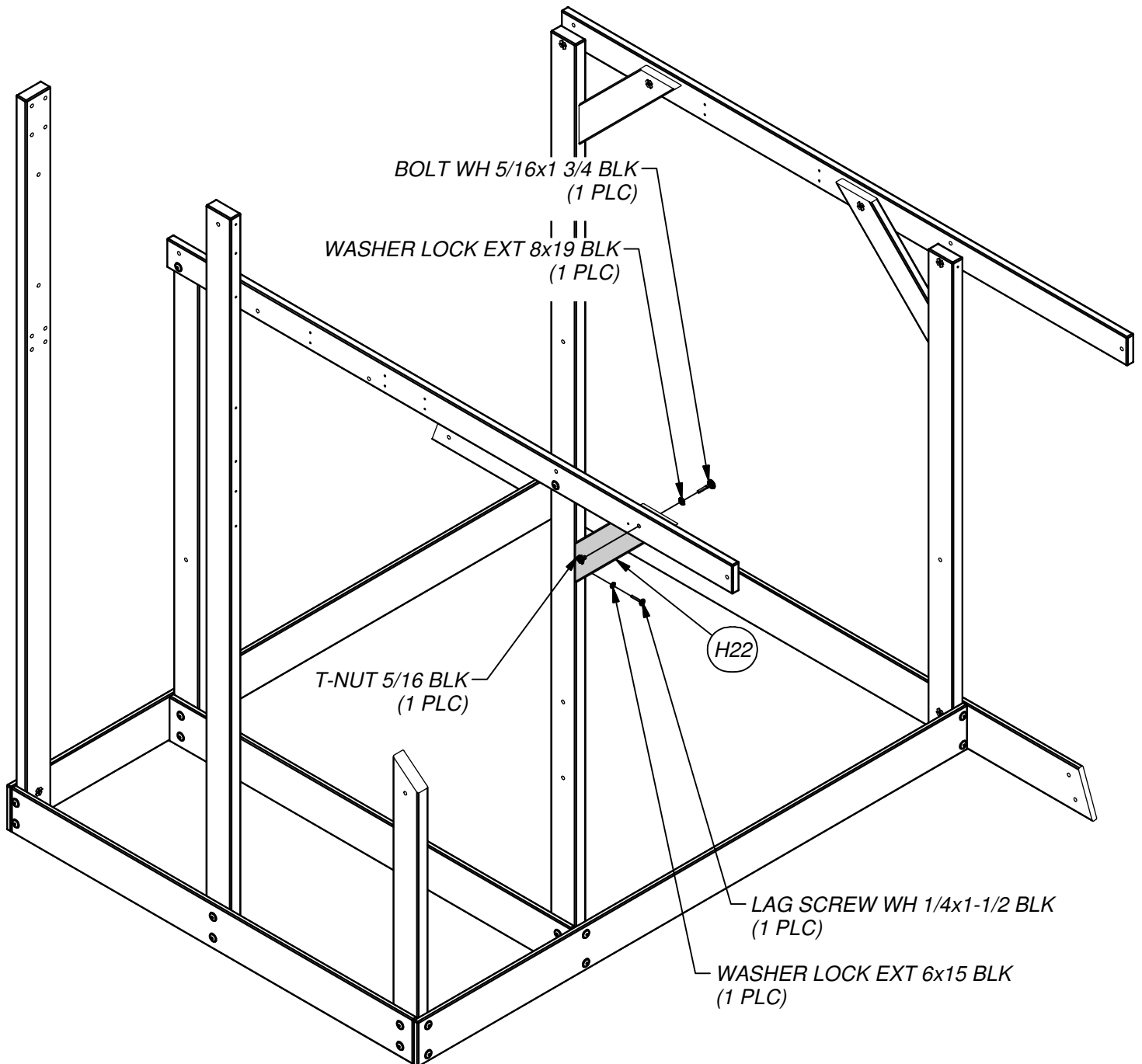
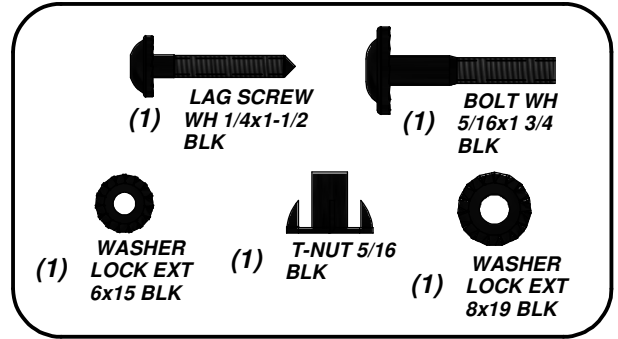

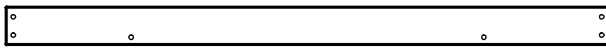

(1) **H10 - FLOOR SUPPORT - W4L06062**
1"x3 3/8"x52 1/2" (24x86x1334)

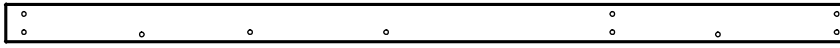

(1) **H4 - FLOOR SUPPORT - W4L06189**
1"x3 3/8"x73 1/8" (24x86x1858)

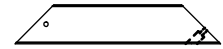

(4) **H23 - DECK BRACE - W4L06179**
1"x3 3/8"x17 7/8" (24x86x453)

STEP 8

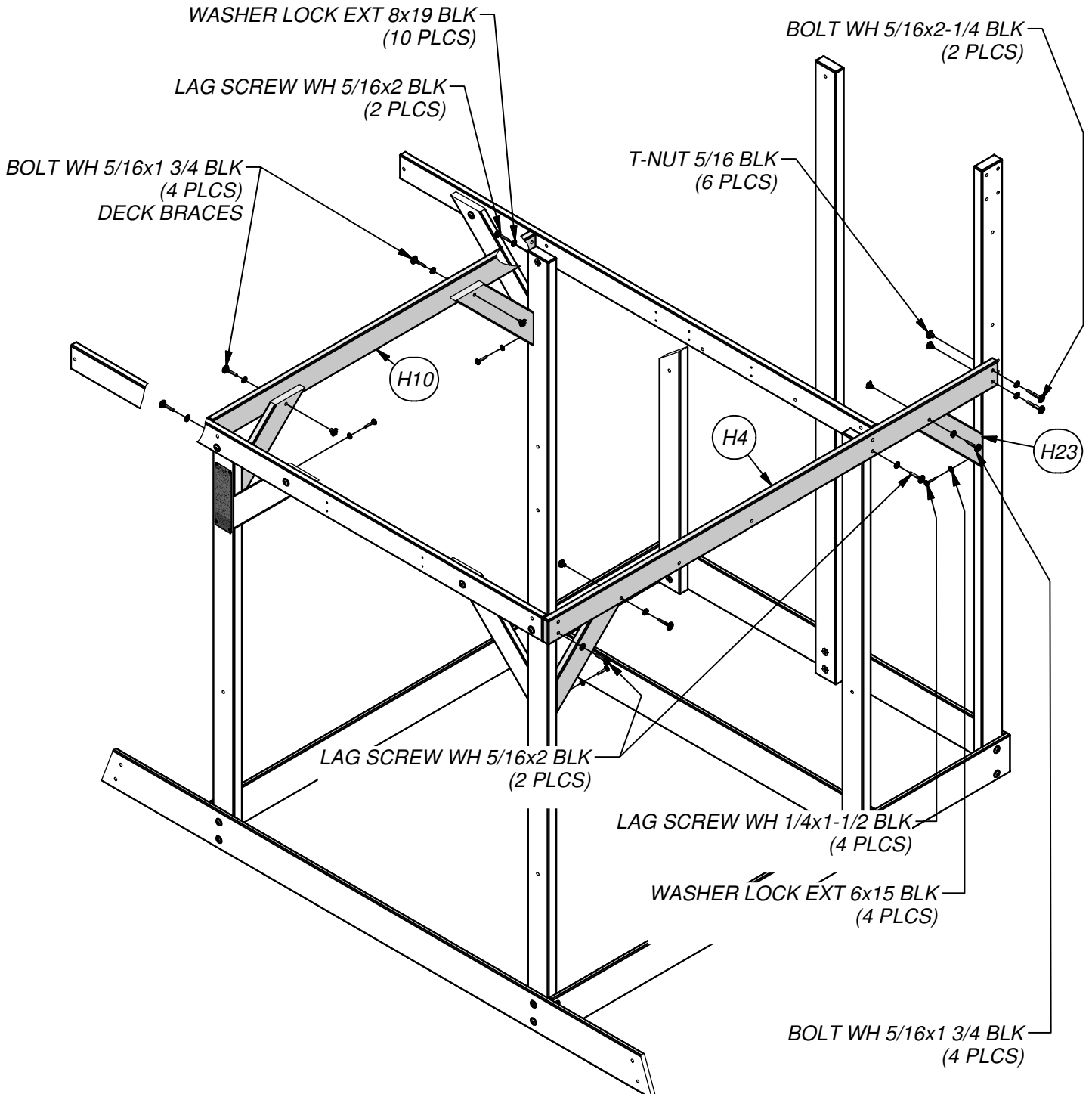
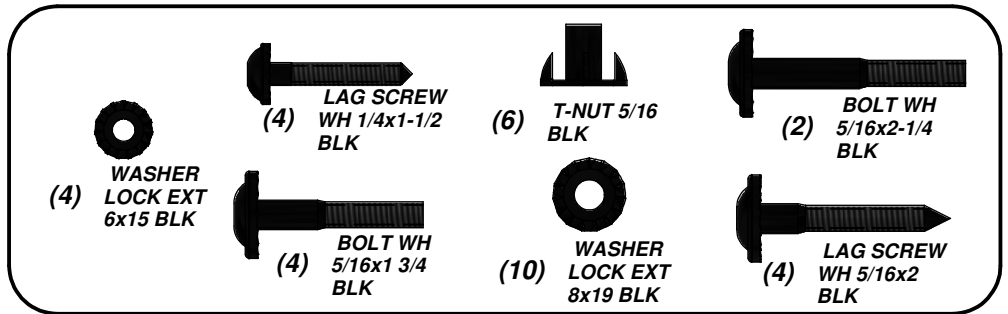



(2) J2 - FLOOR JOIST - W4L06068
1"x2 3/8"x52 1/2" (24x60x1334)

(1) - "A" REVISION TAG - A100314

STEP 9

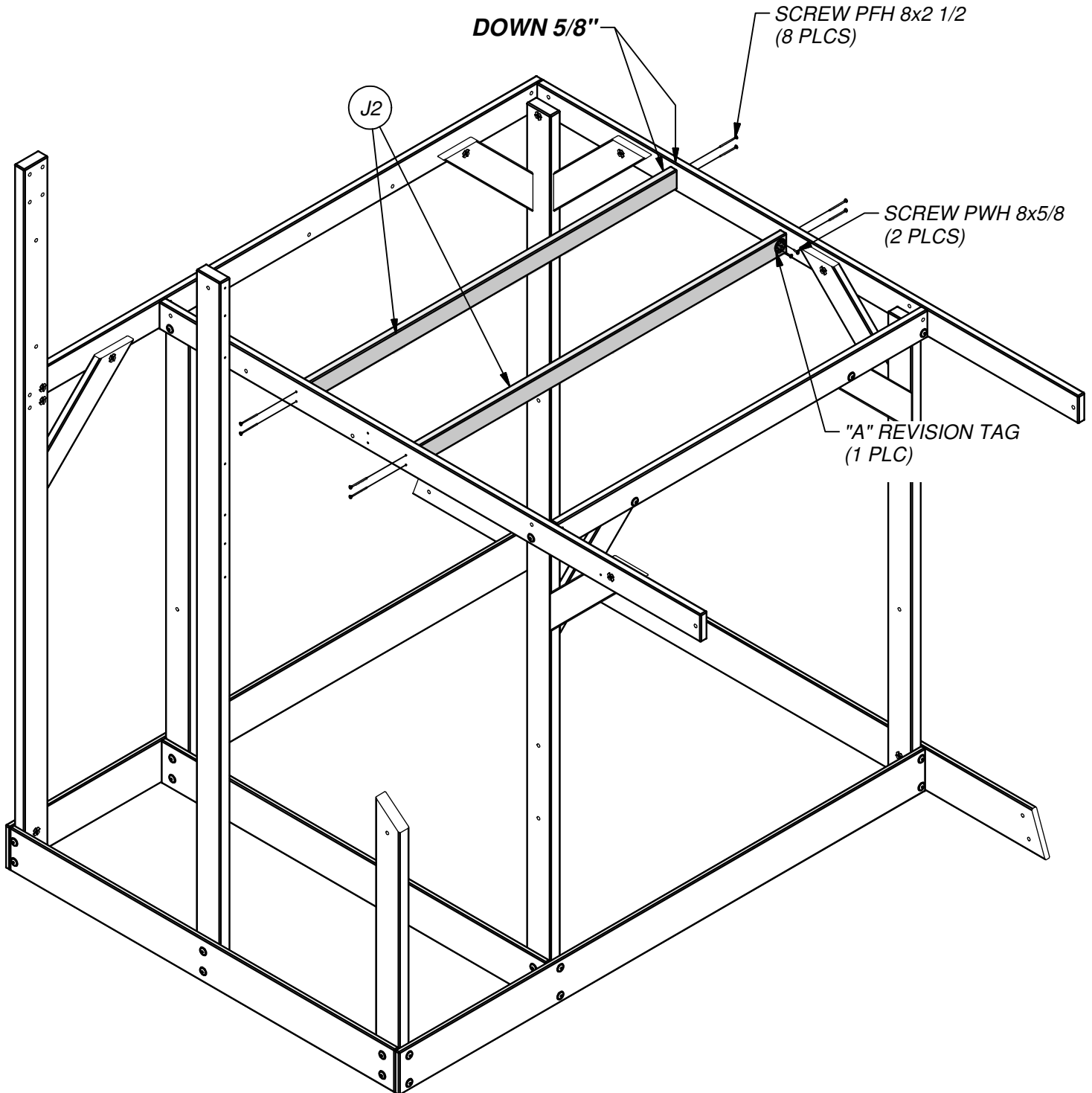
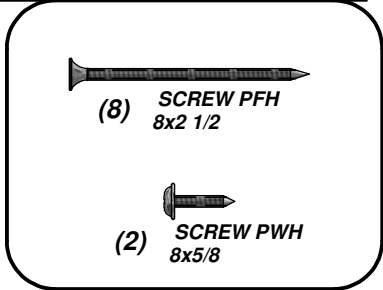

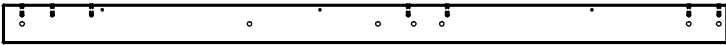

(1) **E4 - UPRIGHT - W4L06085**
1 3/8"x3 3/8"x63" (36x86x1600)

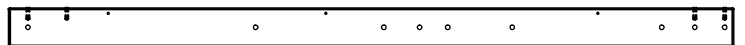

(1) **E3 - UPRIGHT - W4L06069**
1 3/8"x3 3/8"x63" (36x86x1600)

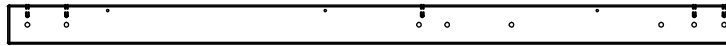

(1) **E6 - UPRIGHT - W4L06091**
1 3/8"x3 3/8"x63" (36x86x1600)

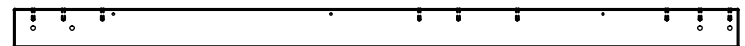

(1) **E5 - UPRIGHT - W4L06090**
1 3/8"x3 3/8"x63" (36x86x1600)

STEP 10

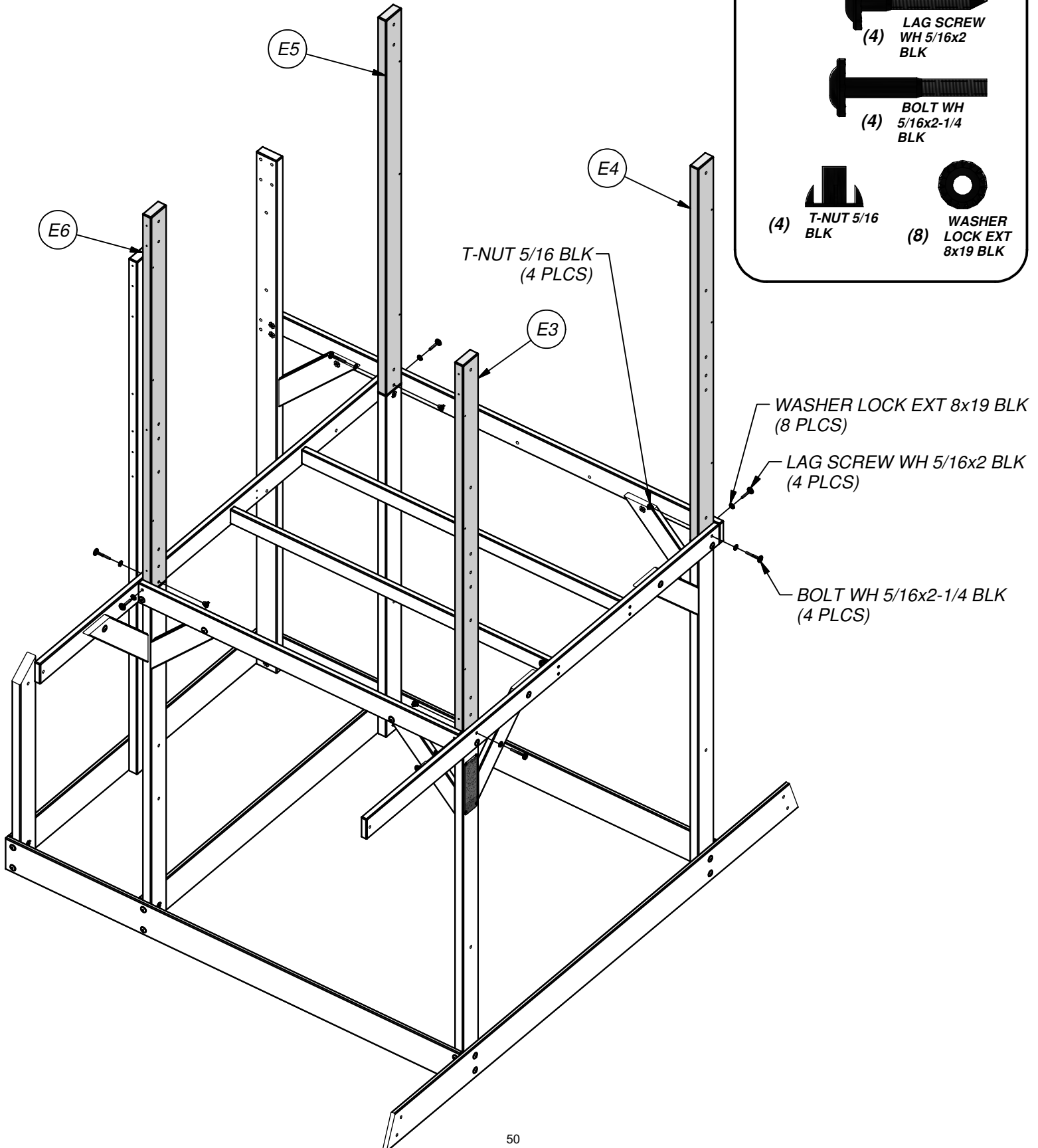



(1) T2 - SUPPORT BOARD - W4L06065
1"x1 3/8"x49 5/8" (24x34x1260)

STEP 11

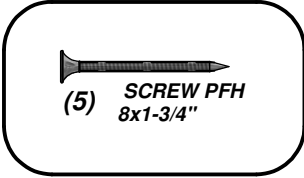
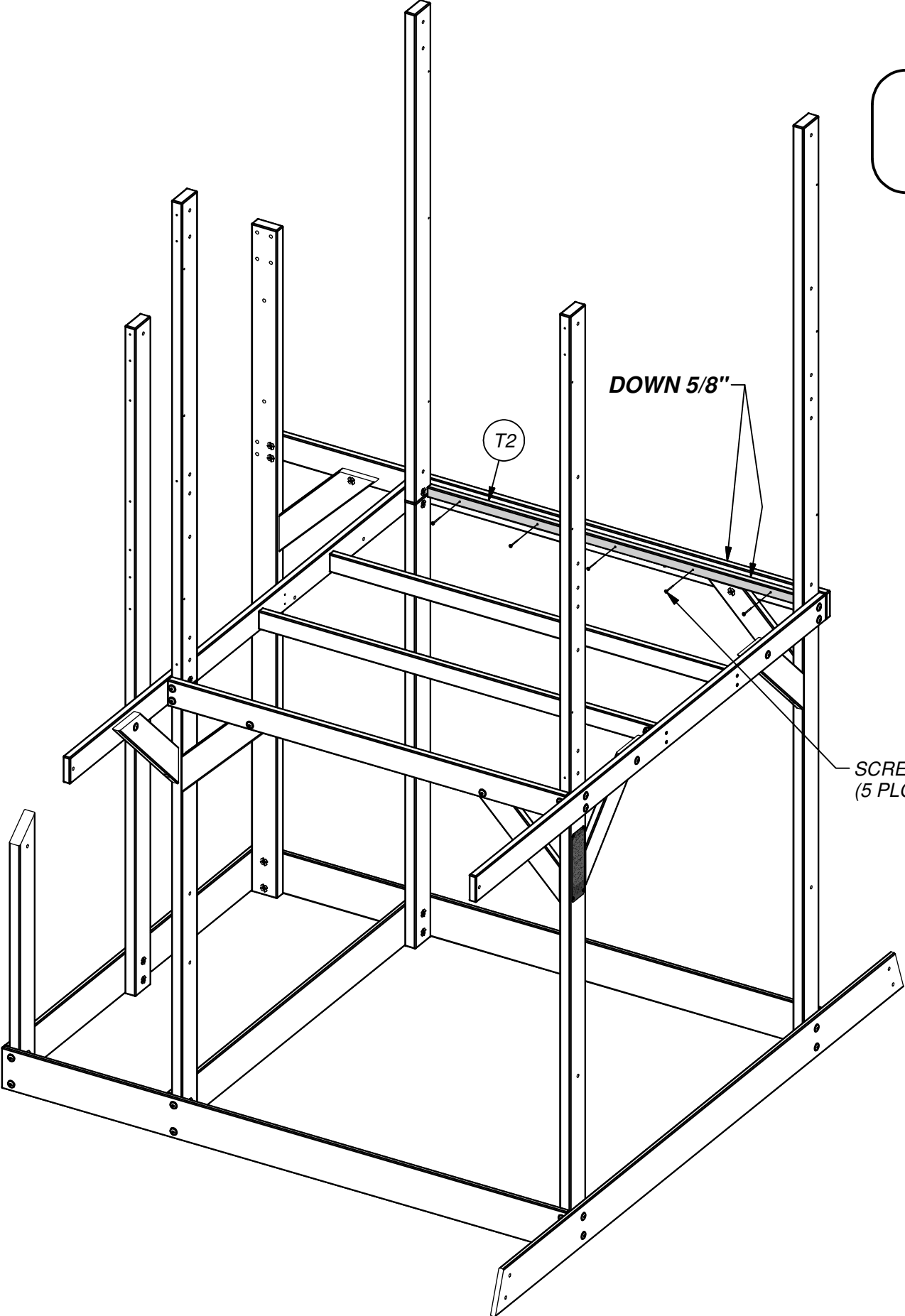

SCREW PFH 8x1-3/4"
(5 PLCS)

(1) T2 - SUPPORT BOARD - W4L06065
1"x1 3/8"x49 5/8" (24x34x1260)

(2) M27 - CORNER BOARD - W4L06147
5/8"x3 3/8"x50 3/8" (16x86x1280)

STEP 12

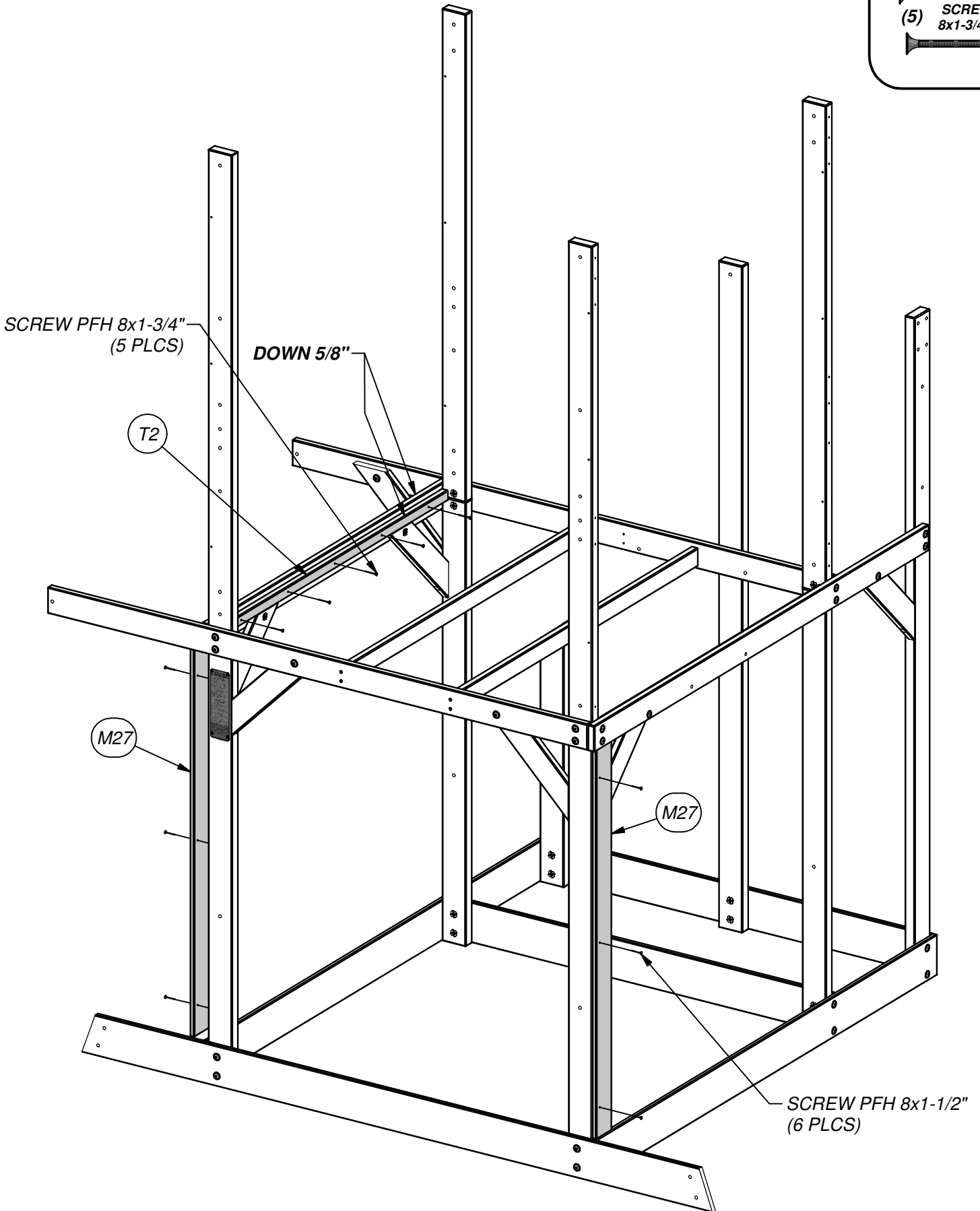
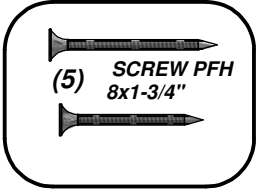



(1) T1 - SUPPORT BOARD - W4L06075
1"x1 3/8"x50" (24x34x1270)

STEP 13

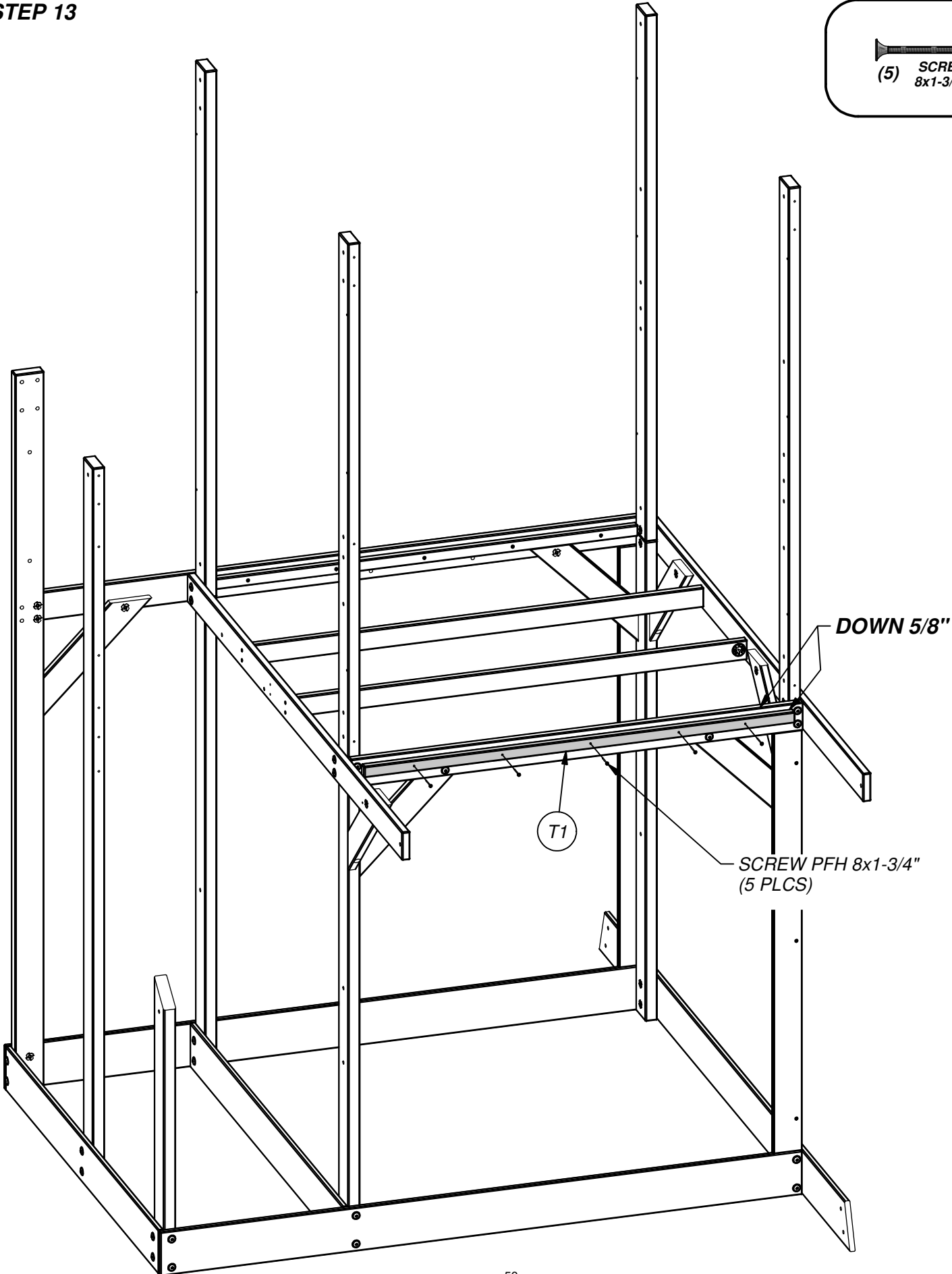
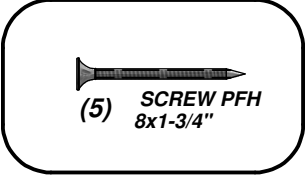

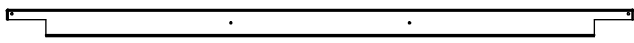

(2) **N1 - FLOOR BOARD - W4L06067**
5/8"x2 3/8"x54 1/2" (16x60x1384)



(14) **M6 - FLOOR BOARD - W4L06066**
5/8"x3 3/8"x54 1/2" (16x86x1384)

STEP 14

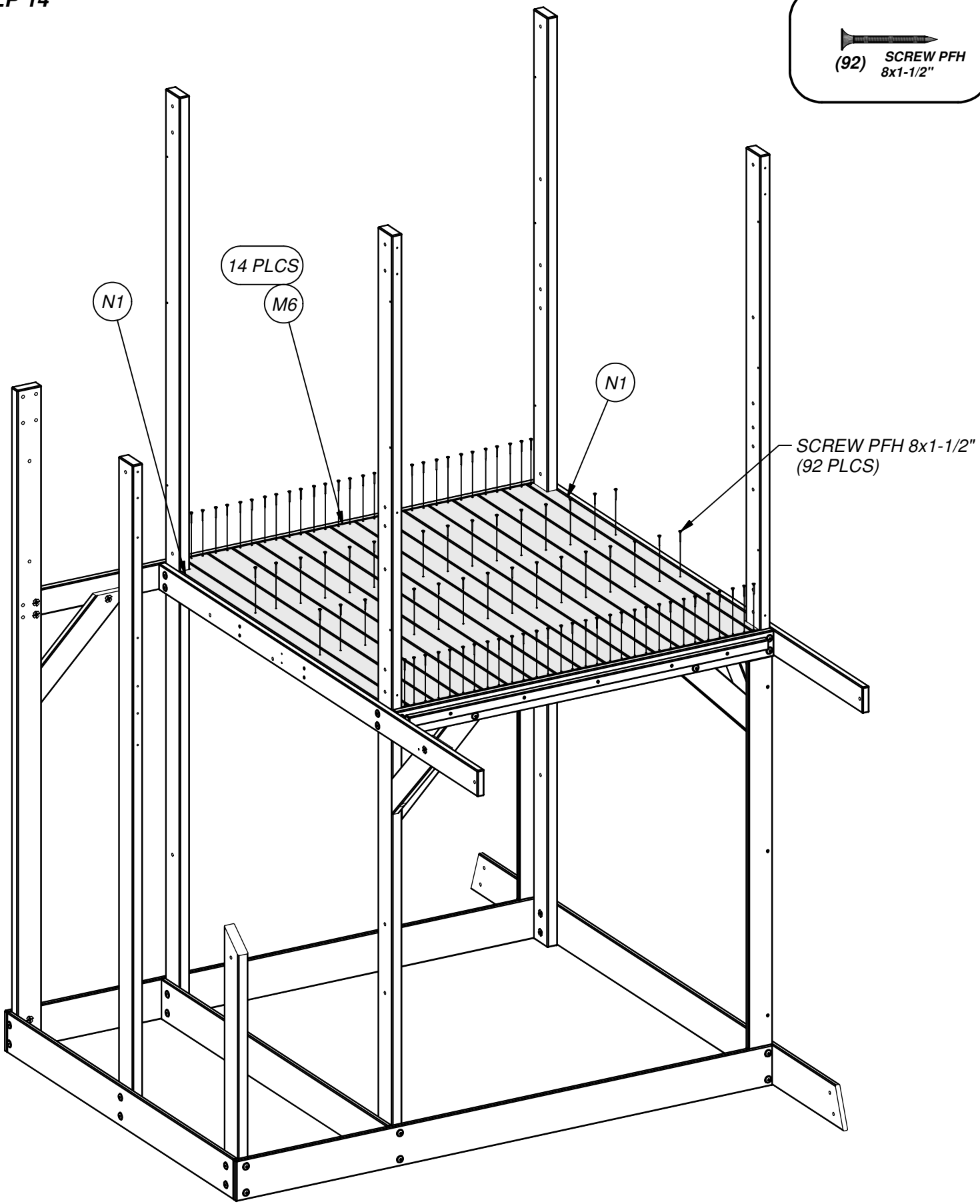
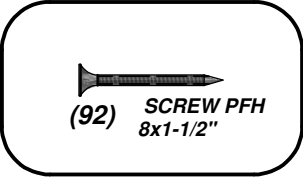



(1) **F4 - POST - W4L06093**
1 3/8"x2 3/8"x30 3/8" (36x60x772)

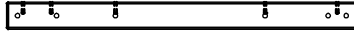

(1) **F2 - POST - W4L06070**
1 3/8"x2 3/8"x30 3/8" (36x60x772)

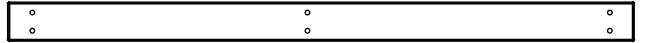

(1) **H8 - FLOOR SUPPORT - W4L06079**
1"x3 3/8"x54 3/8" (24x86x1382)

STEP 15

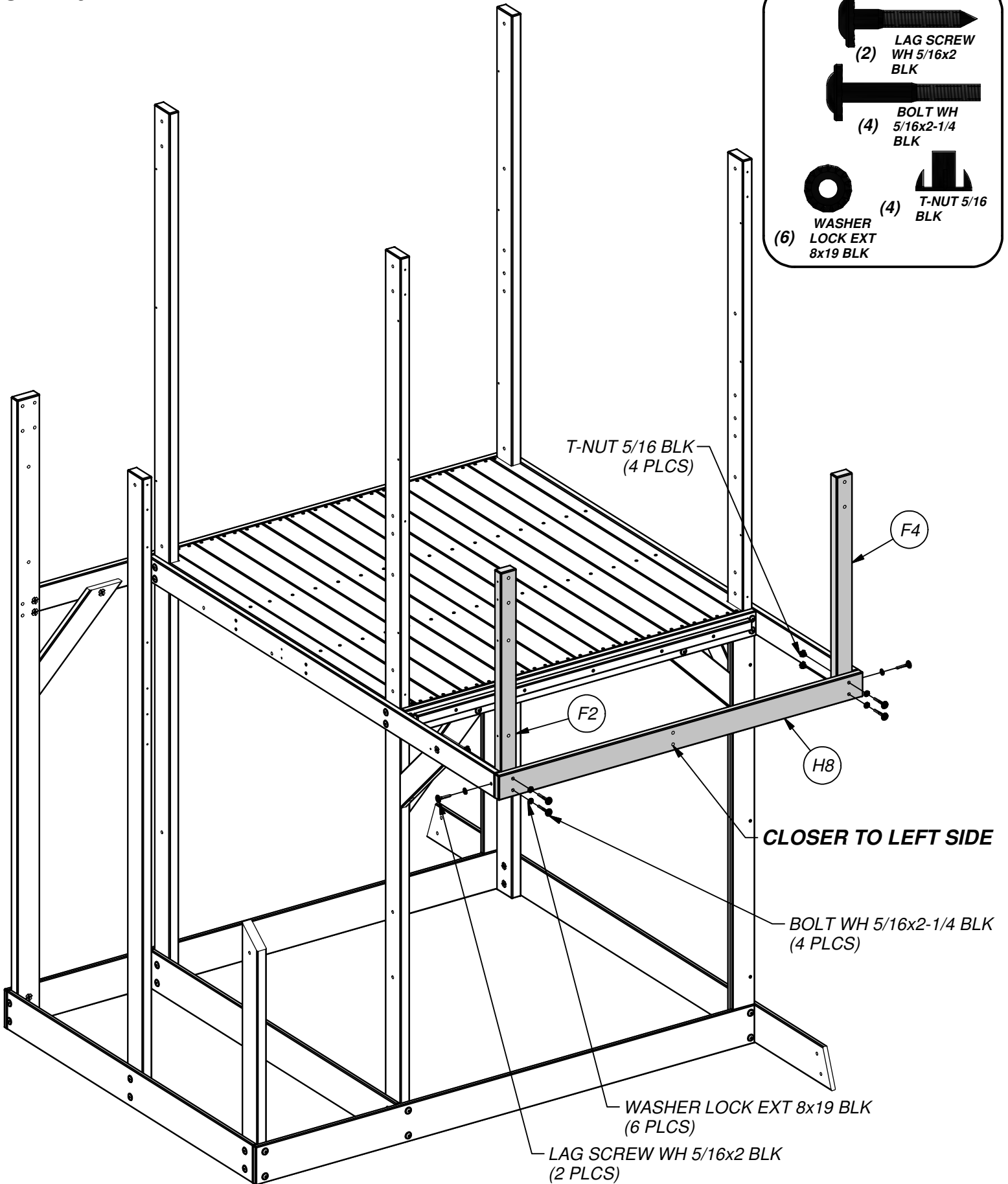
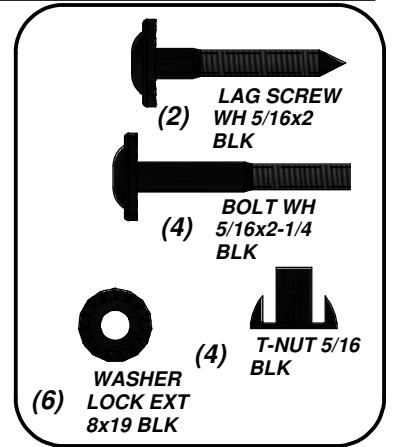



(1) F3 - POST - W4L06074
1 3/8"x2 3/8"x30 3/8" (36x60x772)

STEP 16

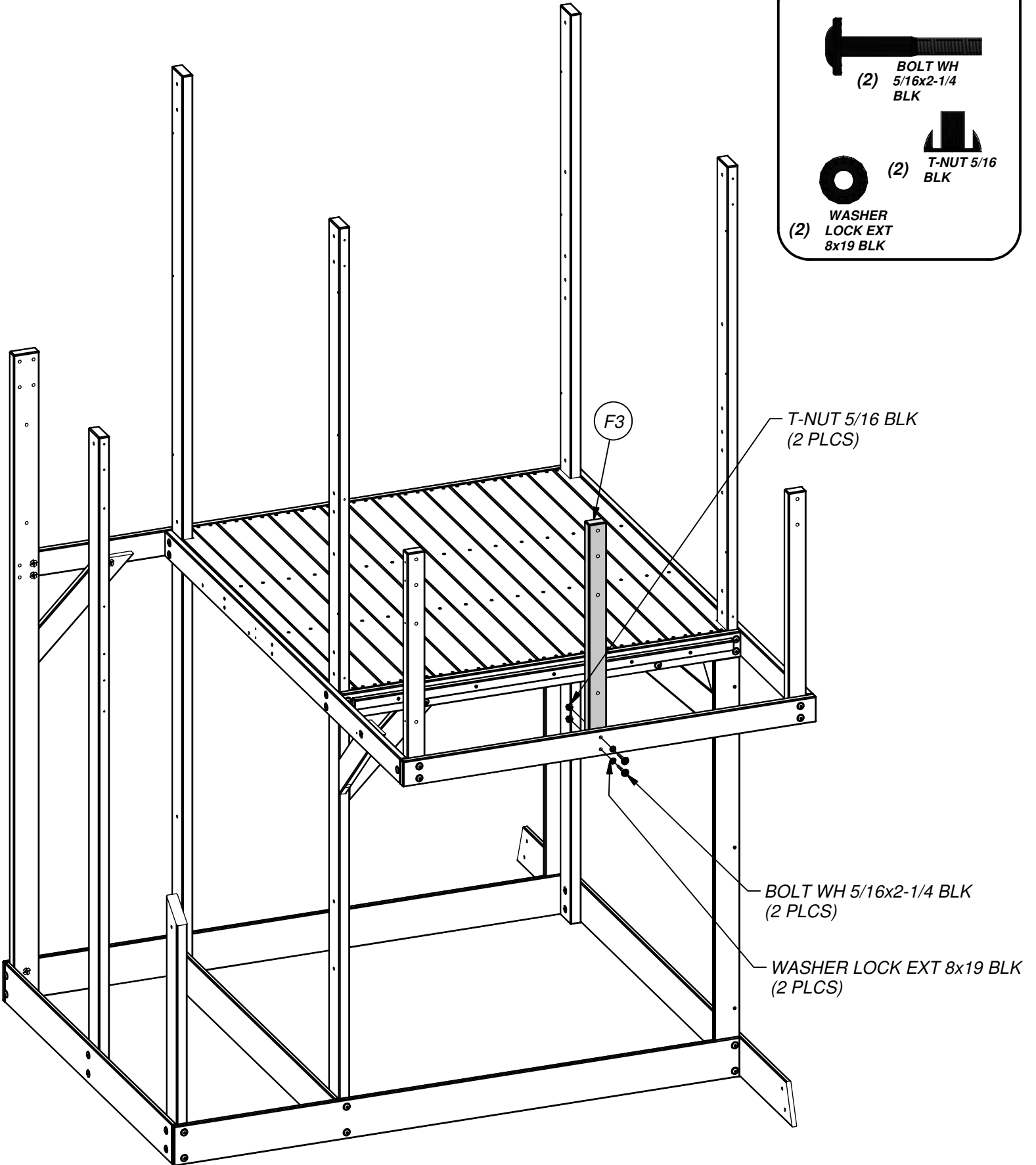
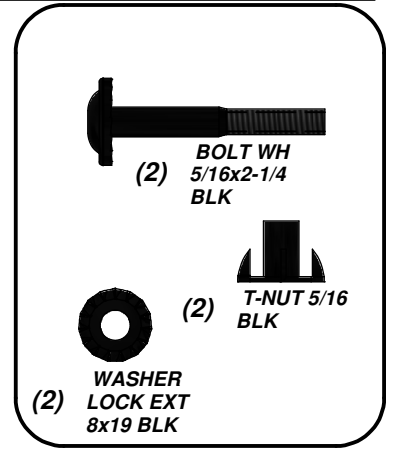

(1) **T4 - SUPPORT BOARD - W4L06077**
1"x1 3/8"x23 7/8" (24x34x606)

(1) **T5 - SUPPORT BOARD - W4L06076**
1"x1 3/8"x21 1/2" (24x34x546)

(3) **J9 - SUPPORT BOARD - W4L06064**
1"x2 3/8"x3" (24x60x76)

STEP 17

(10) **SCREW PFH**
8x1-3/4"

(2) **SCREW PFH**
8x2

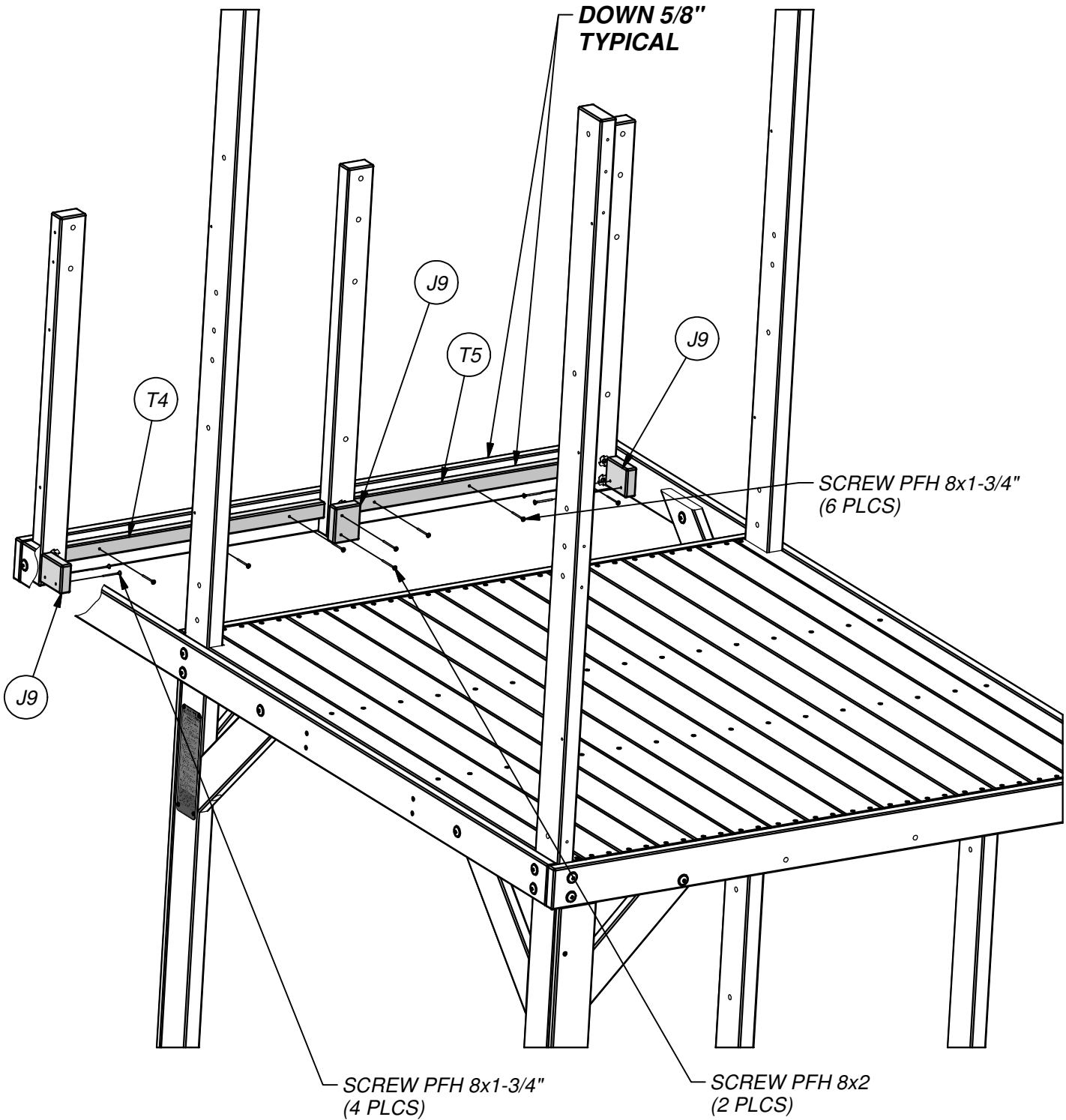

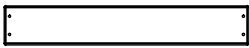

(7) **M21 - FLOOR BOARD - W4L06080**
5/8"x3 3/8"x21 1/4" (16x86x540)

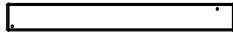

(1) **N3 - FLOOR BOARD - W4L06078**
5/8"x2 3/8"x19 3/4" (16x60x502)



(1) **M22 - FLOOR BOARD - W4L06081**
5/8"x3 3/8"x21 1/4" (16x86x540)

STEP 18

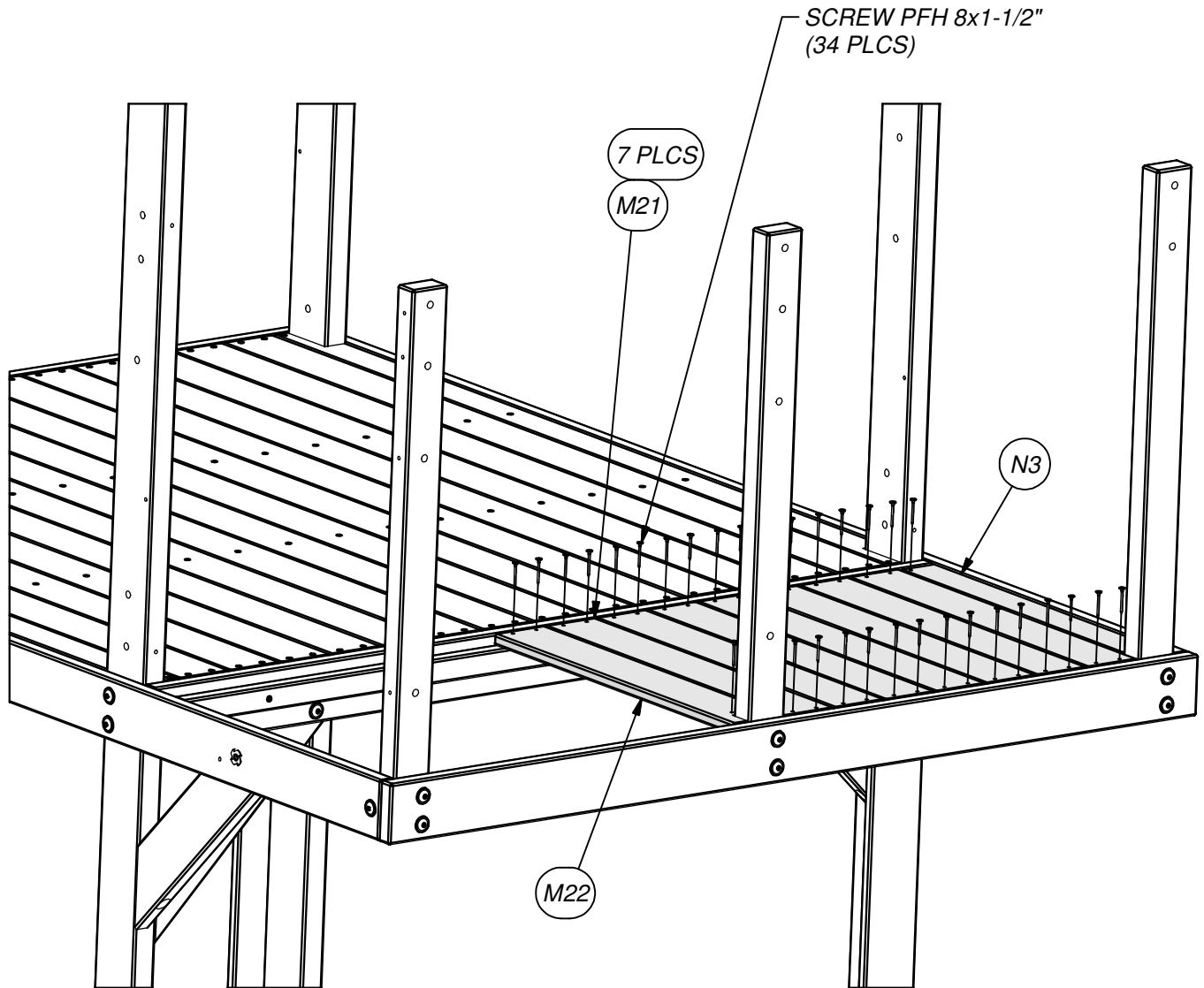

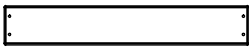

(6) M21 - FLOOR BOARD - W4L06080
5/8"x3 3/8"x21 1/4" (16x86x540)

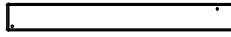

(1) N3 - FLOOR BOARD - W4L06078
5/8"x2 3/8"x19 3/4" (16x60x502)

STEP 19

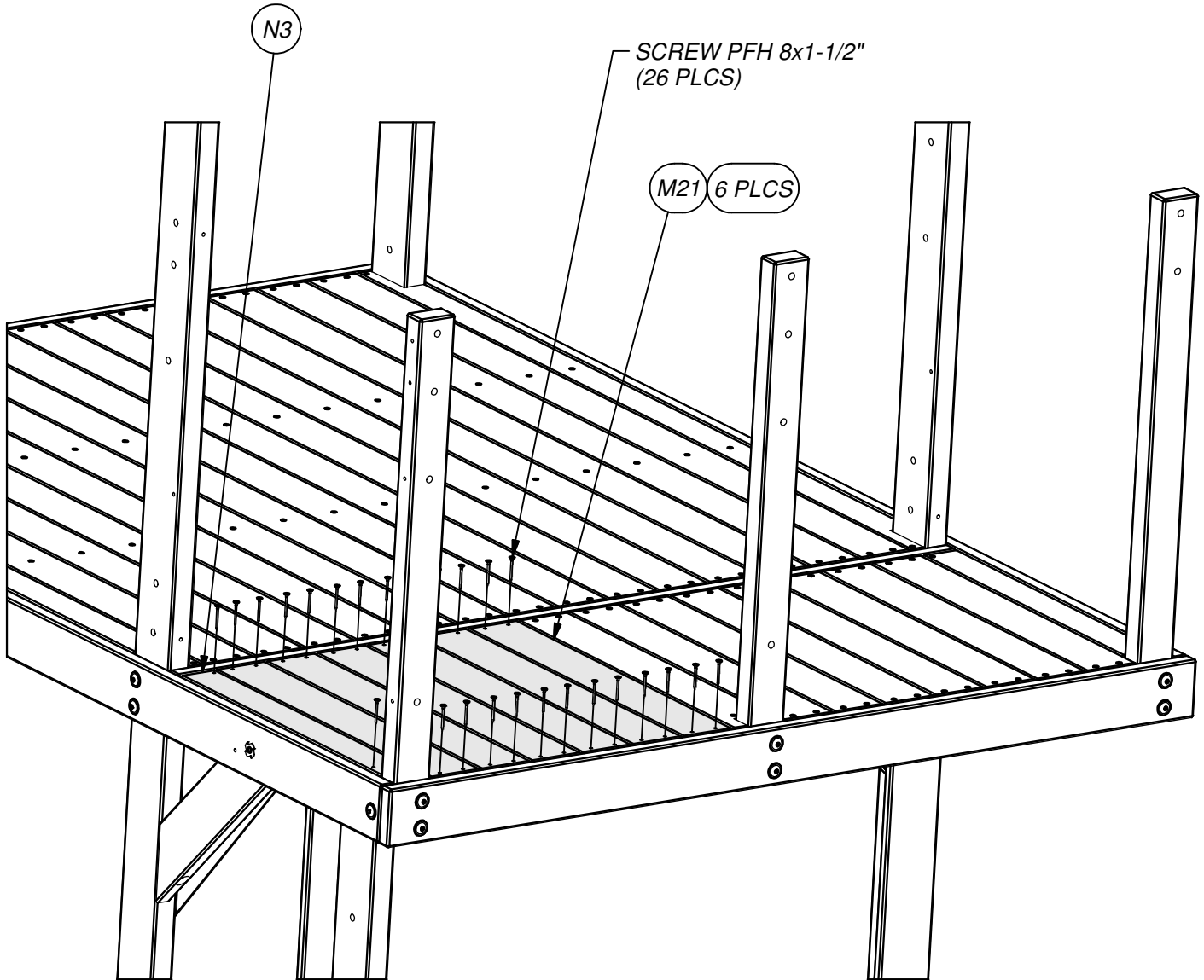
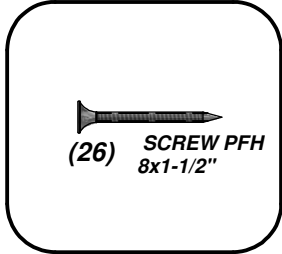

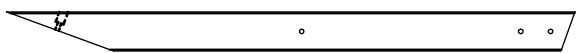

(2) **H86 - ANGLE BRACE - W4L06186**
1"x3 3/8"x49 3/8" (24x86x1254)

(1) **J10 - SUPPORT BOARD - W4L06194**
1"x2 3/8"x3" (24x60x76)

(1) **J9 - SUPPORT BOARD - W4L06064**
1"x2 3/8"x3" (24x60x76)

(1) **T8 - SUPPORT BOARD - W4L06119**
1"x1 3/8"x16 5/8" (24x34x423)

STEP 20

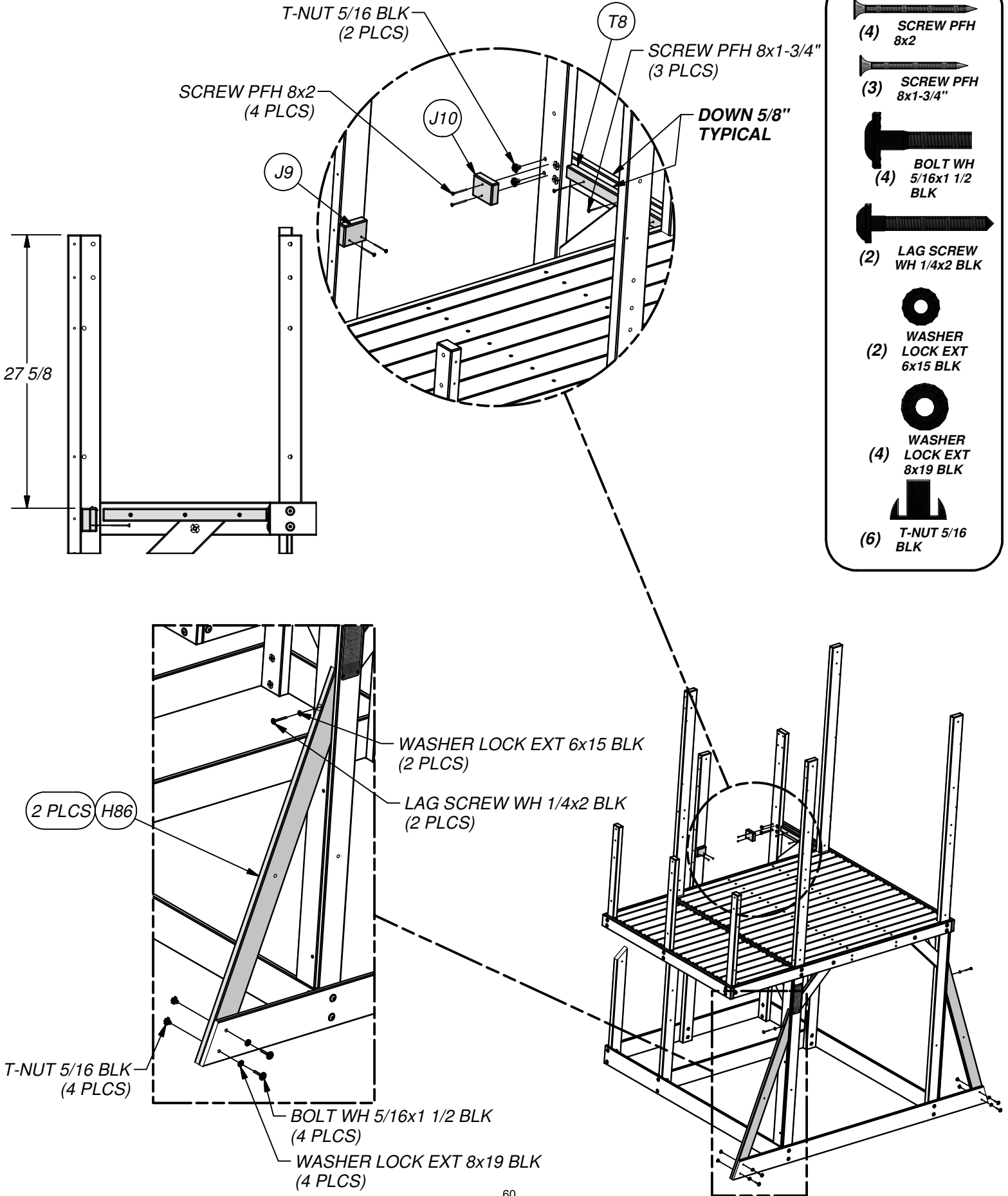



(1) E11 - UPRIGHT - W4L06127
 1 3/8"x3 3/8"x10 7/8" (36x86x275)

STEP 21

(1) WASHER LOCK EXT 8x19 BLK

(1) T-NUT 5/16 BLK

(1) BOLT WH 5/16x2-1/4 BLK

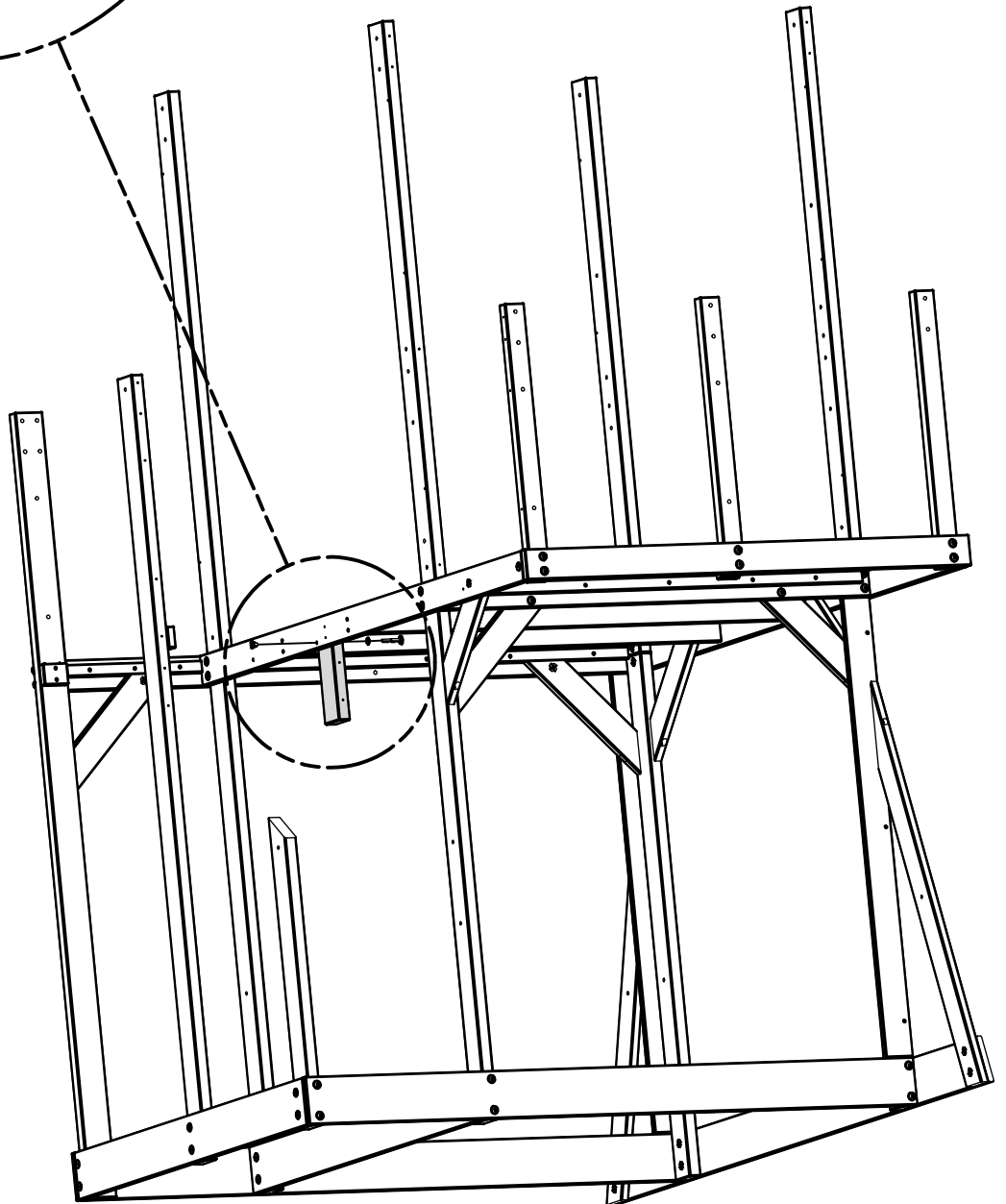
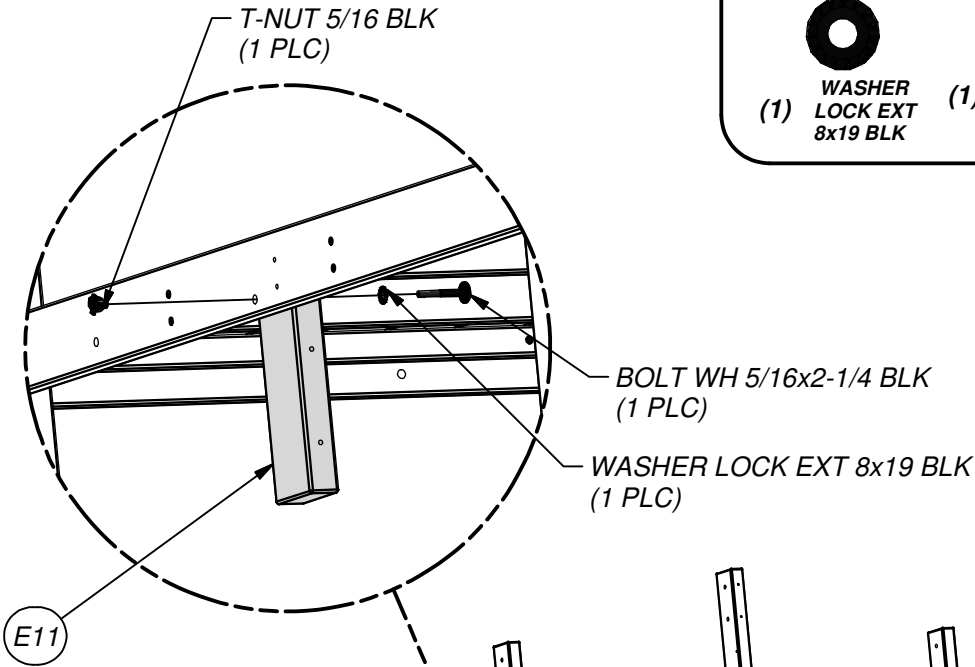



(2) **F5 - POST - W4L06323**
 1 3/8"x2 3/8"x30 3/8" (36x60x772)

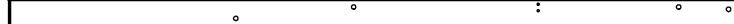

(1) **H12 - FLOOR SUPPORT - W4L06321**
 1"x3 3/8"x63 3/4" (24x86x1618)

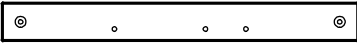

(1) **H15 - FLOOR SUPPORT - W4L06327**
 1"x3 3/8"x31" (24x86x788)

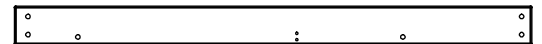

(1) **H14 - FLOOR SUPPORT - W4L06193**
 1"x3 3/8"x45" (24x86x1142)

STEP 22

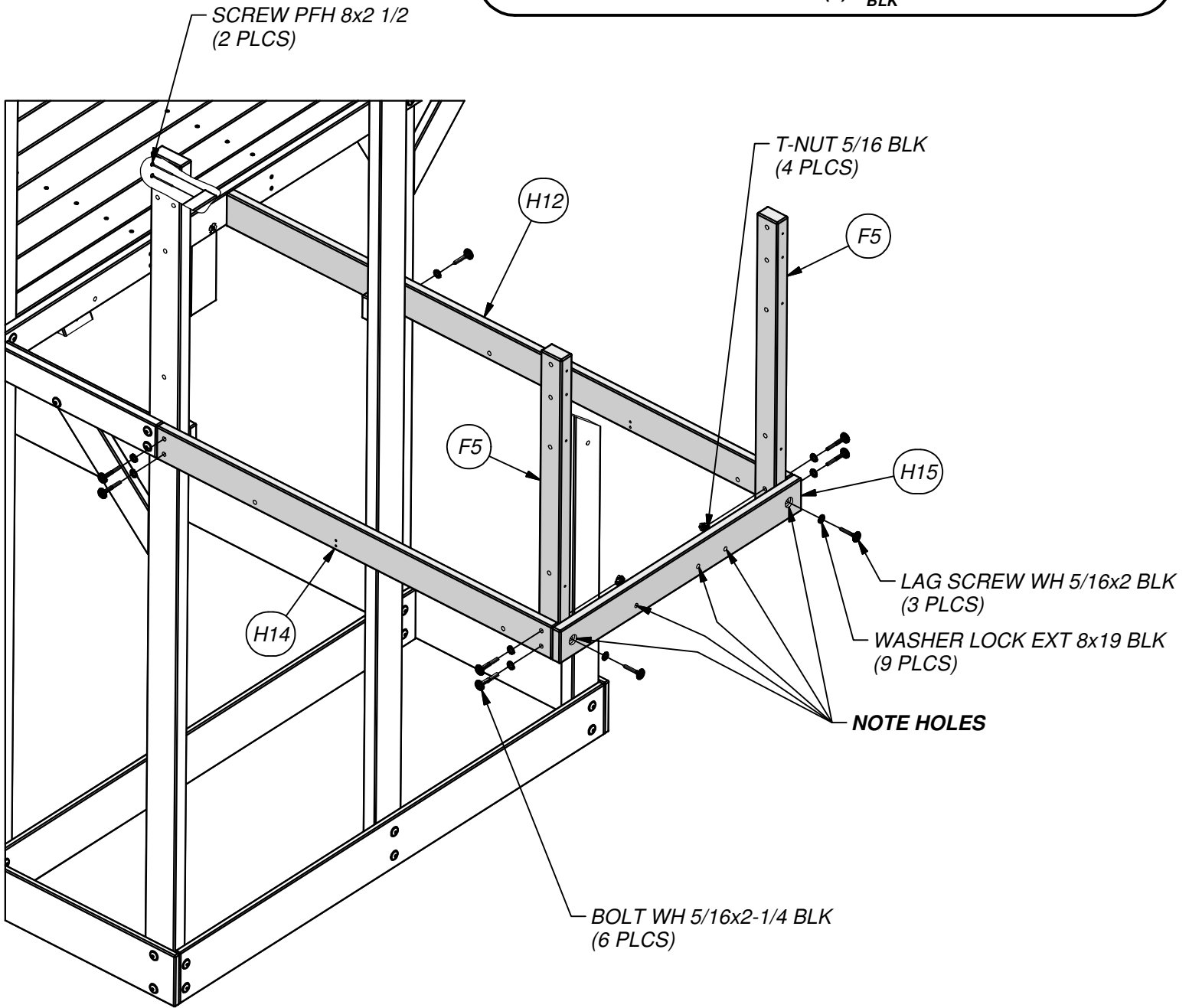
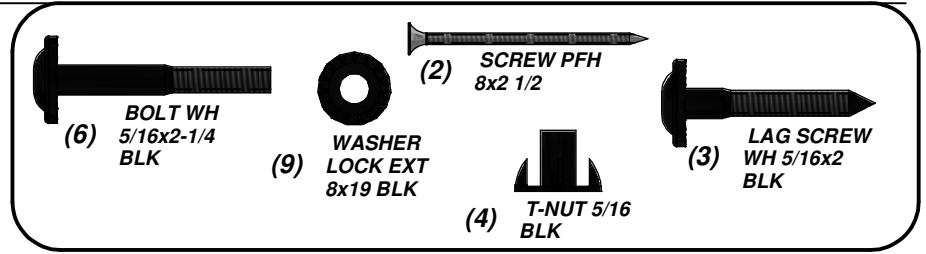

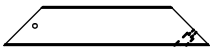

(2) **H23 - DECK BRACE - W4L06179**
1"x3 3/8"x17 7/8" (24x86x453)

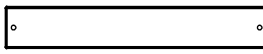

(1) **L1 - SUPPORT BOARD - W4L06128**
5/8"x3 5/8"x22 3/4" (16x92x579)

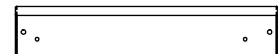

(1) **Q1 - SUPPORT BOARD - W4L06129**
1"x4 3/8"x22 3/4" (24x112x579)

STEP 23

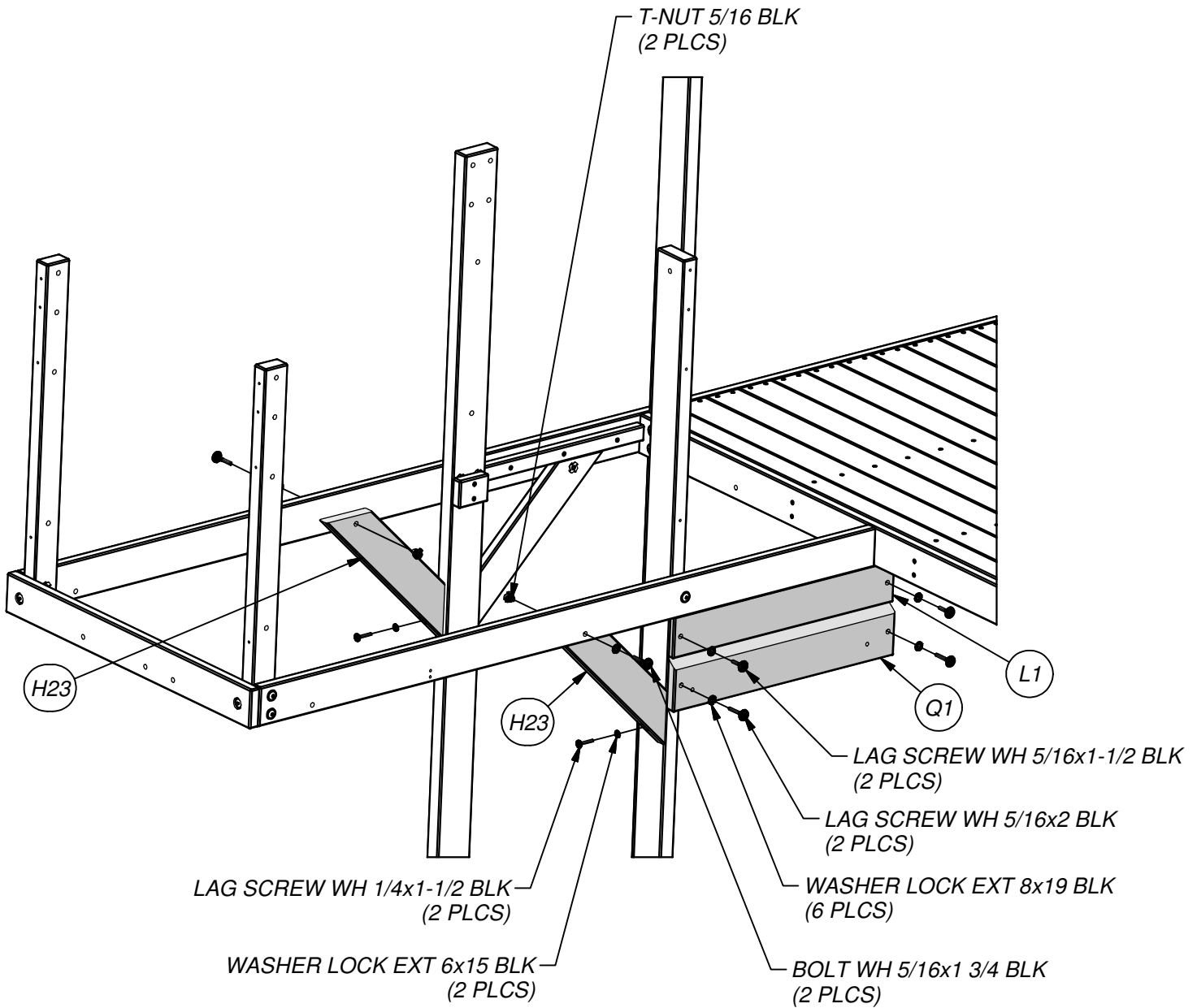
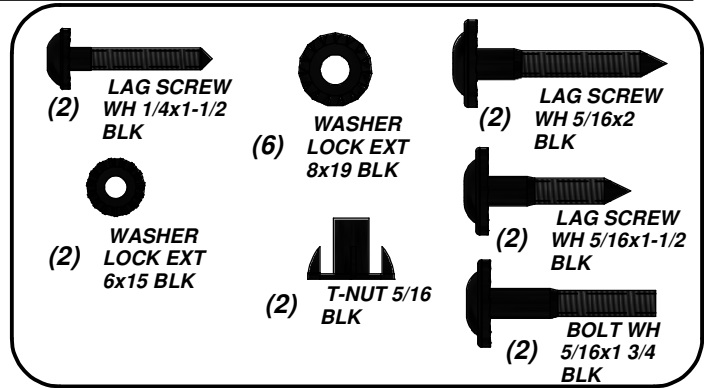

(2) T12 - SUPPORT BOARD - W4L06329
1" x 1 3/8" x 40 1/2" (24x34x1029)

(1) E13 - FLOOR JOIST - W4L06320
1 3/8" x 3 3/8" x 63 3/4" (36x86x1618)

(2) - L BRACKET BLK - A4M00615
2.5x38x50x55

(2) F6 - FLOOR JOIST - W4L06351
1 3/8" x 2 3/4" x 13 7/8" (36x70x352)

(1) T8 - SUPPORT BOARD - W4L06119
1" x 1 3/8" x 16 5/8" (24x34x423)

(2) J9 - SUPPORT BOARD - W4L06064
1" x 2 3/8" x 3" (24x60x76)

STEP 24

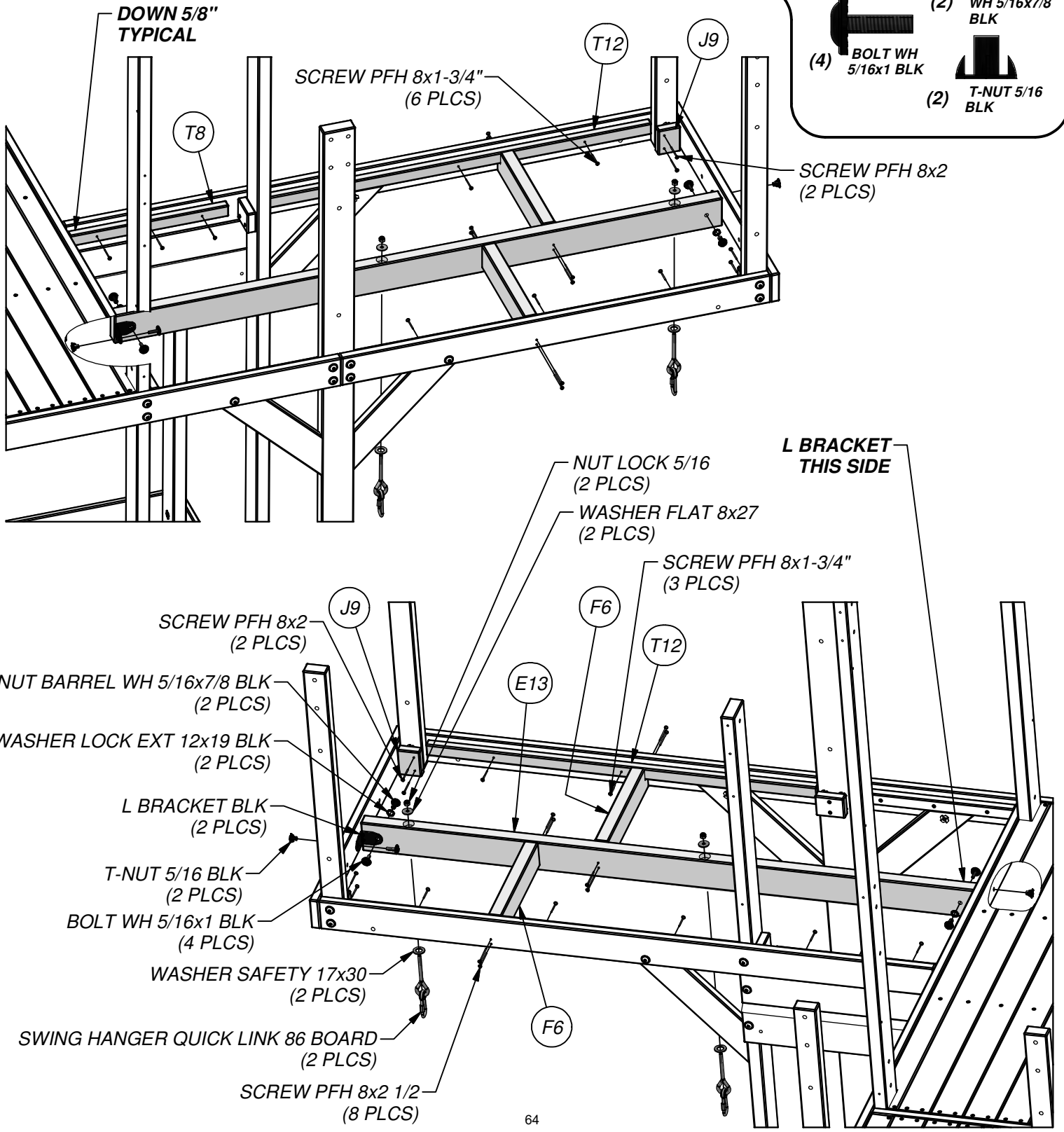
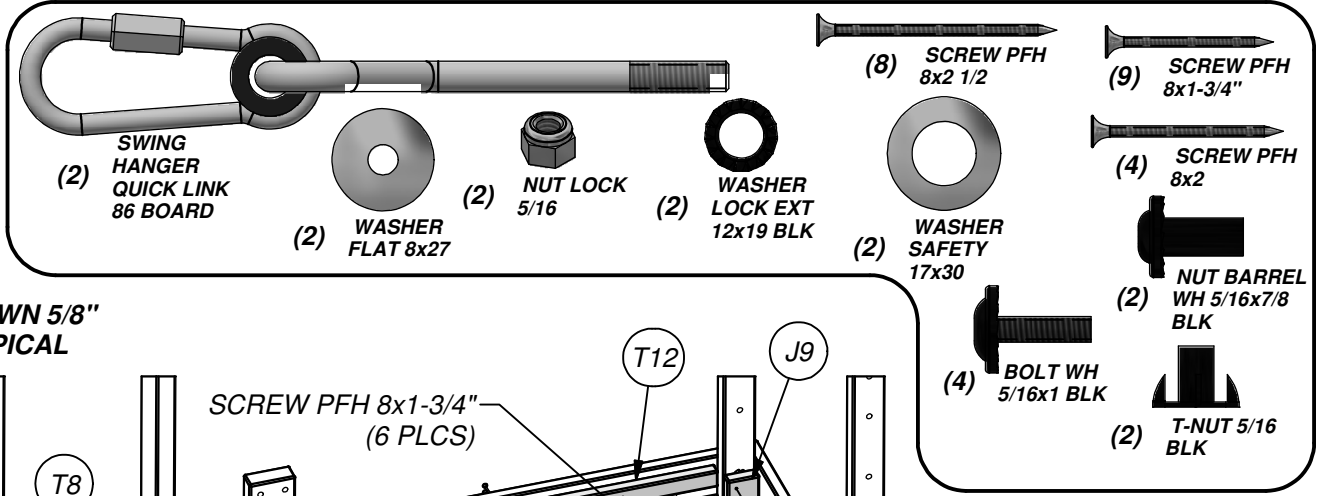



(17) **M15 - FLOOR BOARD - W4L06120**
5/8"x3 3/8"x29 1/8" (16x86x740)

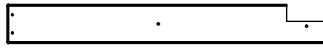

(1) **M16 - FLOOR BOARD - W4L06130**
5/8"x3 3/8"x27 3/4" (16x86x704)



(1) **N5 - FLOOR BOARD - W4L06328**
5/8"x2 3/8"x26 1/4" (16x60x668)

STEP 25

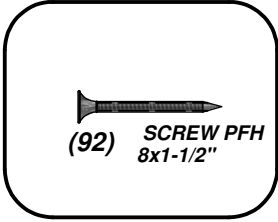

(92) **SCREW PFH**
8x1-1/2"

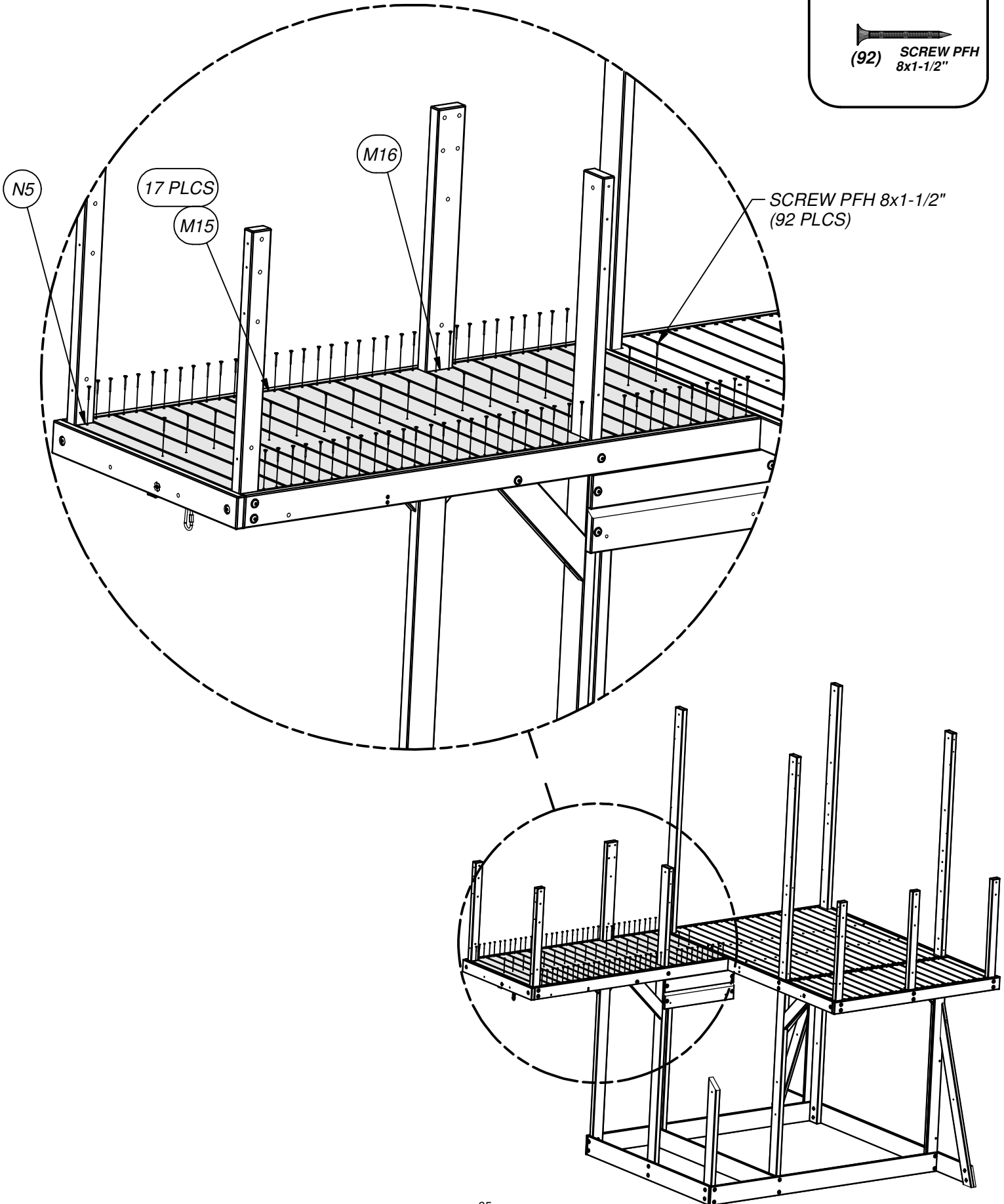

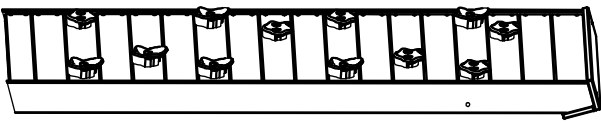

ROCKWALL ASSEMBLY



(1) K15 - ARCHED RAIL - W4L06326
5/8"x5 1/4"x30 3/8" (16x134x772)

(2) - METAL DECK BRACE 380 C/C - A4M00630



(2) - HAND GRIP METAL BLACK 381 c/c - A4M00613

STEP 26

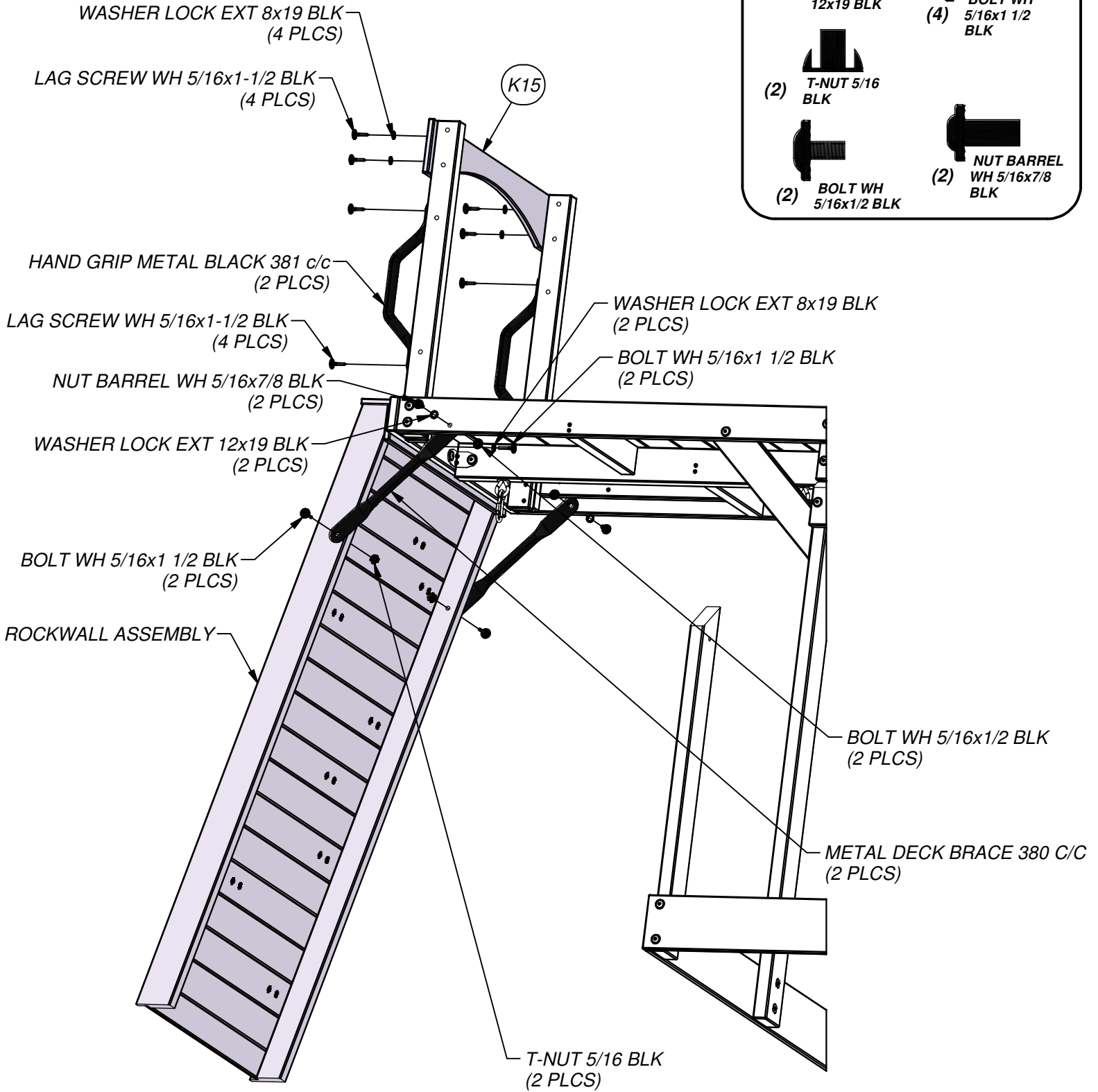
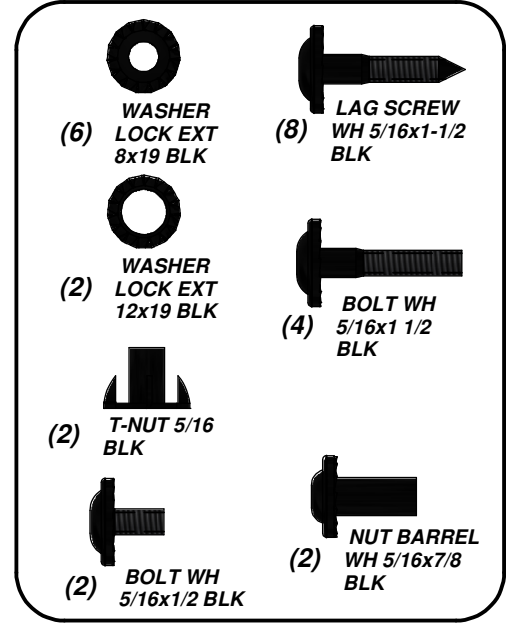

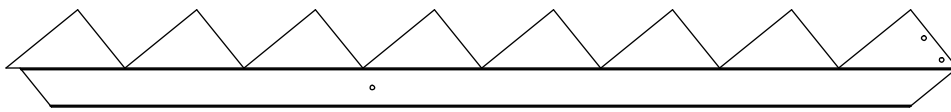

(1) **SR1 - STAIR RAIL - W2A01863**
1"x8 3/8"x82 5/8" (24x214x2099)

STEP 27

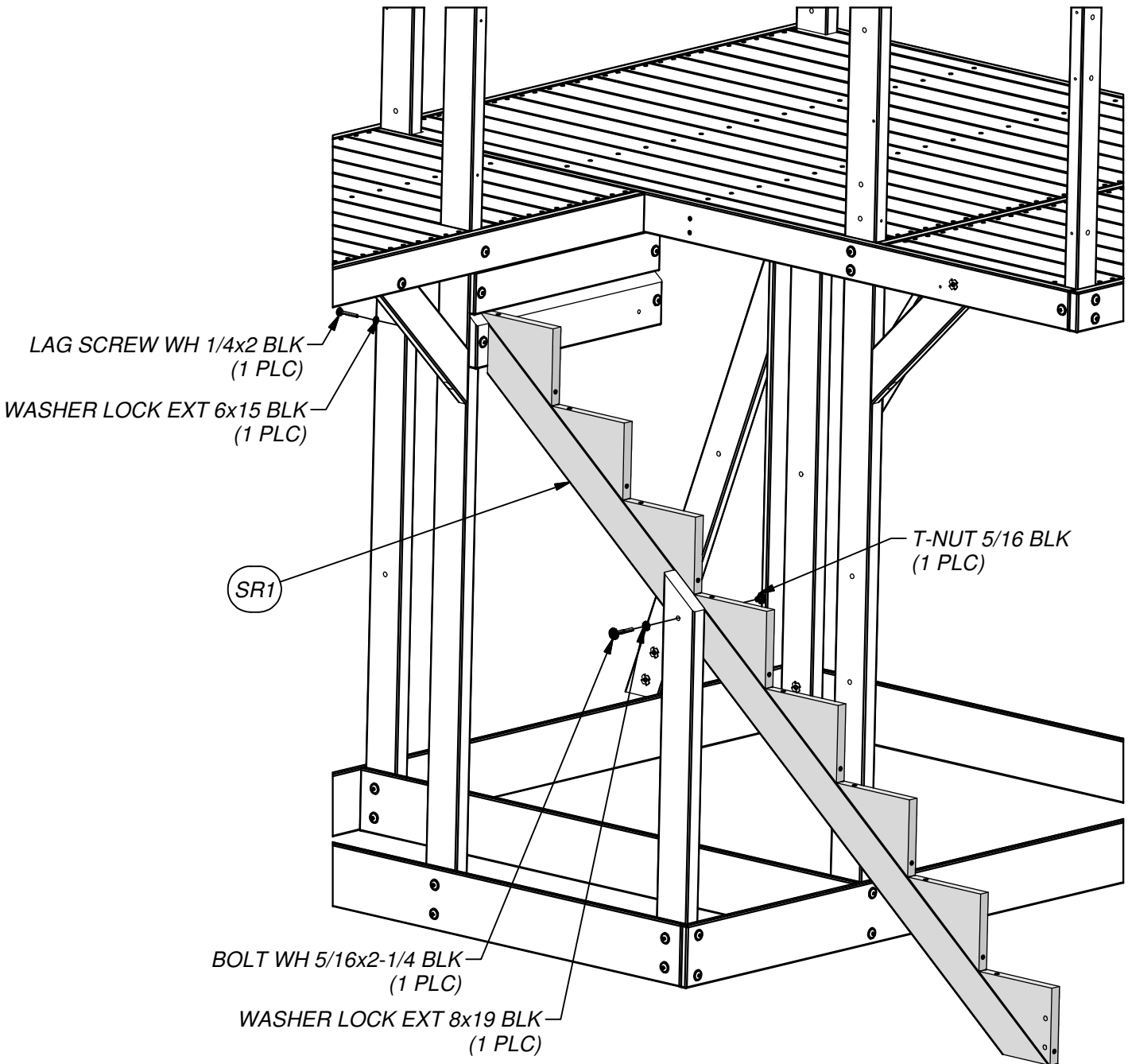
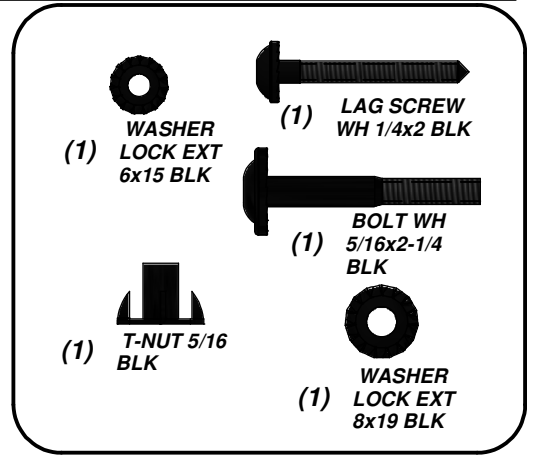



(1) **H13 - WALL SPACER - W4L06126**
 1"x3 3/8"x3 3/8" (24x86x86)

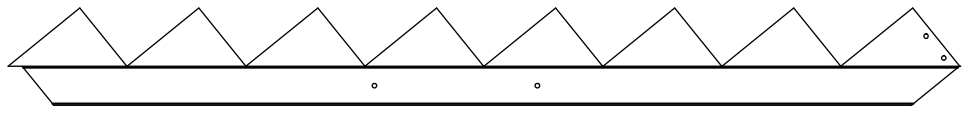

(1) **SR2 - STAIR RAIL - W2A01868**
 1"x8 3/8"x82 5/8" (24x214x2099)

STEP 28

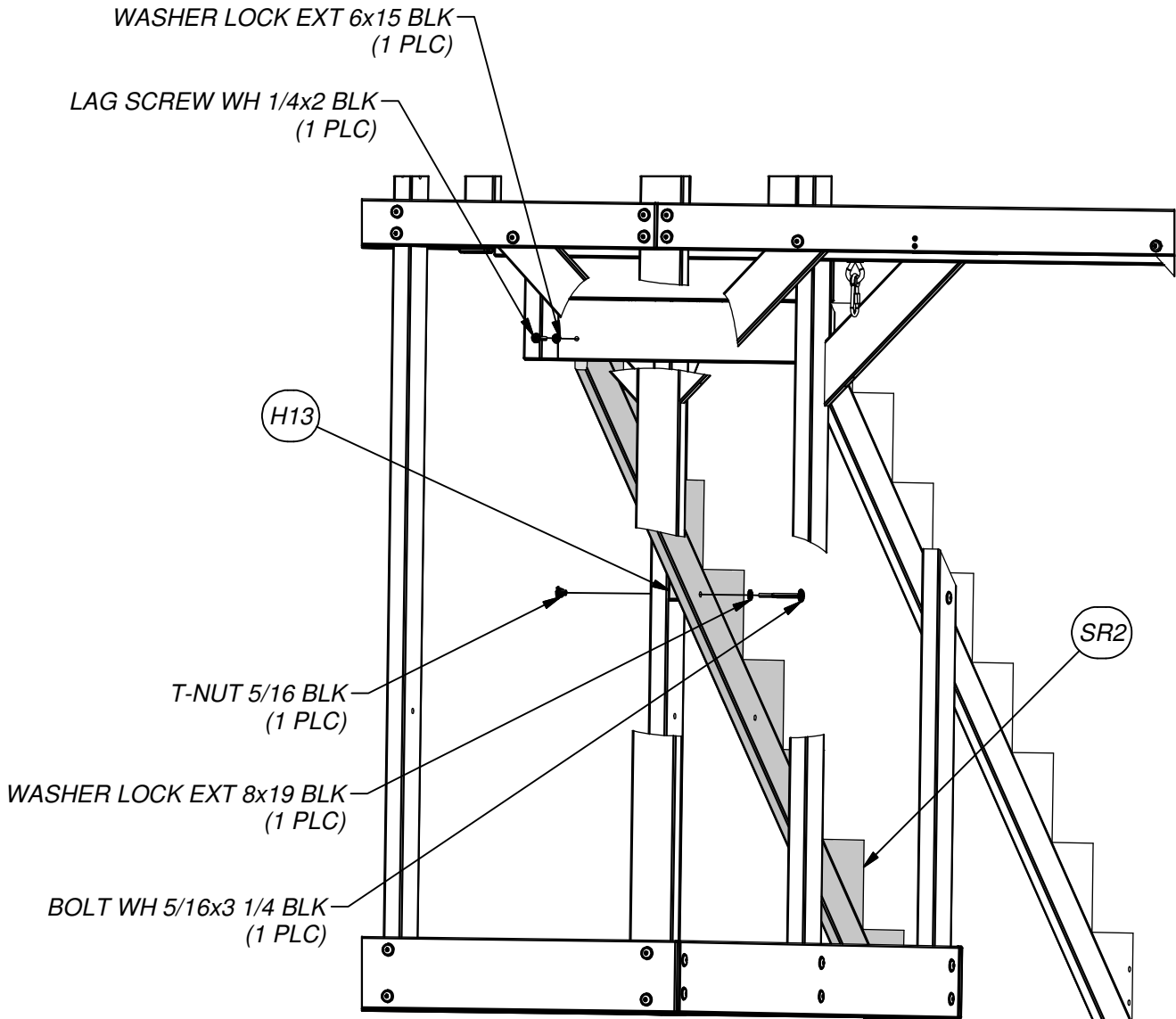
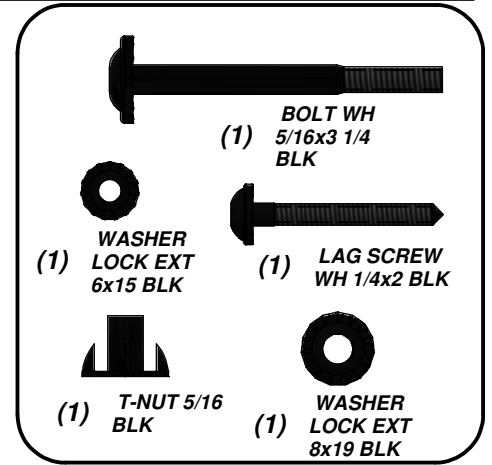

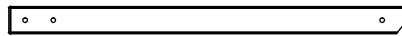

F1 - UPRIGHT - W4L06131
 (2) 1 3/8"x2 3/8"x34 7/8" (36x60x887)

STEP 29

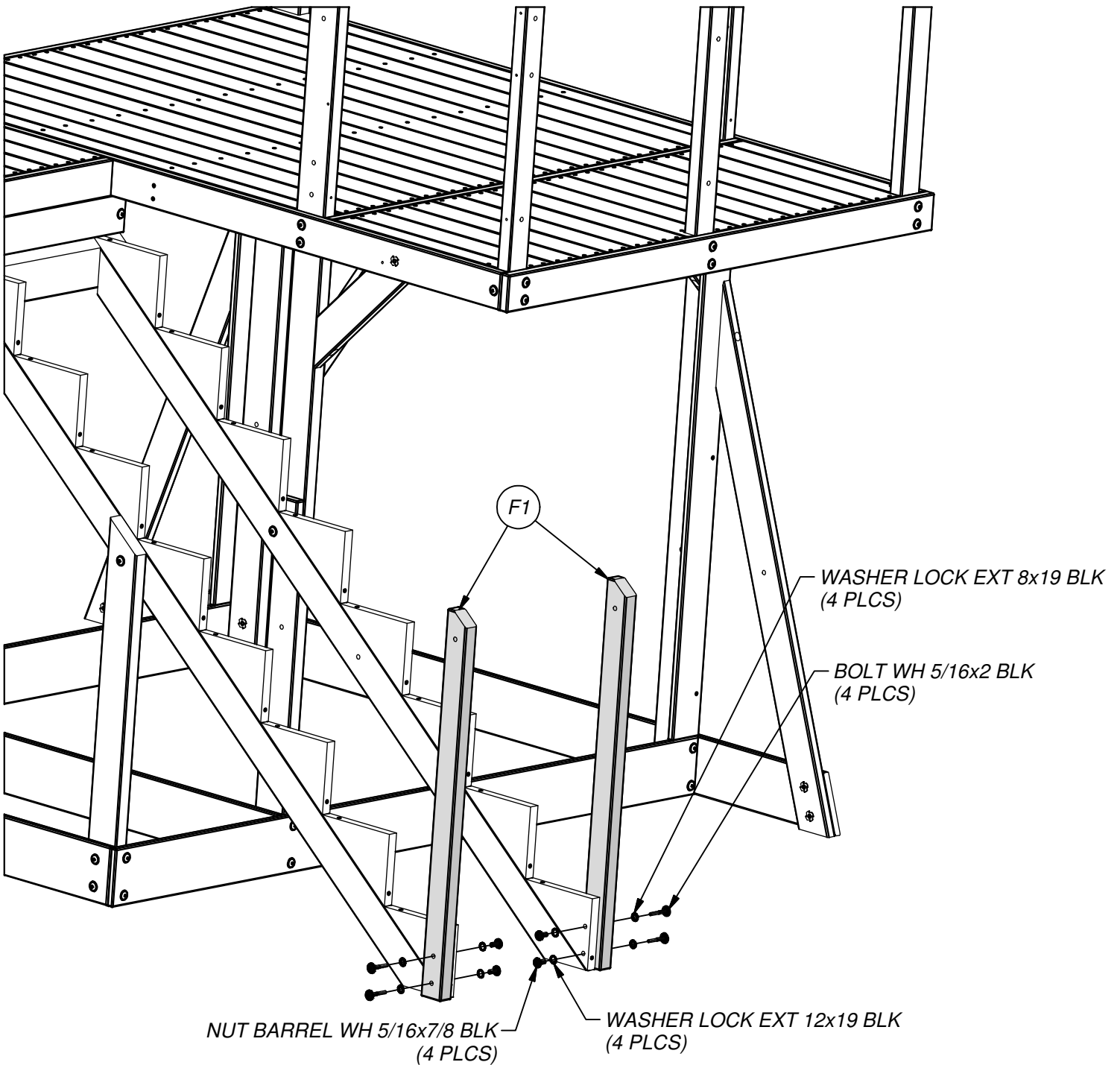
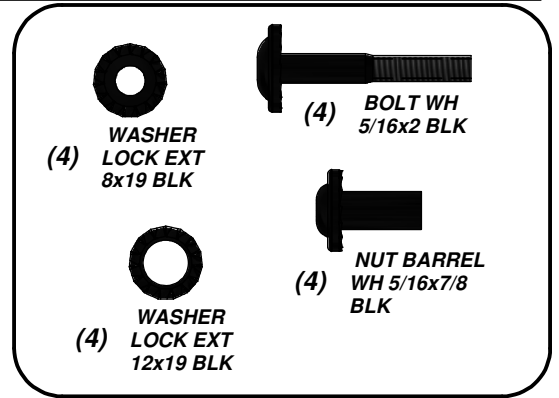

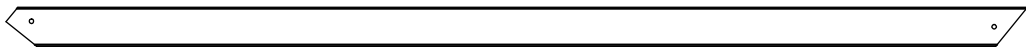

(1) **H1 - HANDRAIL - W4L06132**
1"x3 3/8"x88 3/4" (24x86x2253)

STEP 30

(2) **BOLT WH**
5/16x2-1/4
BLK

(2) **WASHER**
LOCK EXT
8x19 BLK

(2) **T-NUT 5/16**
BLK

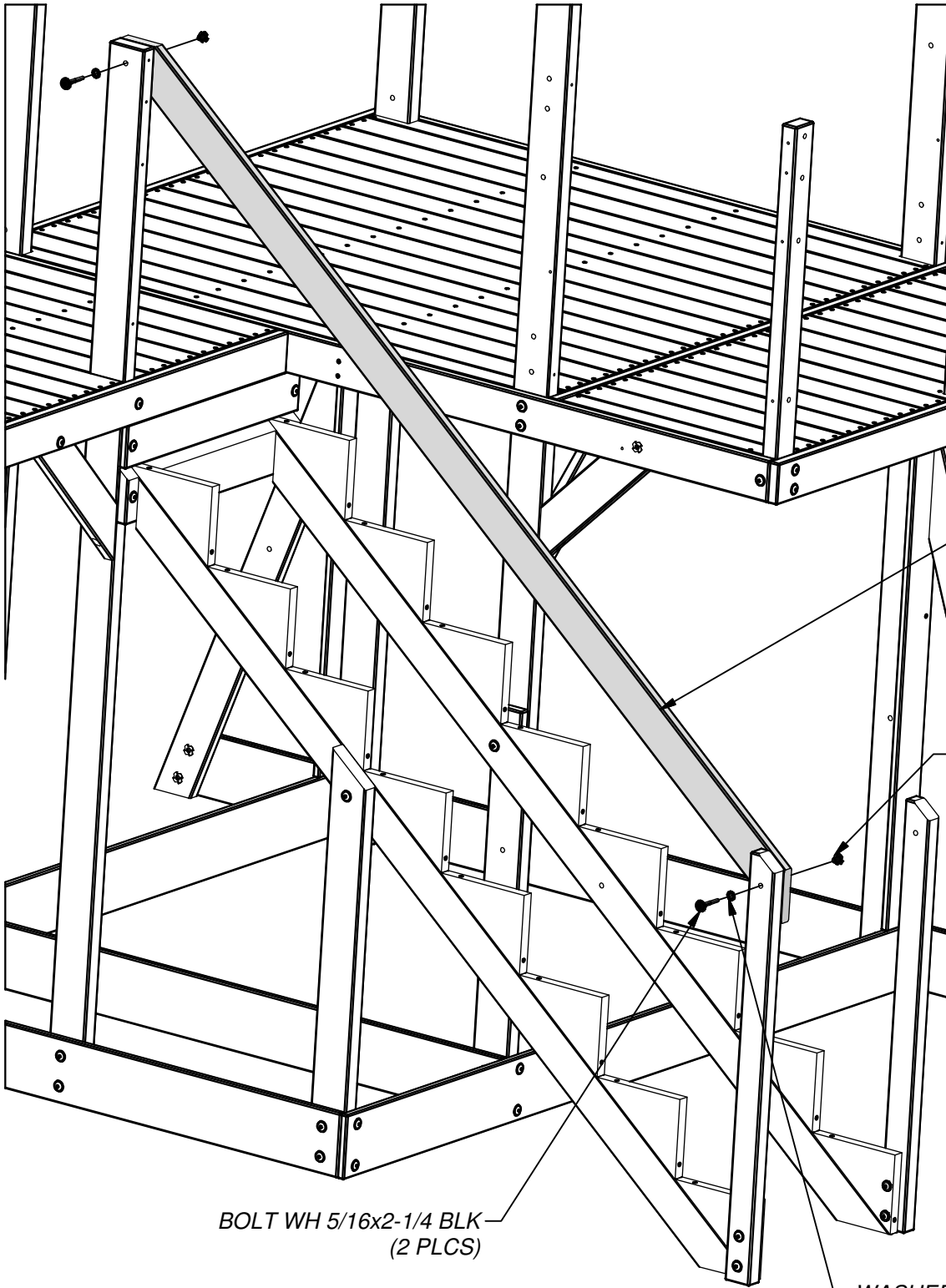

H1

T-NUT 5/16 BLK
(2 PLCS)

BOLT WH 5/16x2-1/4 BLK
(2 PLCS)

WASHER LOCK EXT 8x19 BLK
(2 PLCS)



H11 - HANDRAIL - W4L06133
 (1) 1"x3 3/8"x46" (24x86x1170)

STEP 31

(1) **BOLT WH 5/16x2-1/4 BLK**

(1) **LAG SCREW WH 5/16x2 BLK**

(2) **WASHER LOCK EXT 8x19 BLK**

(1) **T-NUT 5/16 BLK**

LAG SCREW WH 5/16x2 BLK
 (1 PLC)

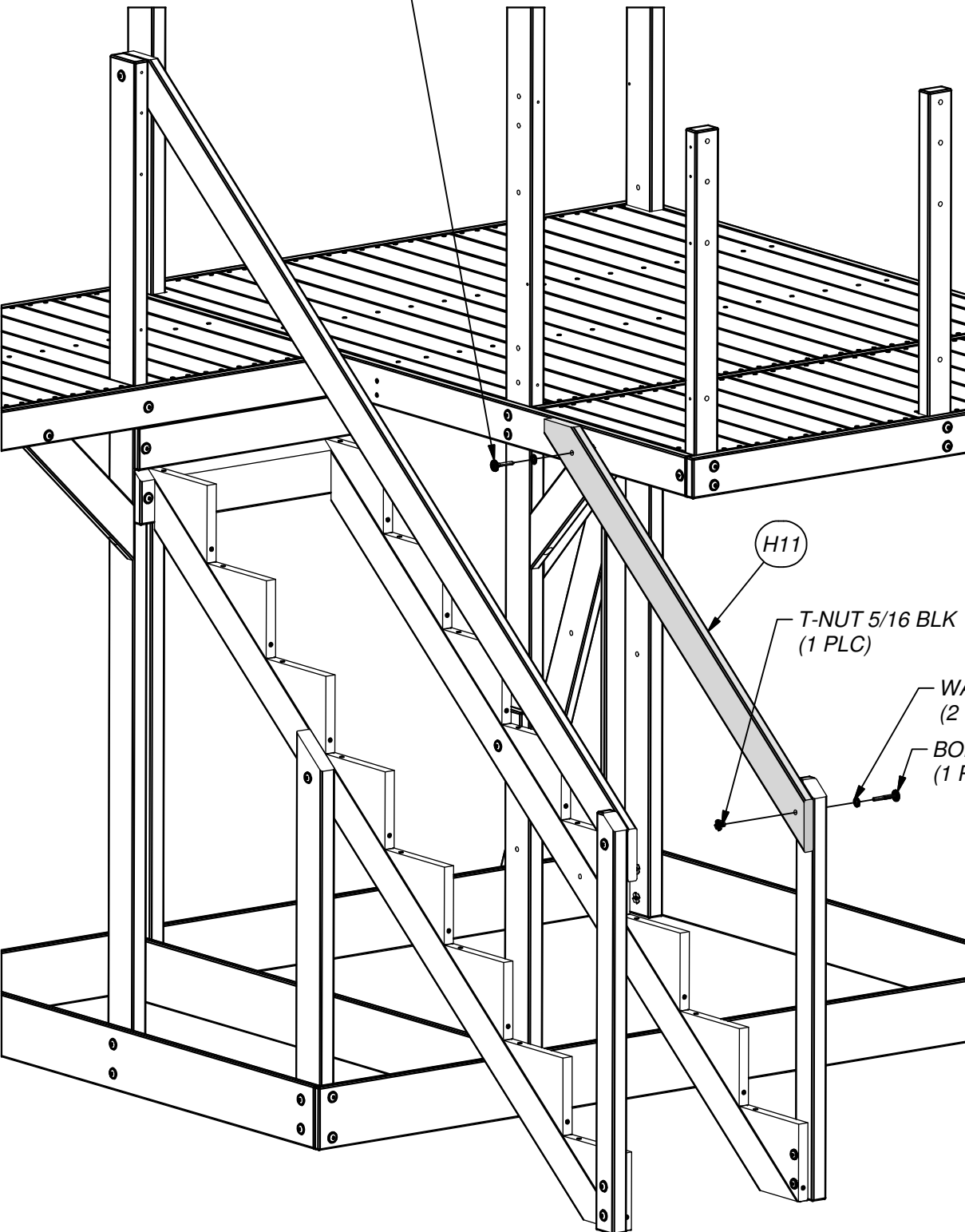

H11

T-NUT 5/16 BLK
 (1 PLC)

WASHER LOCK EXT 8x19 BLK
 (2 PLCS)

BOLT WH 5/16x2-1/4 BLK
 (1 PLC)

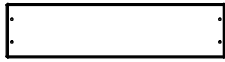

(1) **K10 - STAIR STEP BOARD - W4L06123**
 5/8"x4 5/8"x19" (16x119x483)



(3) **M23 - STAIR STEP BOARD - W4L06122**
 5/8"x3 1/4"x19" (16x83x483)

STEP 32

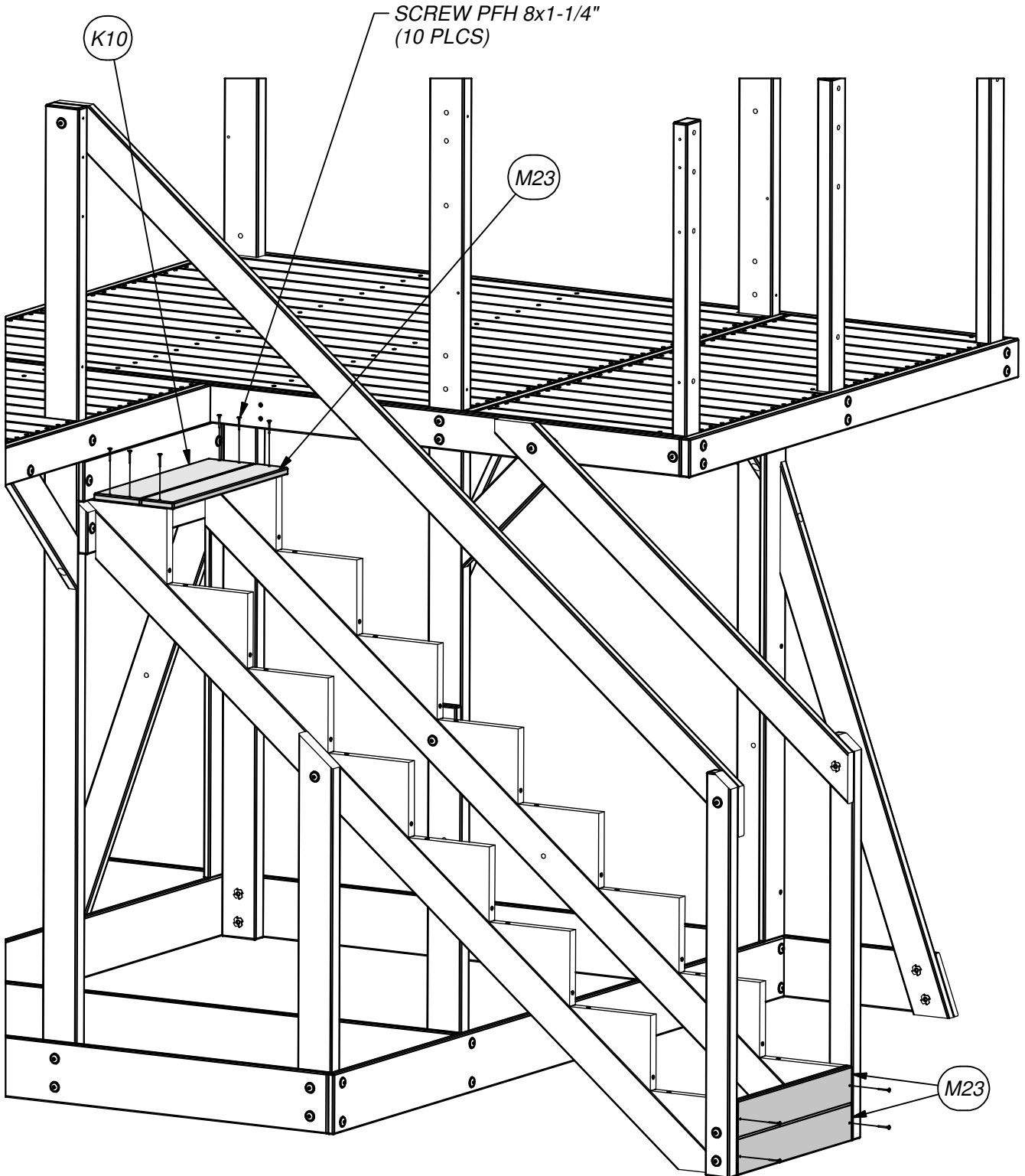
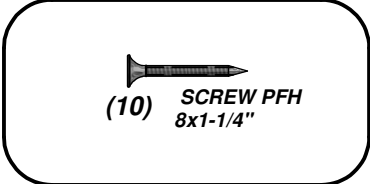



(2) **M23 - STAIR STEP BOARD - W4L06122**
5/8"x3 1/4"x19" (16x83x483)

STEP 33

 **(4) SCREW PFH**
8x1-1/4"

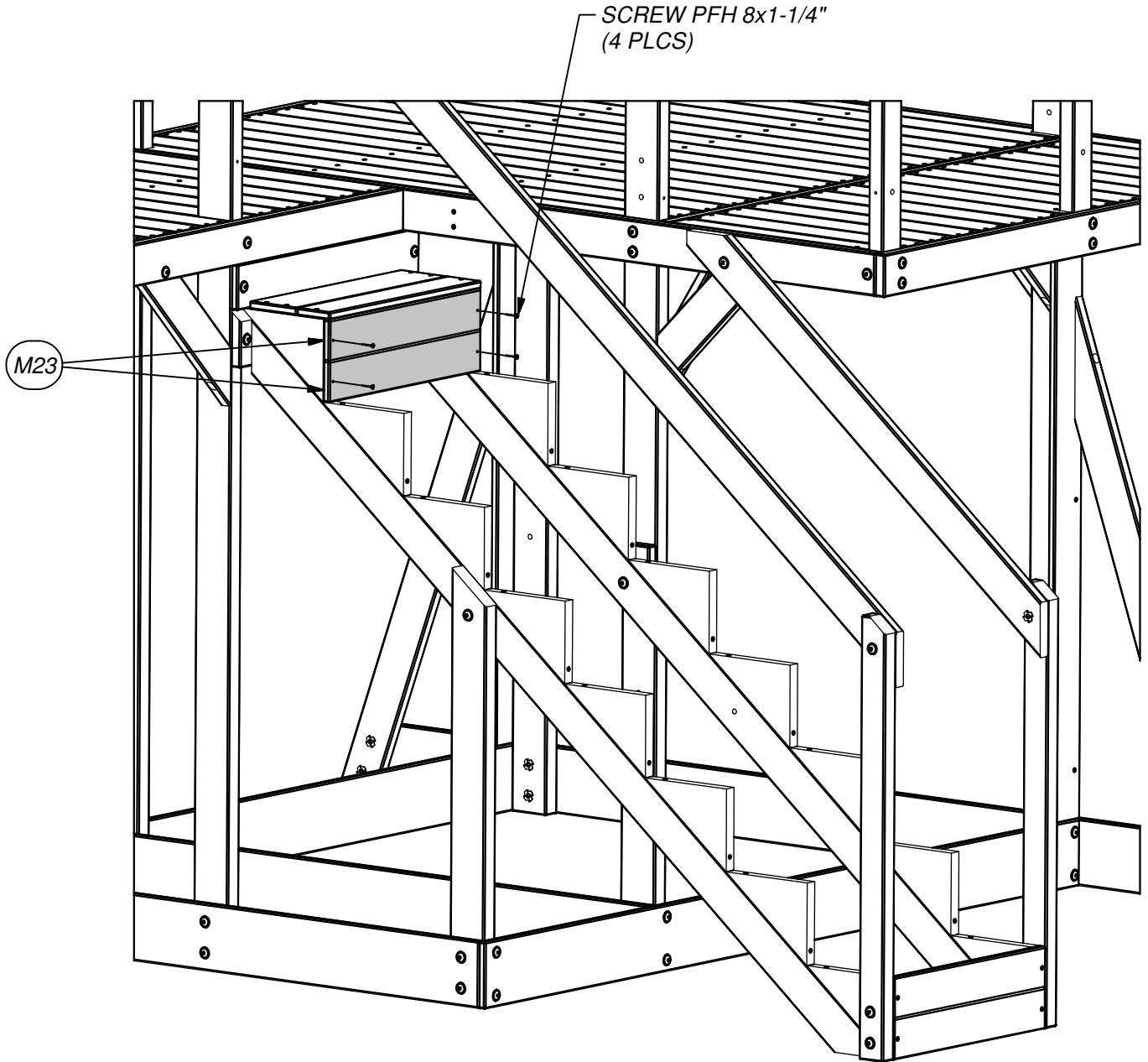

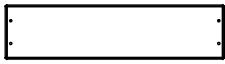

(7) **K10 - STAIR STEP BOARD - W4L06123**
5/8"x4 5/8"x19" (16x119x483)

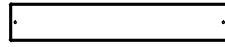

(19) **M23 - STAIR STEP BOARD - W4L06122**
5/8"x3 1/4"x19" (16x83x483)

STEP 34

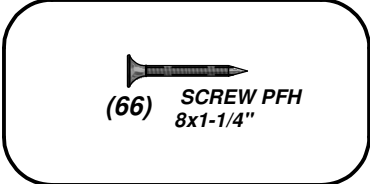

K10 7 PLCS

M23 19 PLCS

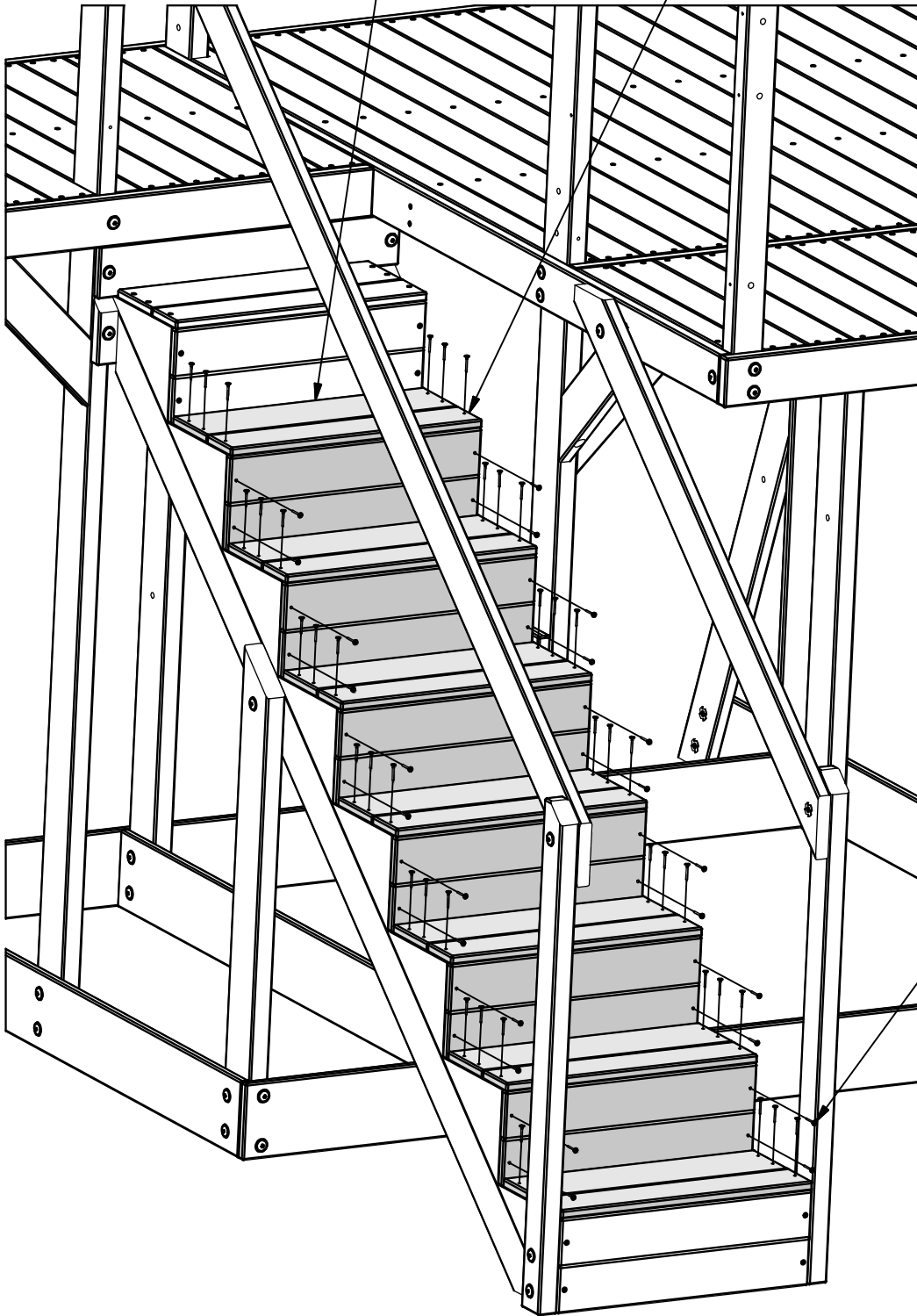

SCREW PFH 8x1-1/4"
(66 PLCS)

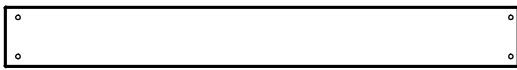

(1) **K14 - WALL RAIL - W4L06325**
5/8"x5 1/4"x44 5/8" (16x134x1135)

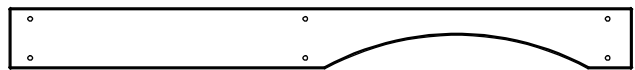

(1) **K6 - ARCHED RAIL - W4L06084**
5/8"x5 1/4"x54 1/8" (16x134x1374)

STEP 35

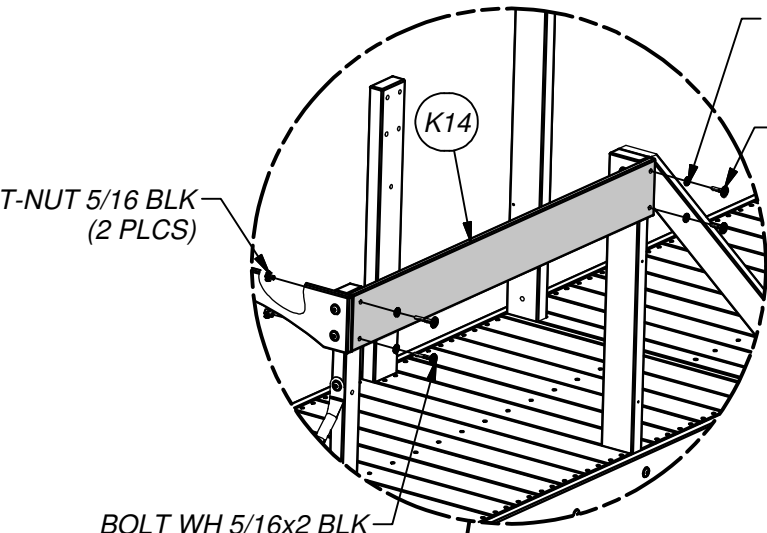

BOLT WH 5/16x2 BLK
(2 PLCS)

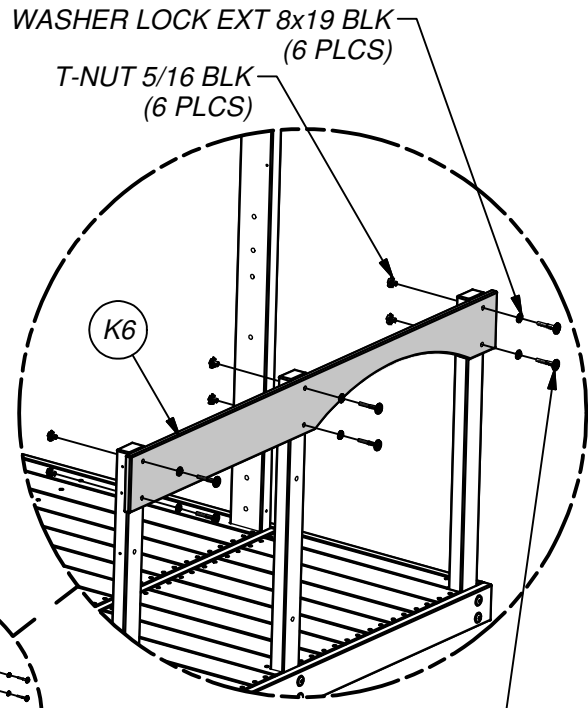
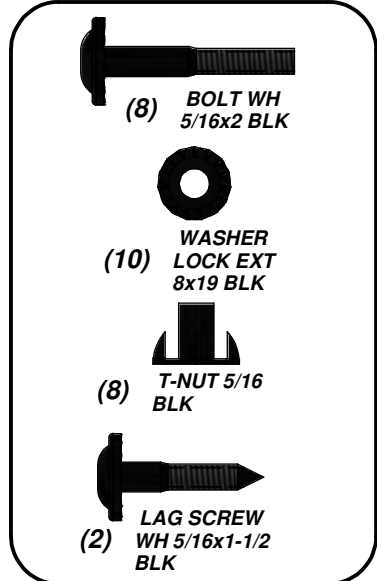

BOLT WH 5/16x2 BLK
(6 PLCS)

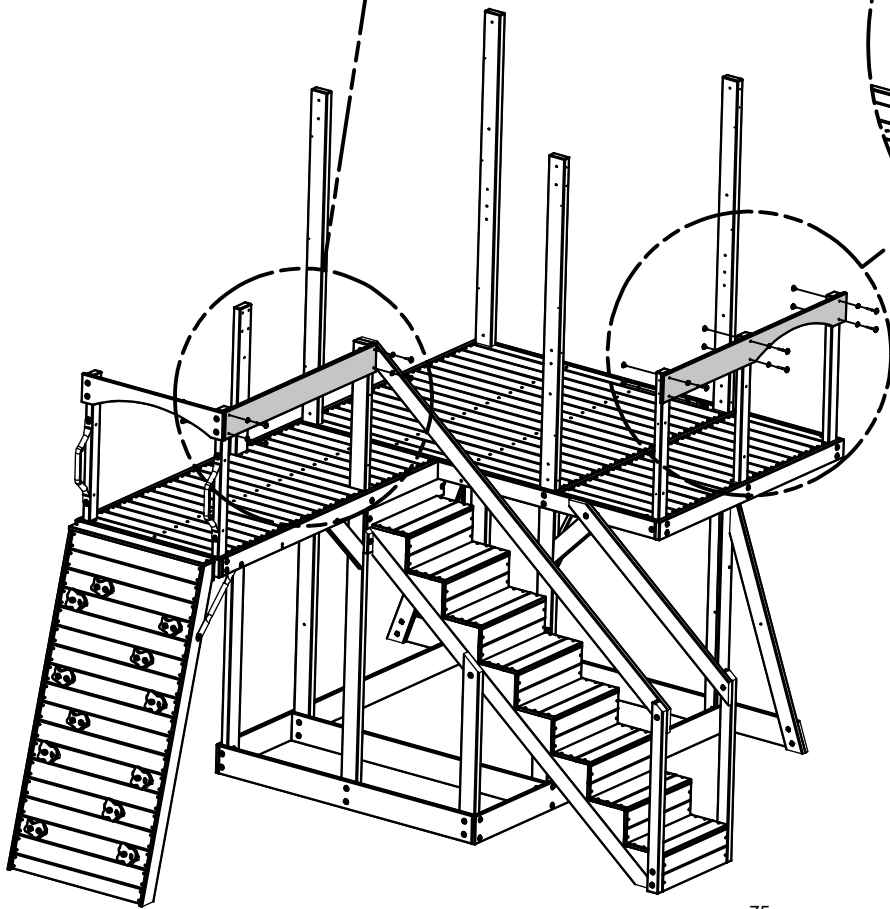

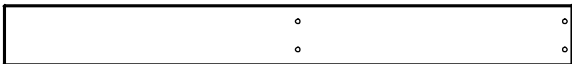

(1) **K8 - WALL RAIL - W4L06095**
5/8"x5 1/4"x49 1/2" (16x134x1256)

STEP 36

WASHER LOCK EXT 8x19 BLK
(4 PLCS)

BOLT WH 5/16x2 BLK
(2 PLCS)

K8

T-NUT 5/16 BLK
(2 PLCS)

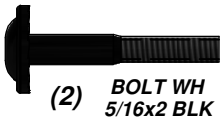

(2) **BOLT WH 5/16x2 BLK**



(4) **WASHER LOCK EXT 8x19 BLK**



(2) **T-NUT 5/16 BLK**



(2) **LAG SCREW WH 5/16x1-1/2 BLK**

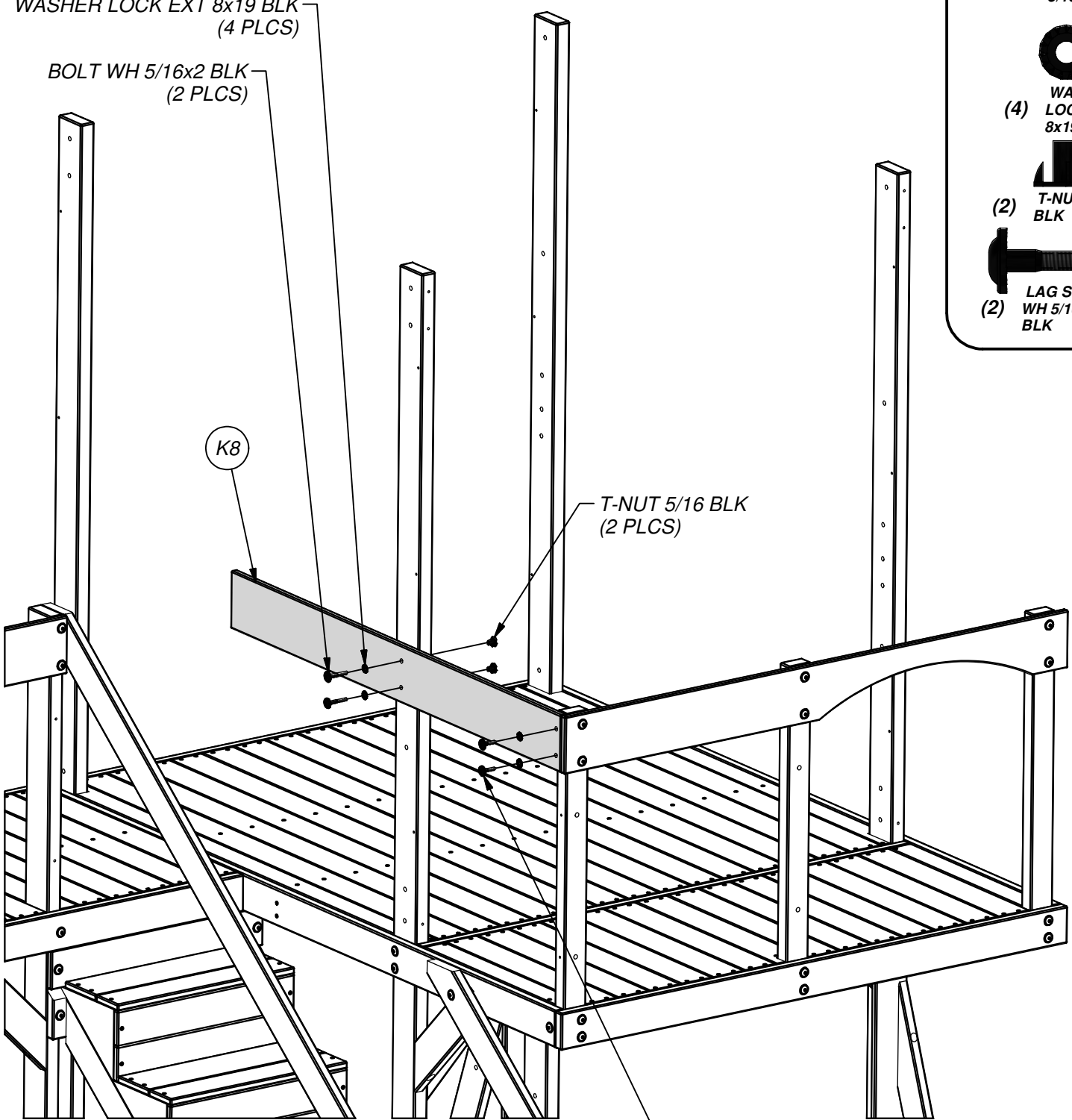

LAG SCREW WH 5/16x1-1/2 BLK
(2 PLCS)

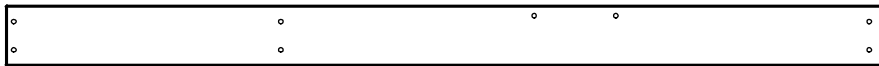

(1) **G1 - WALL RAIL - W4L06086**
1"x5 1/4"x76 3/4" (24x134x1948)

STEP 37

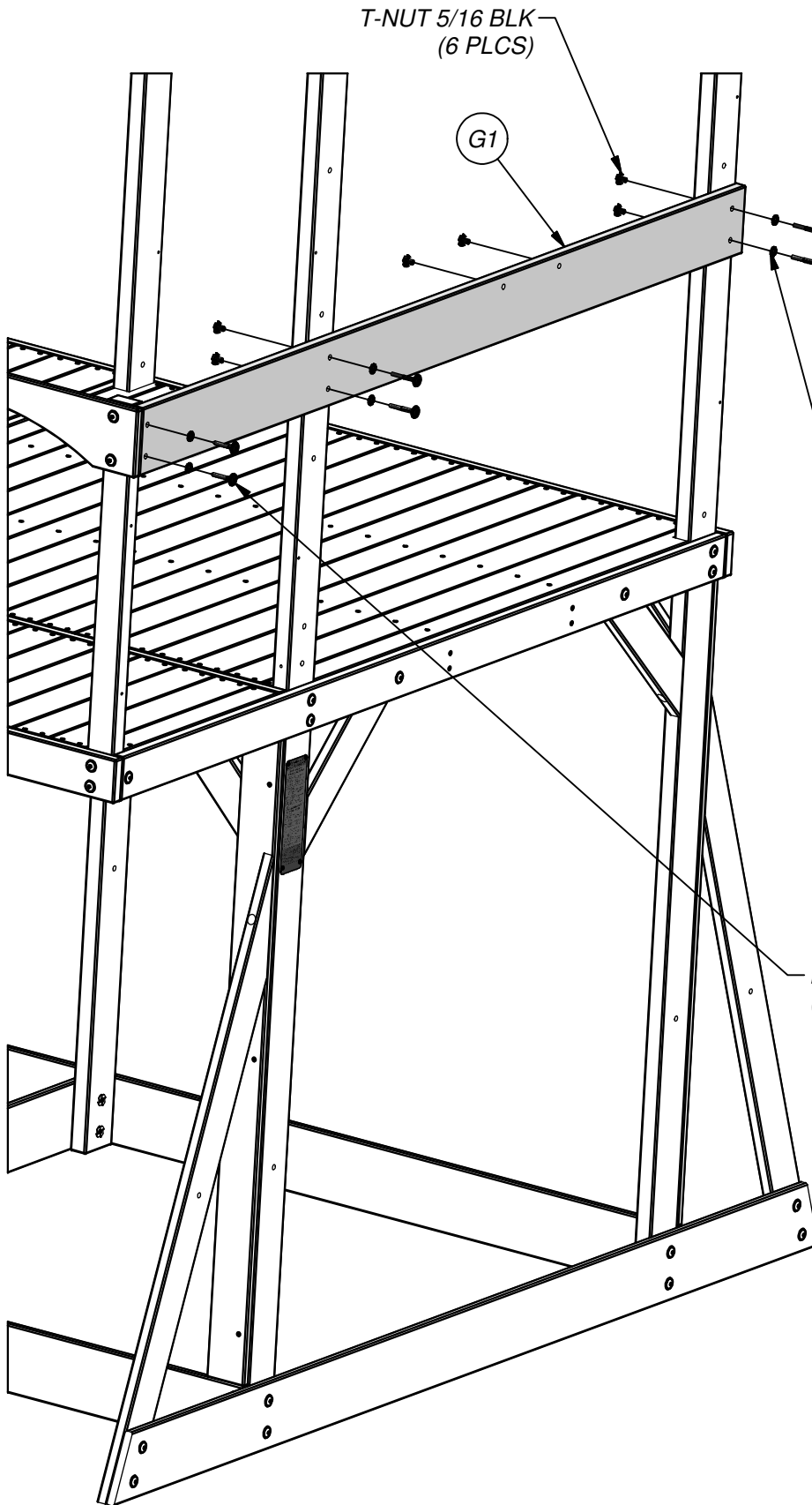

T-NUT 5/16 BLK
(6 PLCS)

G1

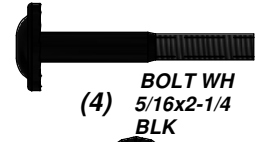

BOLT WH
(4) 5/16x2-1/4
BLK



(6) **WASHER
LOCK EXT**
8x19 BLK



(6) **T-NUT 5/16
BLK**



(2) **LAG SCREW**
WH 5/16x2
BLK

BOLT WH 5/16x2-1/4 BLK
(4 PLCS)

WASHER LOCK EXT 8x19 BLK
(6 PLCS)

LAG SCREW WH 5/16x2 BLK
(2 PLCS)

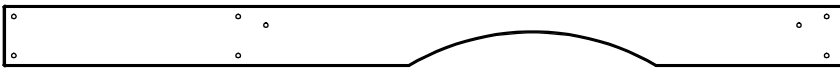

(1) **K3 - ARCHED RAIL - W4L06191**
5/8"x5 1/4"x73 1/8" (16x134x1858)

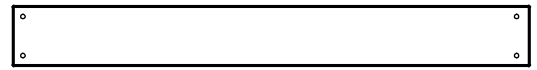

(1) **K13 - WALL RAIL - W4L06322**
5/8"x5 1/4"x45" (16x134x1142)

STEP 38

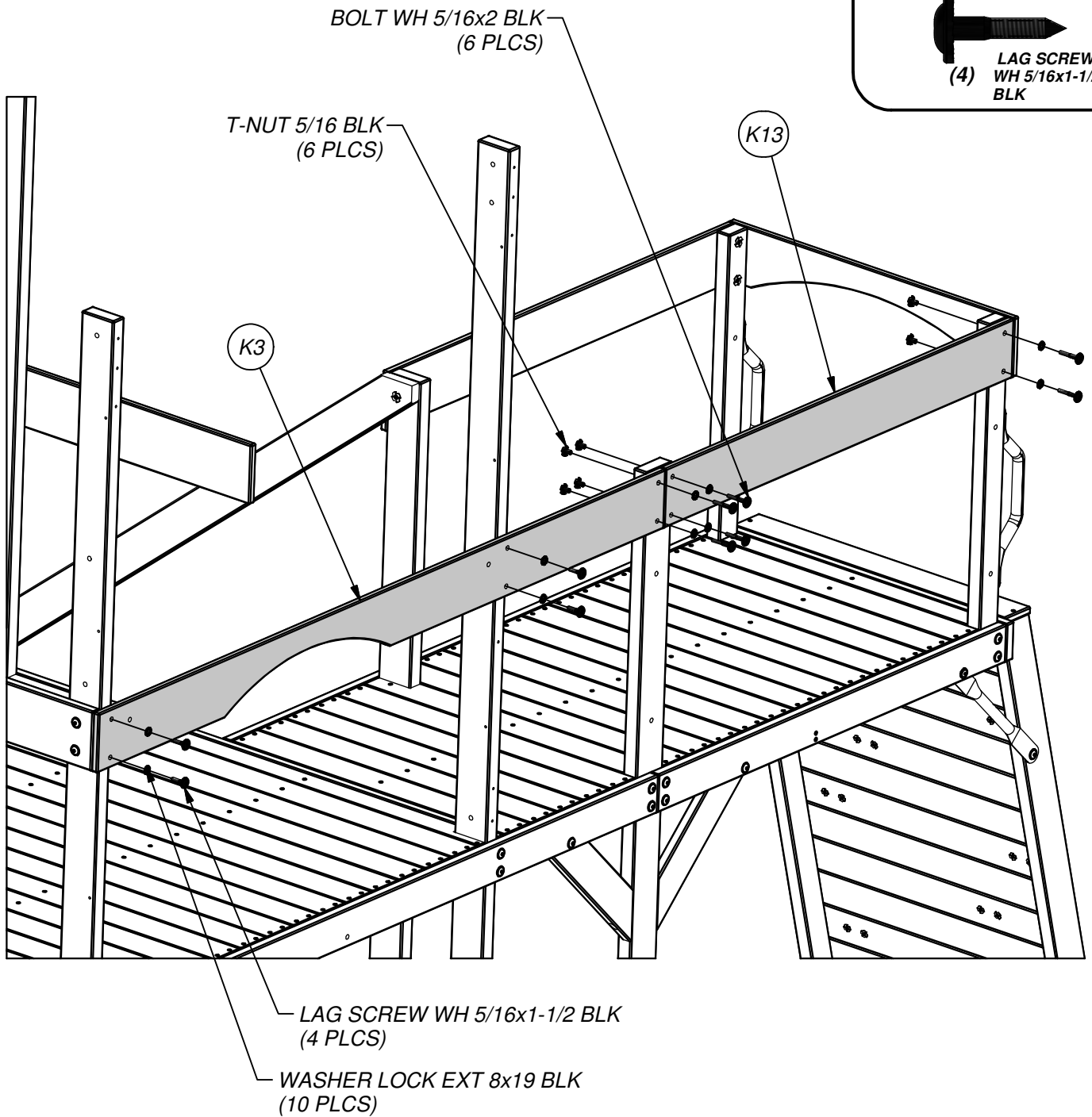
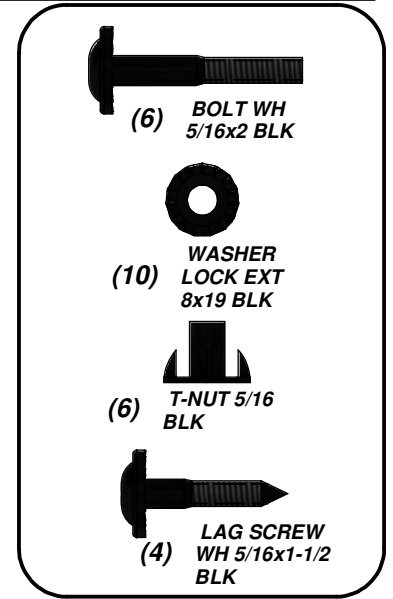

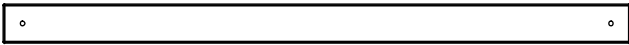

(1) H7 - WALL RAIL - W4L06100
1"x3 3/8"x54 1/2" (24x86x1384)



(1) M8 - ARCHED RAIL - W4L06101
5/8"x3 3/8"x54 1/2" (16x86x1384)

STEP 39

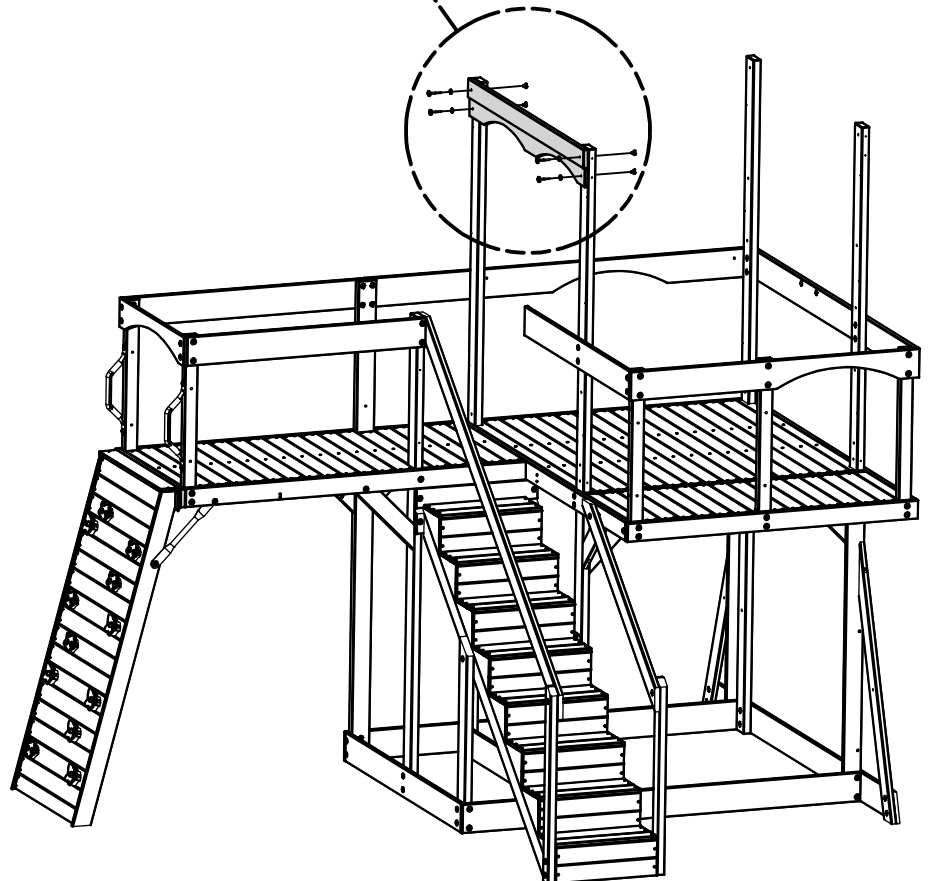
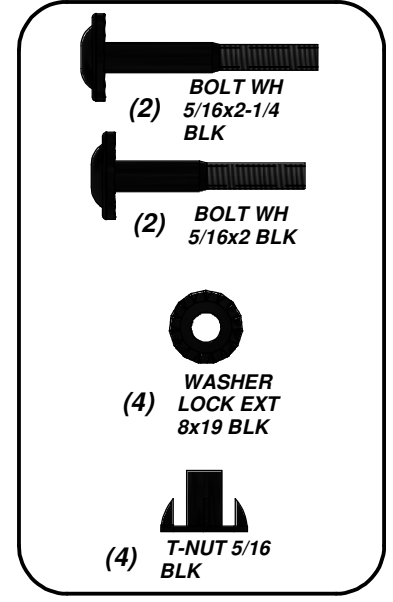
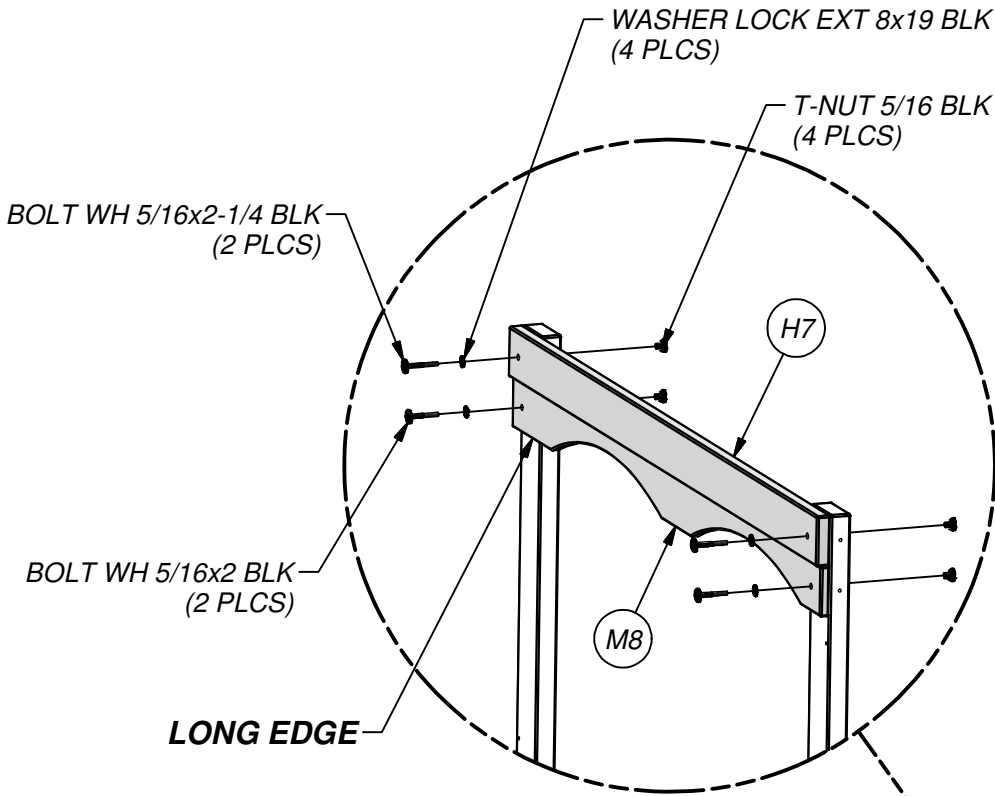

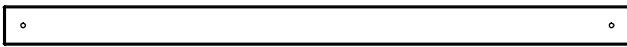

(1) **H7 - WALL RAIL - W4L06100**
1"x3 3/8"x54 1/2" (24x86x1384)

STEP 40

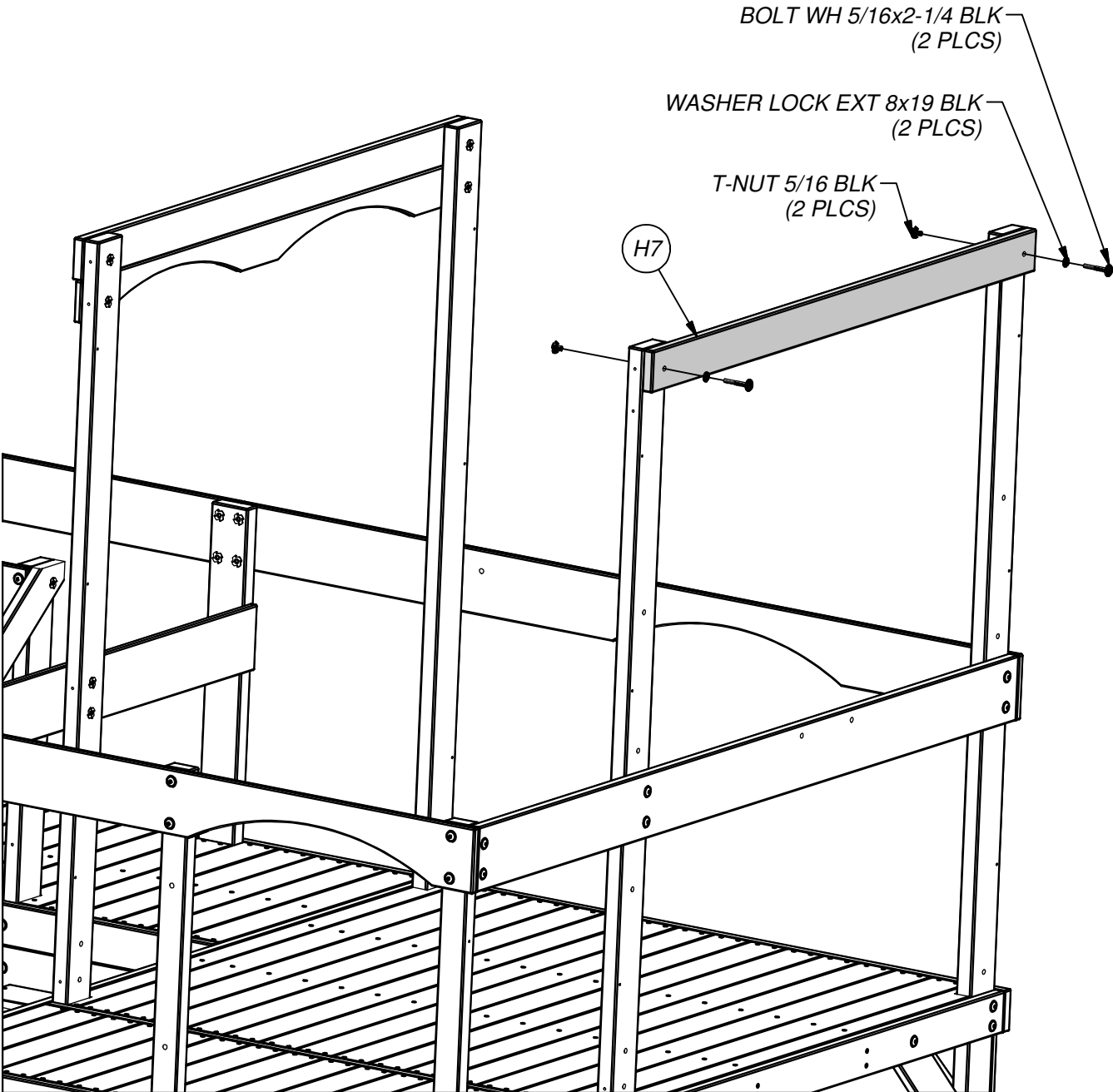
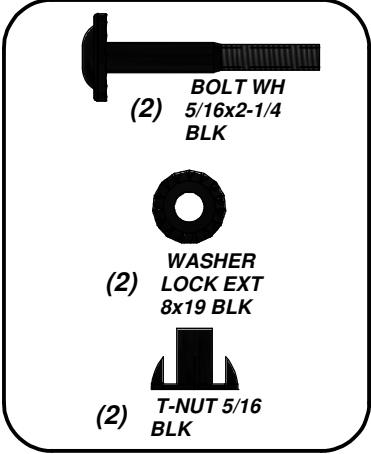

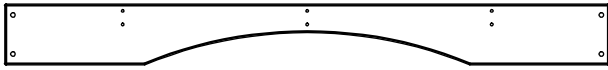

(1) **K7 - ARCHED RAIL - W4L06105**
5/8"x5 1/4"x52 1/2" (16x134x1334)

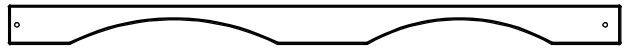

(1) **M10 - ARCHED RAIL - W4L06103**
5/8"x3 3/8"x53 1/8" (16x86x1350)

STEP 41

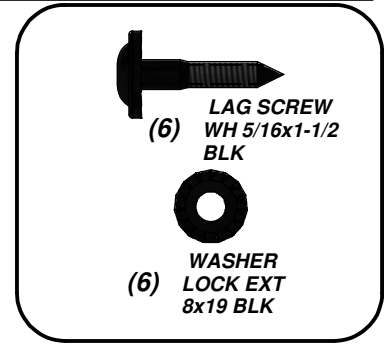

LAG SCREW
(6) WH 5/16x1-1/2
BLK

**WASHER
LOCK EXT**
(6) 8x19 BLK

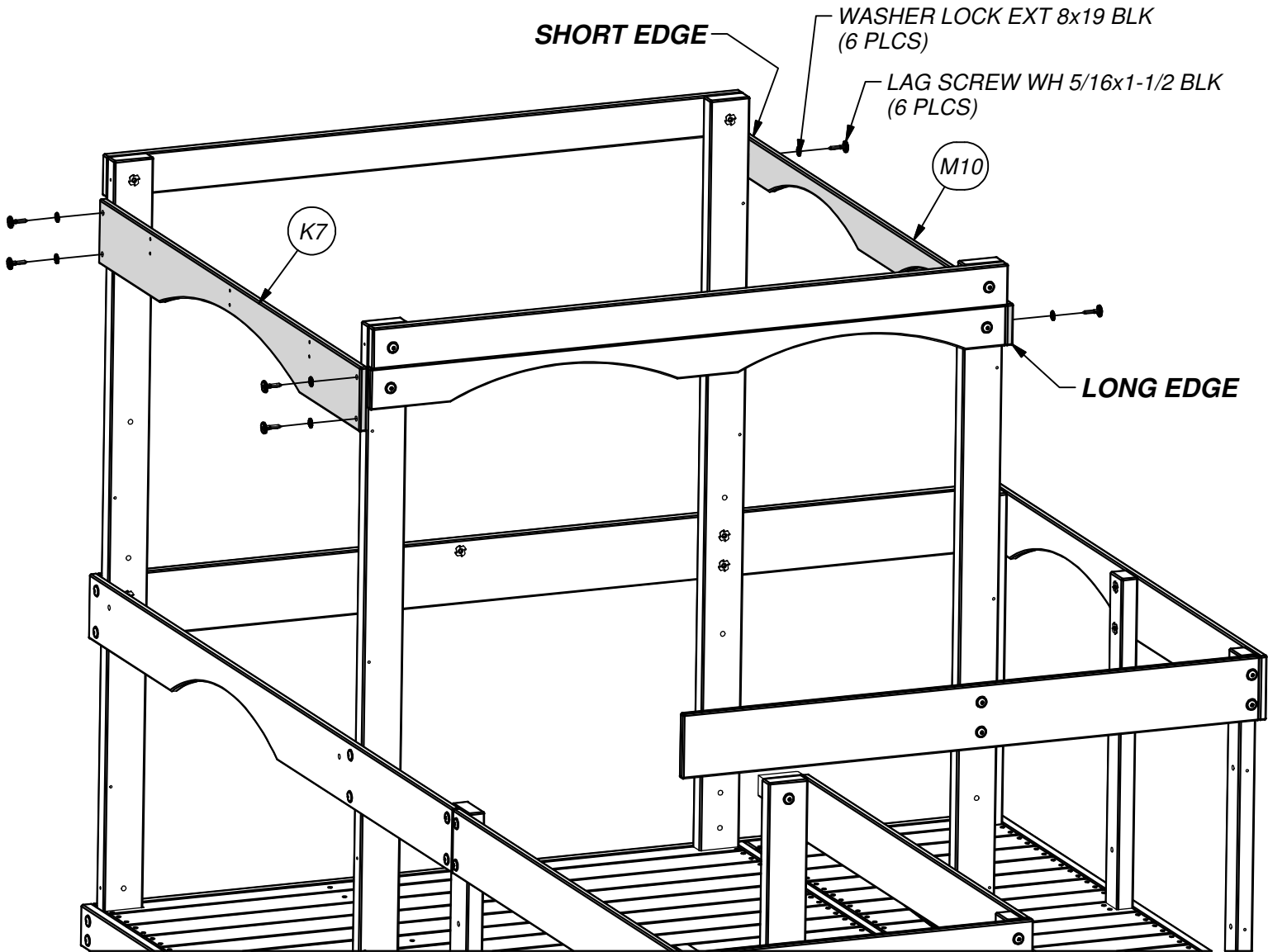

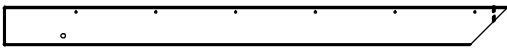

(4) **M11 - ROOF RAFTER - W4L06114**
5/8"x3 3/8"x43 7/8" (16x86x1114)

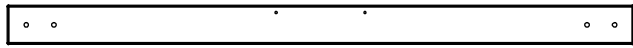

(2) **H9 - WALL RAIL - W4L06102**
1"x3 3/8"x54 3/8" (24x86x1382)

STEP 42

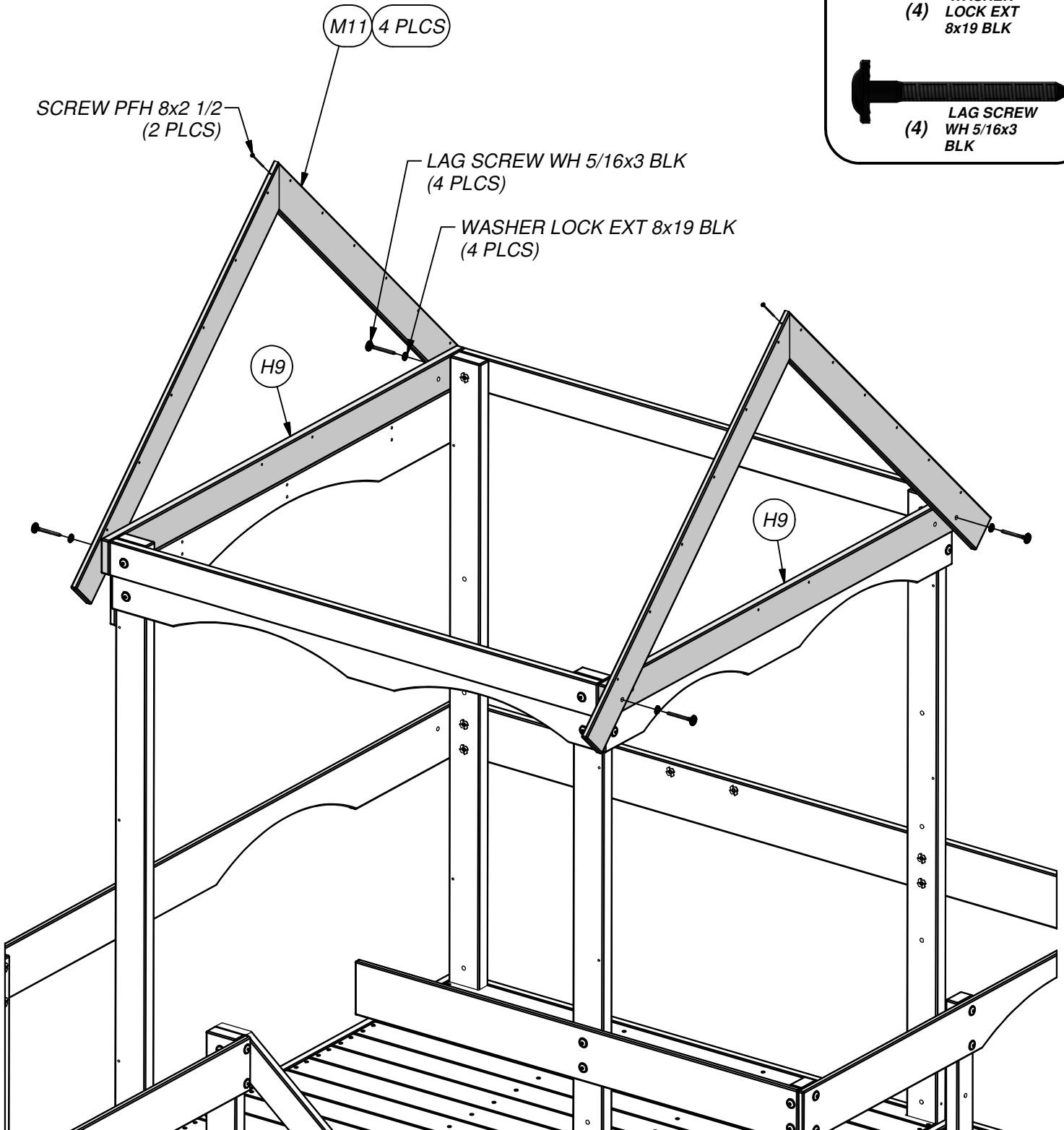
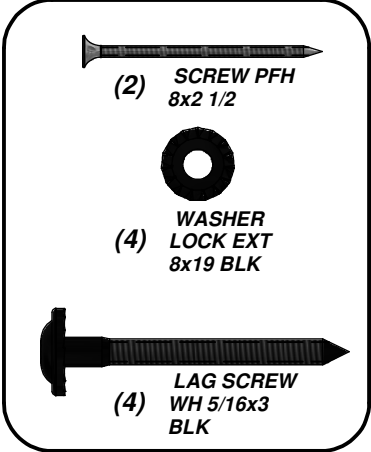

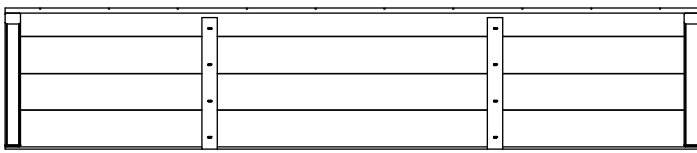

(1) **RP1 - ROOF PANEL - W2A01860**
1 3/8"x12 1/4"x59 1/2" (35x311x1532)

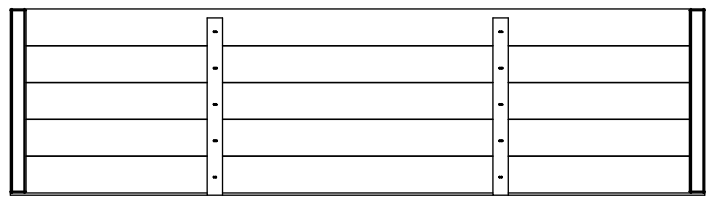

(1) **RP2 - ROOF PANEL - W2A01861**
1 3/8"x16 1/8"x59 1/2" (35x410x1532)



(1) **RP3 - ROOF PANEL - W2A01862**
1 3/8"x16 1/8"x59 1/2" (35x410x1532)

STEP 43

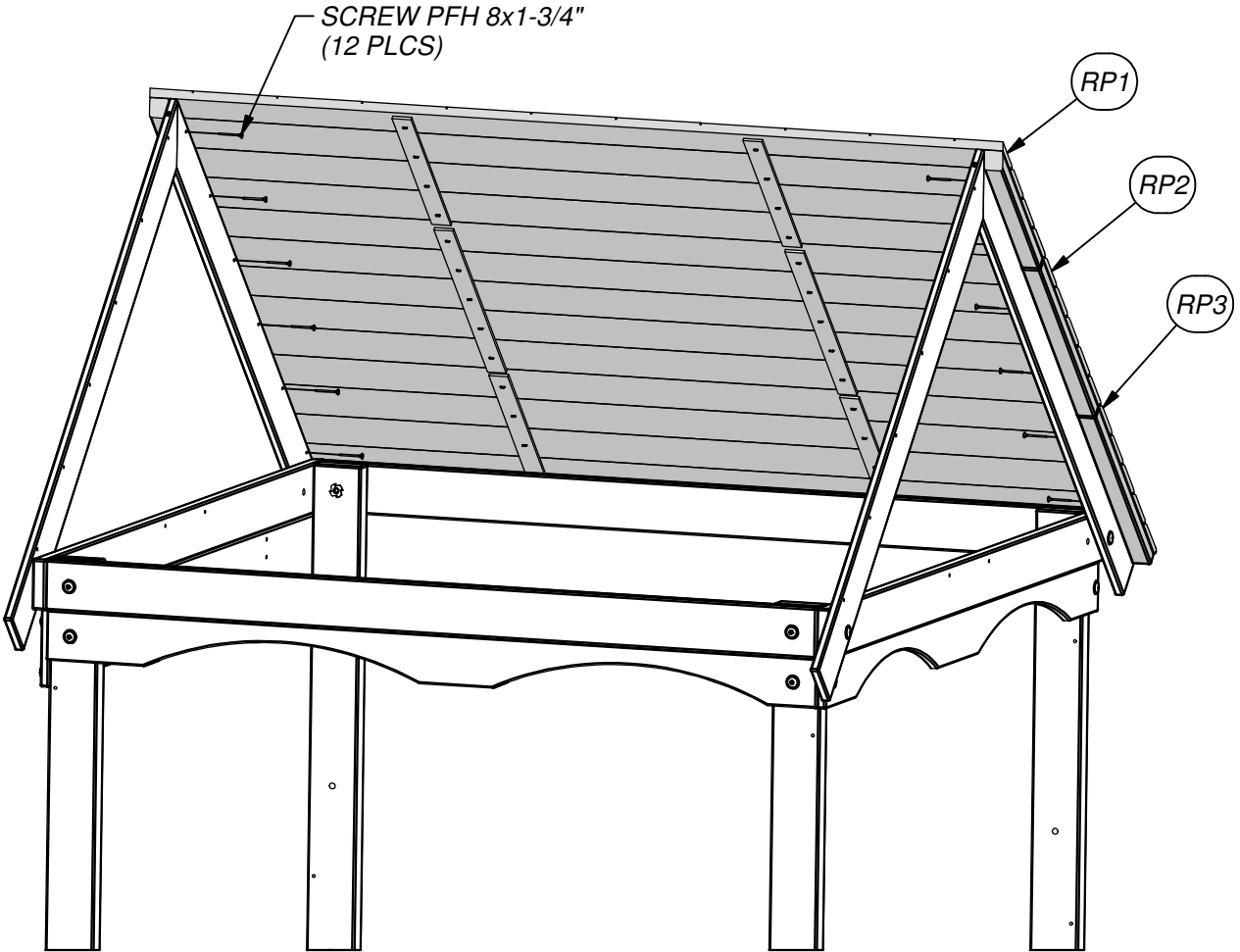
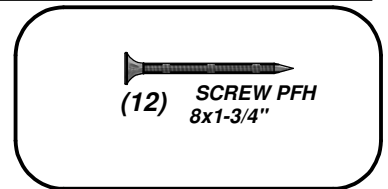

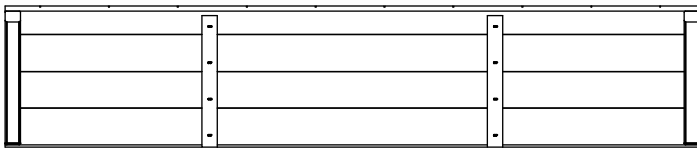

(1) **RP1 - ROOF PANEL - W2A01860**
1 3/8"x12 1/4"x59 1/2" (35x311x1532)

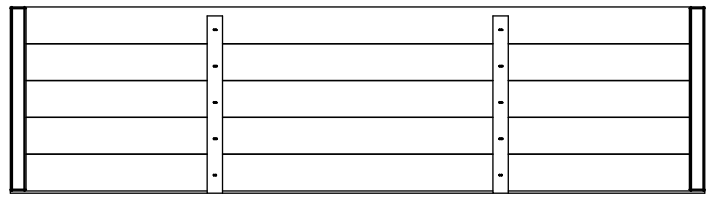

(1) **RP2 - ROOF PANEL - W2A01861**
1 3/8"x16 1/8"x59 1/2" (35x410x1532)



(1) **RP3 - ROOF PANEL - W2A01862**
1 3/8"x16 1/8"x59 1/2" (35x410x1532)



(2) - **90° L-BRACKET - BLK - A4M00555**

STEP 44

(12) **SCREW PFH 8x1-3/4"**

(4) **SCREW PWH 8x1/2 BLK**

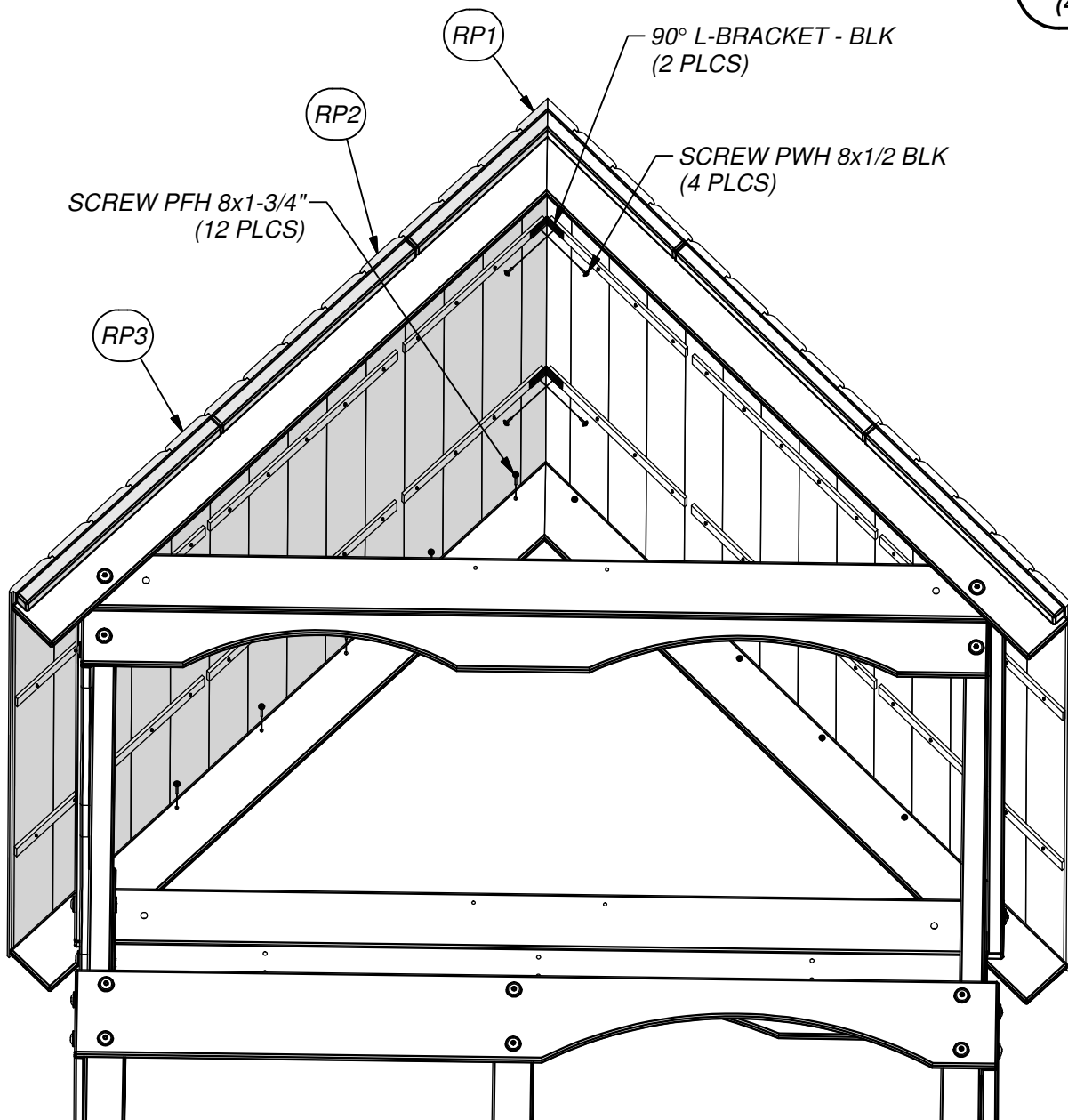



(2) **K11 - HALF MOON PLATE - W4L06115**
5/8"x5 1/4"x12 5/8" (16x134x320)



(4) **N6 - SUNBURST BOARD - W4L06117**
5/8"x2 3/8"x15 7/8" (16x60x404)

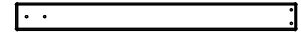

(2) **N2 - SUNBURST BOARD - W4L06116**
5/8"x2 3/8"x24 3/8" (16x60x620)

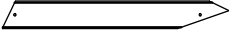

(8) **N4 - SUNBURST BOARD - W4L06118**
5/8"x2 3/8"x19 5/8" (16x60x500)

STEP 45

REPEAT ON OPPOSITE SIDE.

(32) **SCREW PFH**
8x1-1/8"

(4) **SCREW PFH**
8x1-1/2"

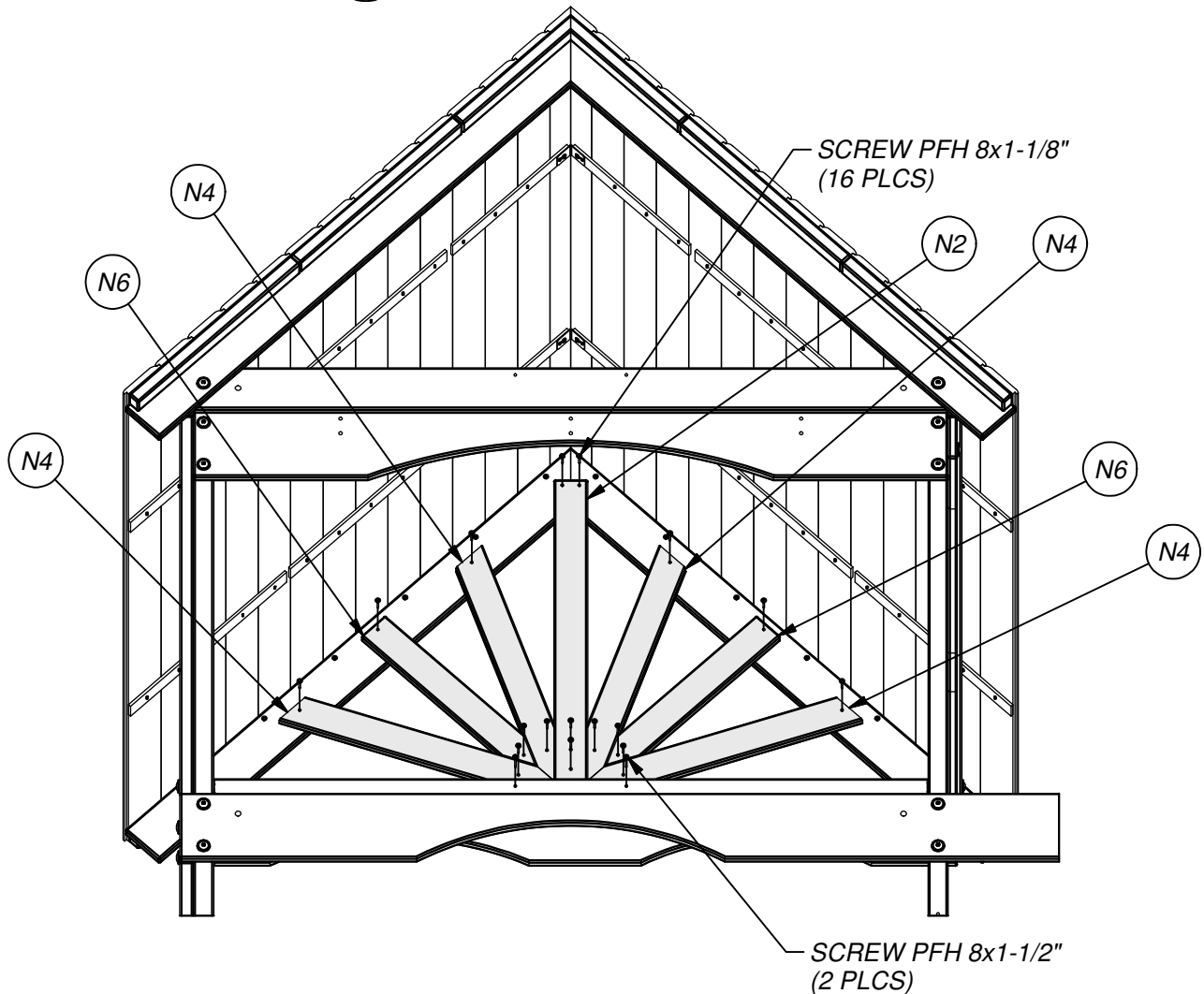
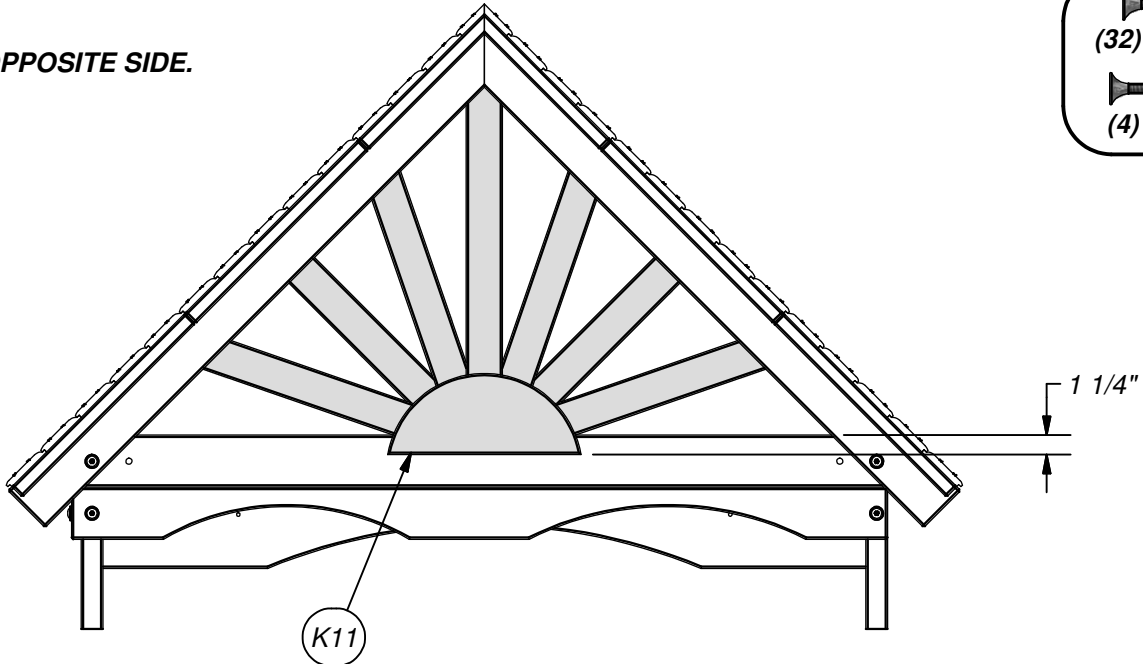

(1) M28 - WALL BOARD - W4L06180
5/8"x3 3/8"x61 1/4" (16x86x1557)

(1) M17 - WALL RAIL - W4L06094
5/8"x3 3/8"x27 1/4" (16x86x692)

(1) - 90° L-BRACKET - BLK - A4M00555

STEP 46

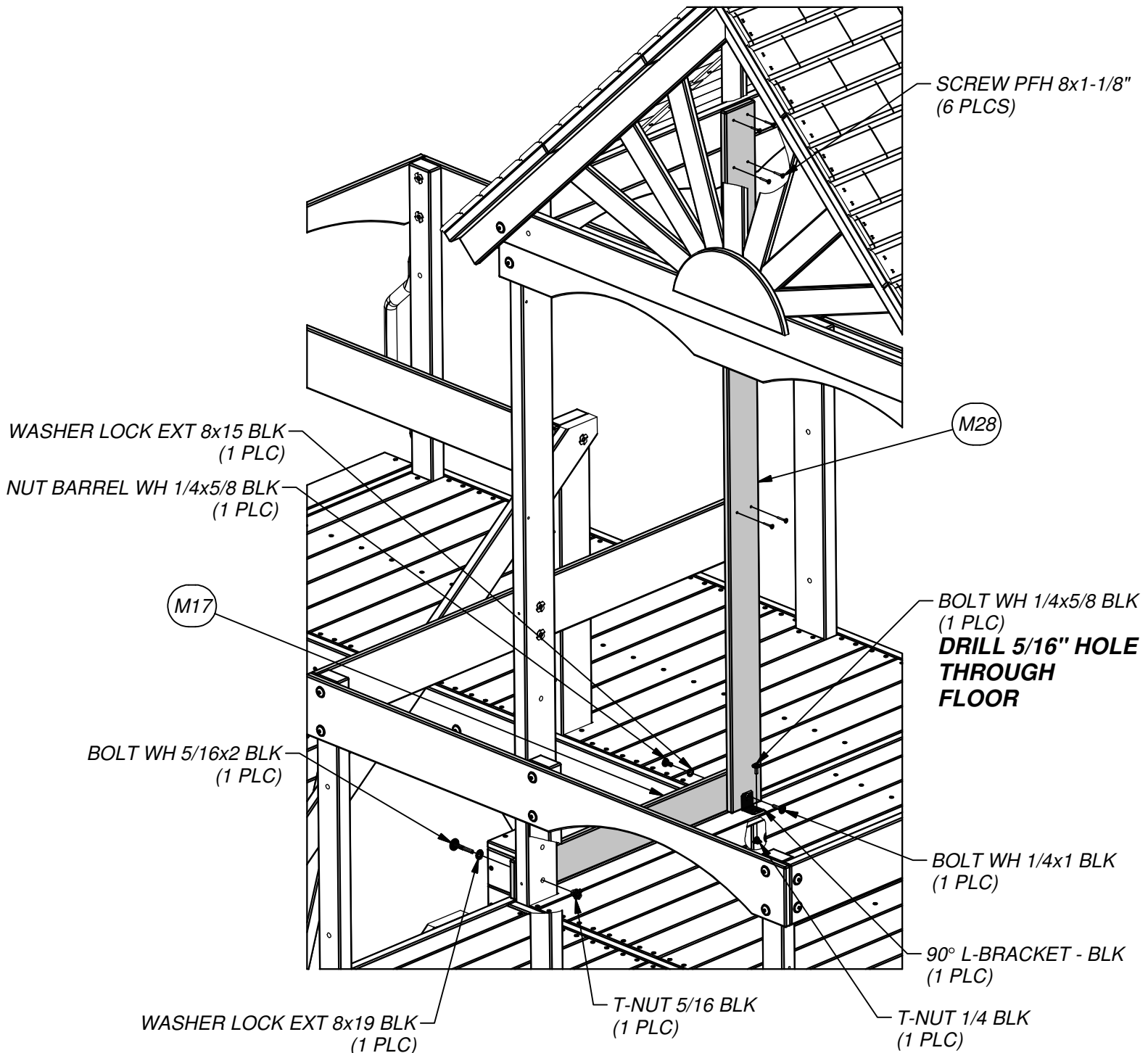
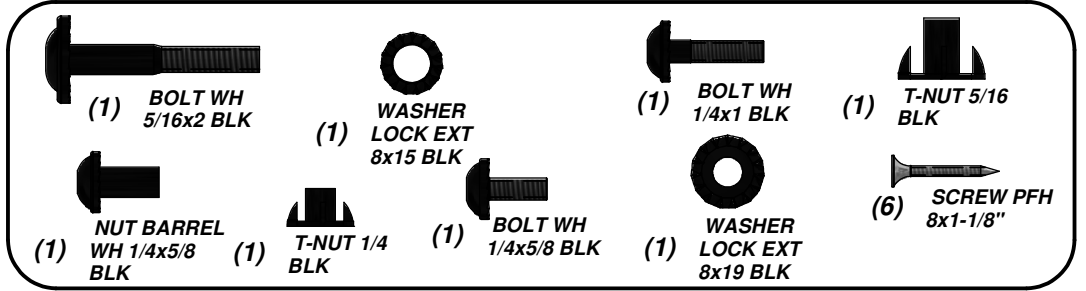

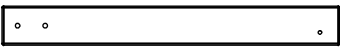

(1) **M13 - WALL RAIL - W4L06112**
5/8"x3 3/8"x29 1/4" (16x86x744)



(1) **M26 - WALL RAIL - W4L06110**
5/8"x3 3/8"x5 3/8" (16x86x138)

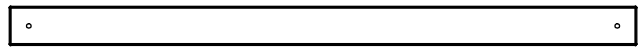

(1) **M7 - WALL RAIL - W4L06087**
5/8"x3 3/8"x54 1/2" (16x86x1384)

STEP 47

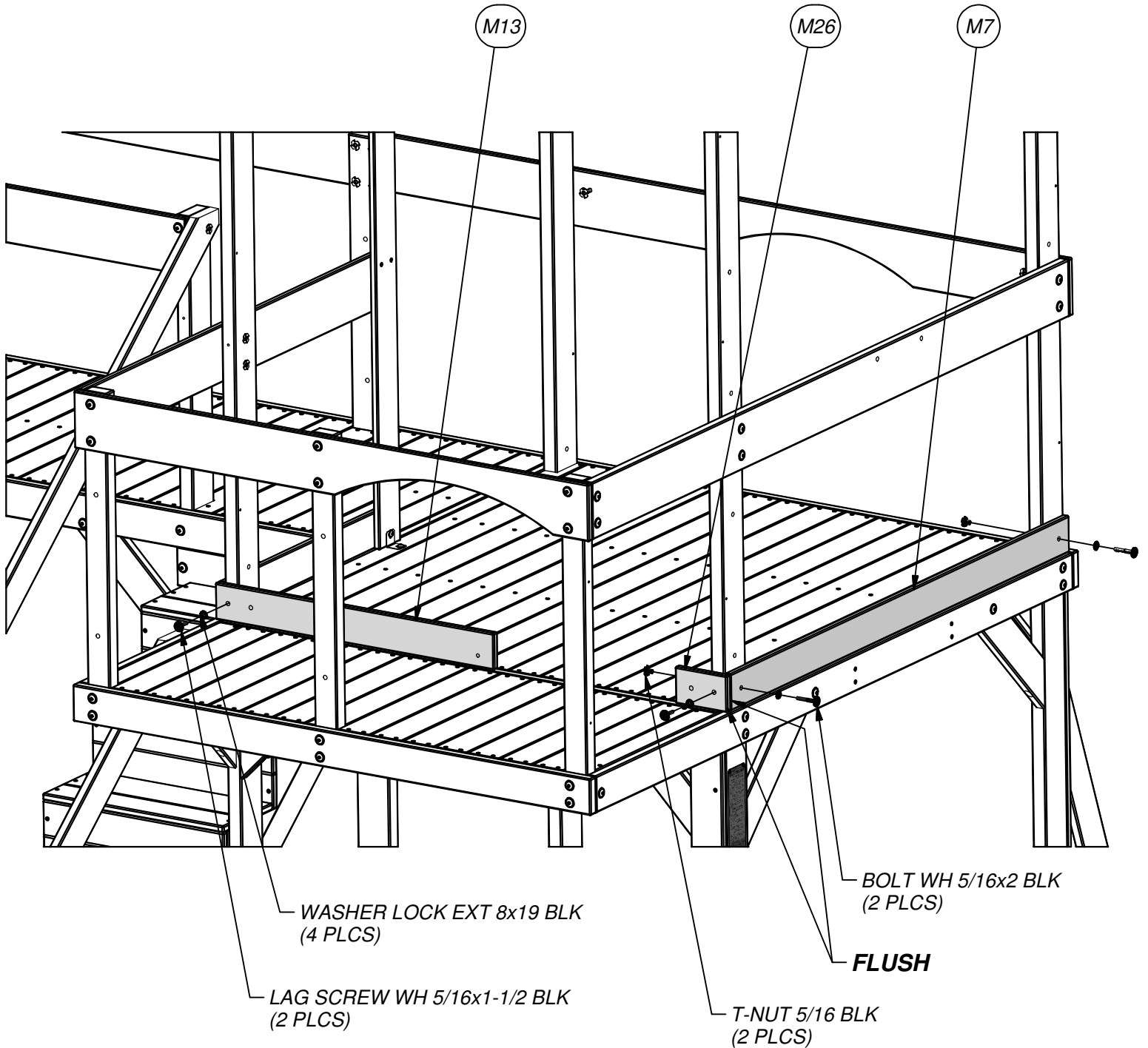
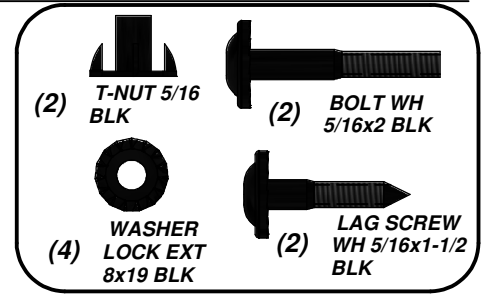

(1) - 90° L-BRACKET - BLK - A4M00555

(1) M14 - WALL RAIL - W4L06113
5/8"x3 3/8"x28 5/8" (16x86x728)

(1) M2 - WALL BOARD - W4L06097
5/8"x3 3/8"x61 1/4" (16x86x1557)

(1) H83 - WALL BOARD - W4L06182
1"x3 3/8"x61 1/4" (24x86x1557)

(1) M5 - WALL BOARD - W4L06111
5/8"x3 3/8"x61 1/4" (16x86x1557)

STEP 48

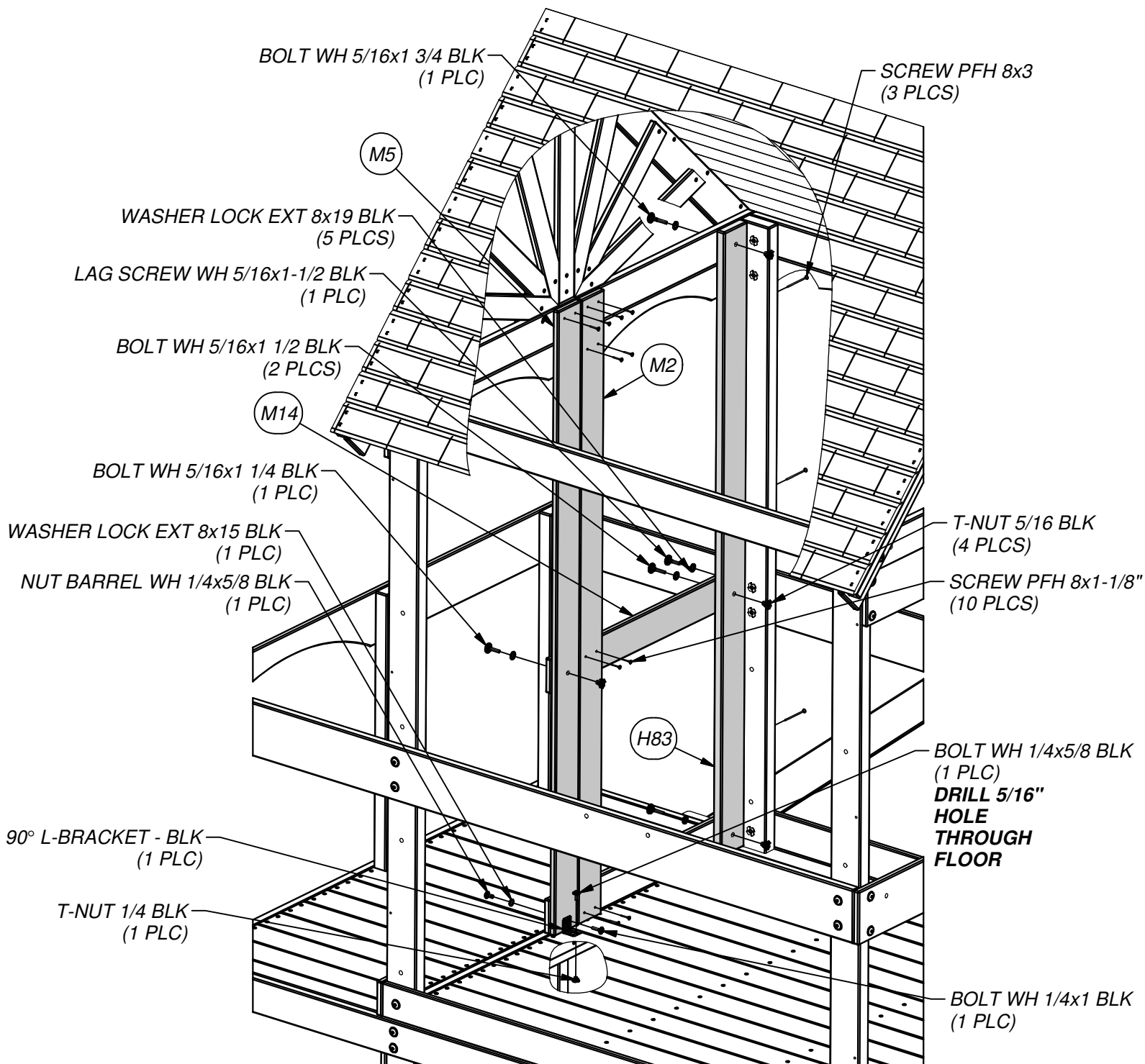
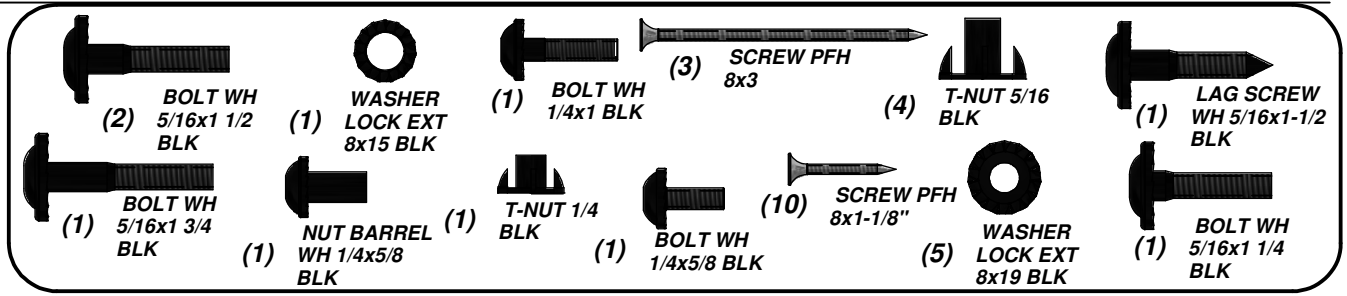

(2) **M24 - WALL RAIL - W4L06107**
 5/8"x3 3/8"x15 5/8" (16x86x398)

(1) **M25 - WALL RAIL - W4L06098**
 5/8"x3 3/8"x6 3/4" (16x86x172)

STEP 49

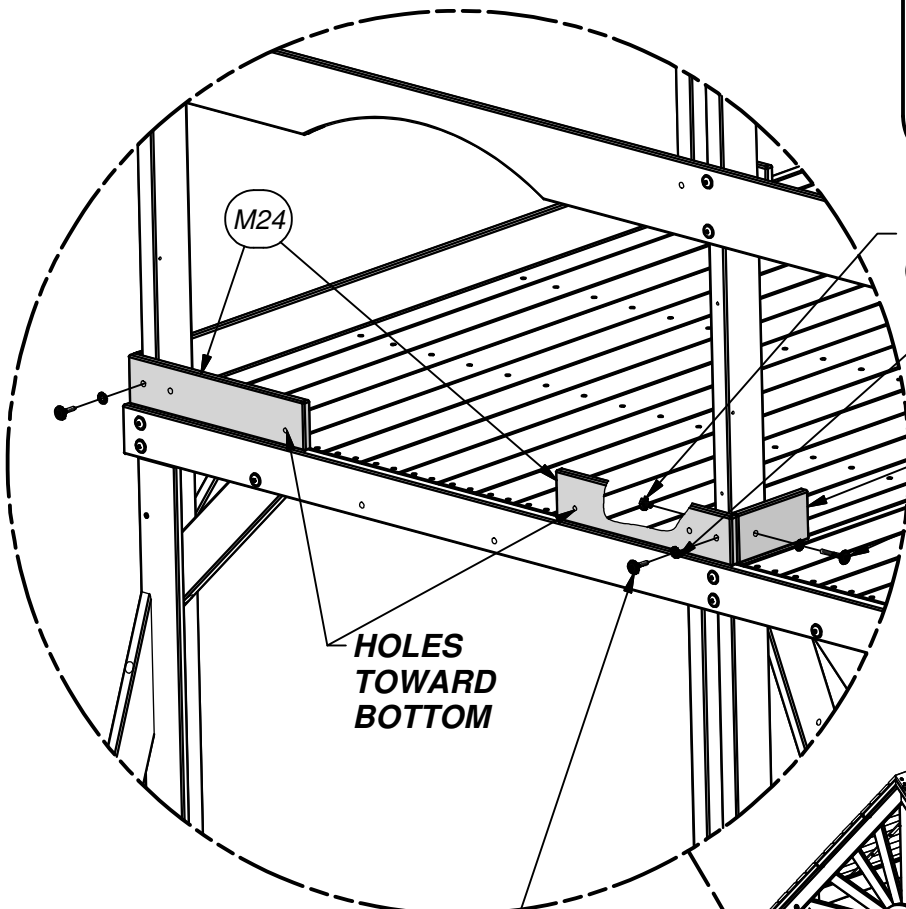
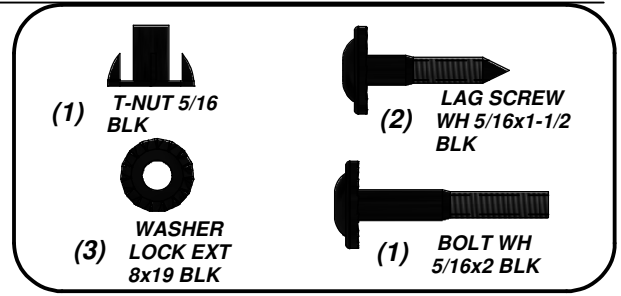

T-NUT 5/16 BLK (1 PLC)
 WASHER LOCK EXT 8x19 BLK (3 PLCS)
 M25
 BOLT WH 5/16x2 BLK (1 PLC)

HOLES TOWARD BOTTOM

LAG SCREW WH 5/16x1-1/2 BLK (2 PLCS)

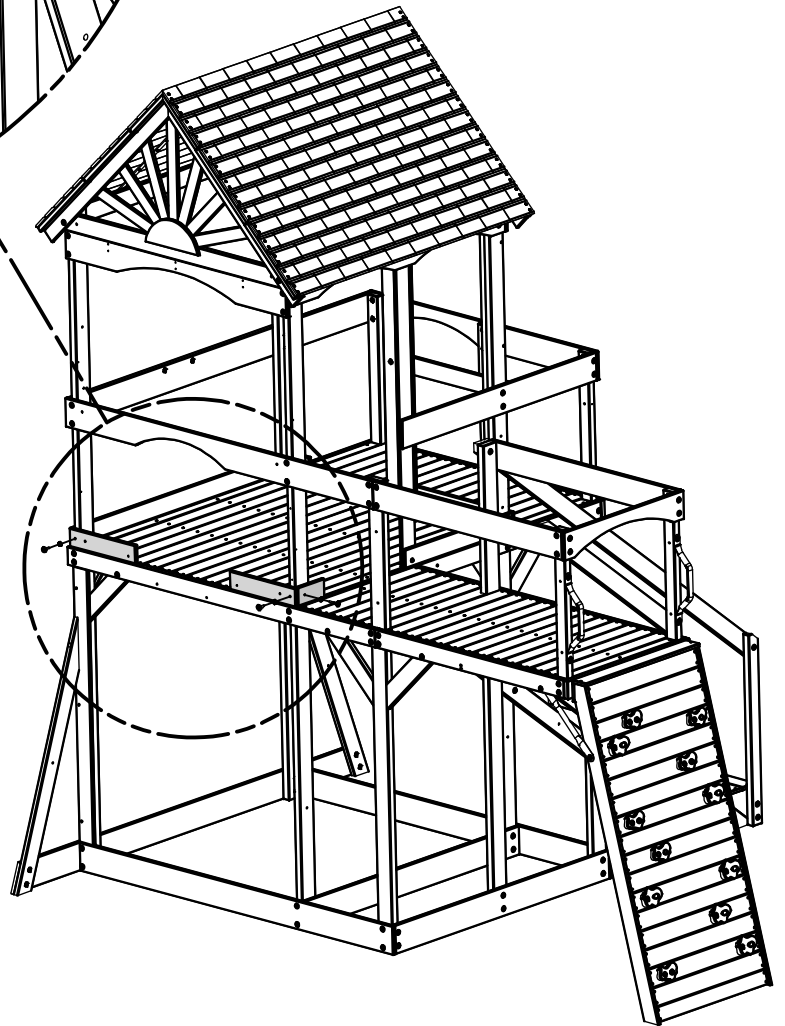

(1) H84 - WALL BOARD - W4L06183
1"x3 3/8"x61 1/4" (24x86x1557)

(1) M3 - WALL BOARD - W4L06099
5/8"x3 3/8"x61 1/4" (16x86x1557)

STEP 50

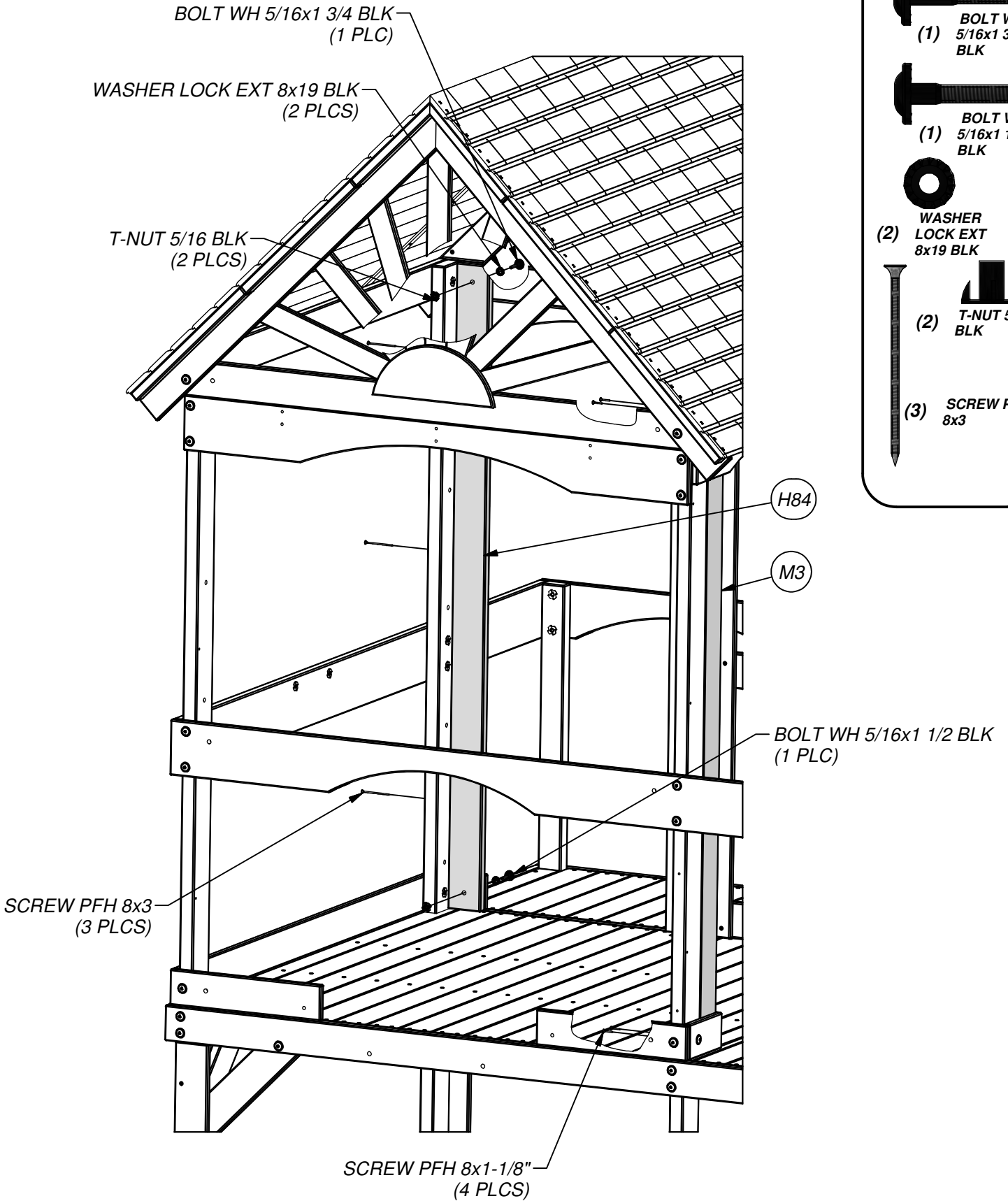

(4) SCREW PFH
8x1-1/8"

(1) BOLT WH
5/16x1 3/4
BLK

(1) BOLT WH
5/16x1 1/2
BLK

(2) WASHER
LOCK EXT
8x19 BLK

(2) T-NUT 5/16
BLK

(3) SCREW PFH
8x3



(2) - 90° L-BRACKET - BLK - A4M00555



(2) - HAND GRIP METAL BLACK 381 c/c - A4M00613

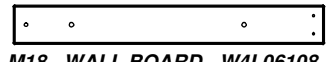

(2) M18 - WALL BOARD - W4L06108
5/8"x3 3/8"x27" (16x86x686)

STEP 51

(2) NUT BARREL WH 1/4x5/8 BLK	(2) WASHER LOCK EXT 8x15 BLK	(4) T-NUT 5/16 BLK	(4) SCREW PFH 8x1-1/8"
(4) BOLT WH 5/16x1/2 BLK	(2) T-NUT 1/4 BLK	(2) BOLT WH 1/4x5/8 BLK	(2) BOLT WH 1/4x1 BLK

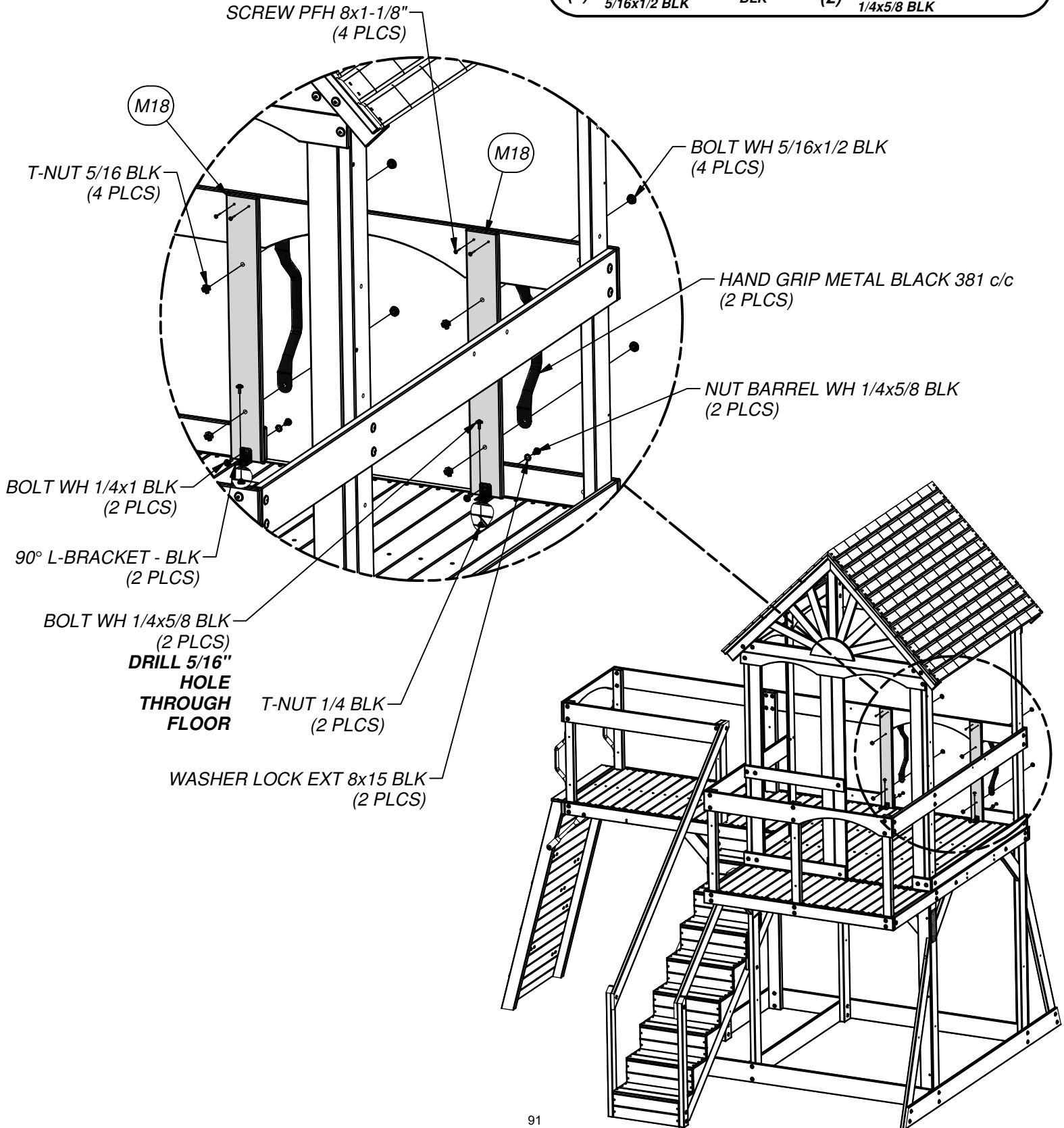

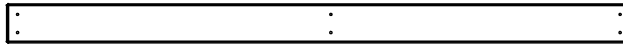

(2) **M9 - WALL BOARD - W4L06148**
5/8"x3 3/8"x54 1/4" (16x86x1377)

STEP 52

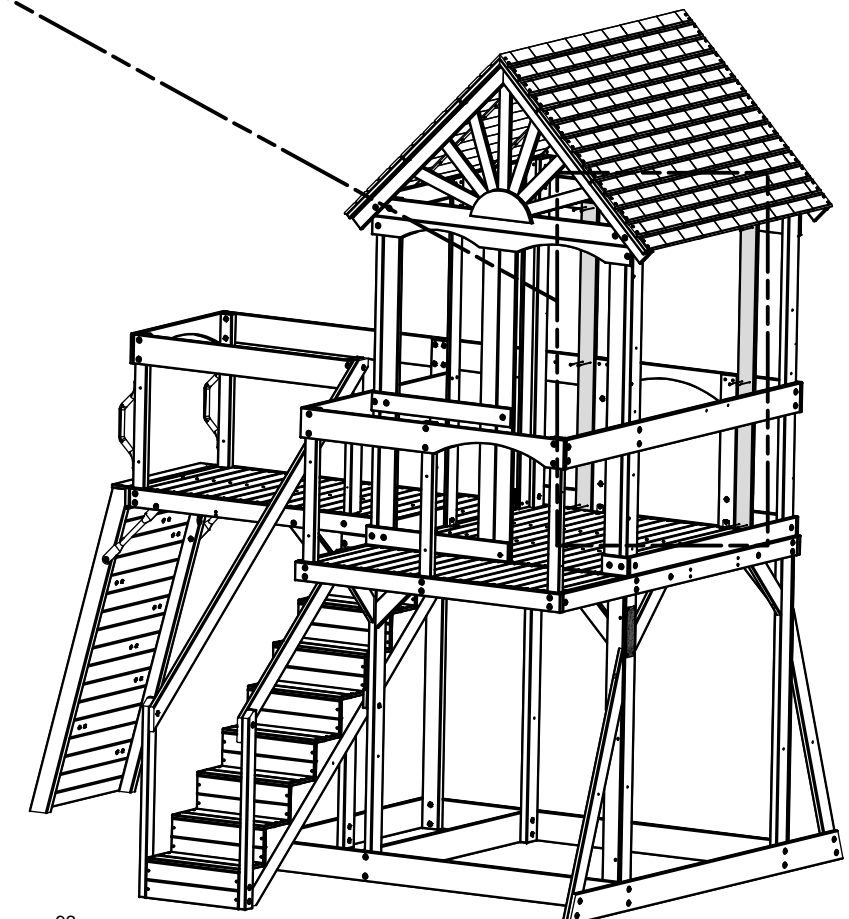
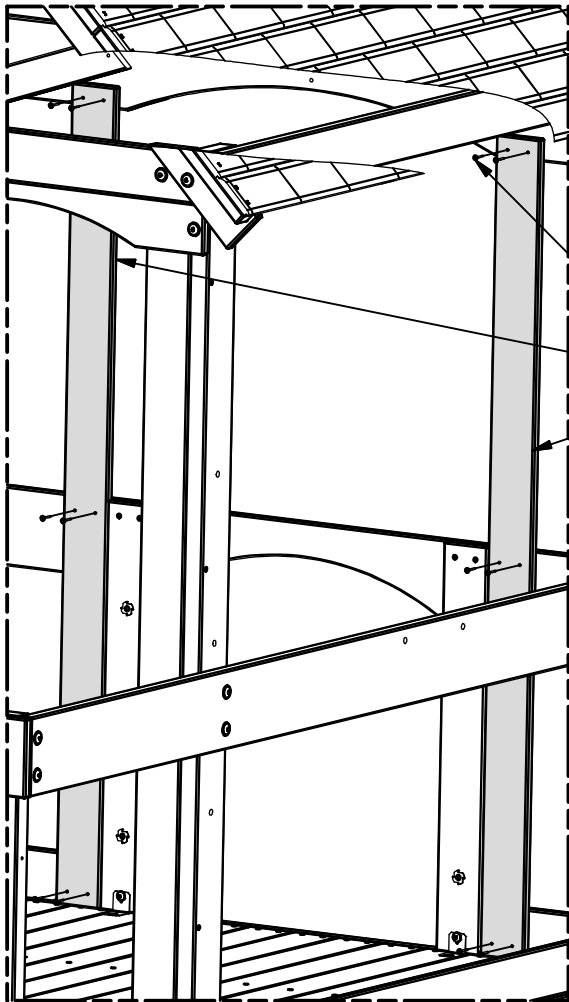
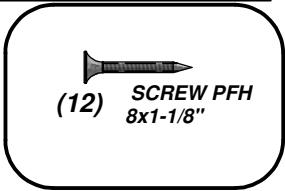

(2) H83 - WALL BOARD - W4L06182
1"x3 3/8"x61 1/4" (24x86x1557)

(2) M4 - WALL BOARD - W4L06109
5/8"x3 3/8"x61 1/4" (16x86x1557)

STEP 53

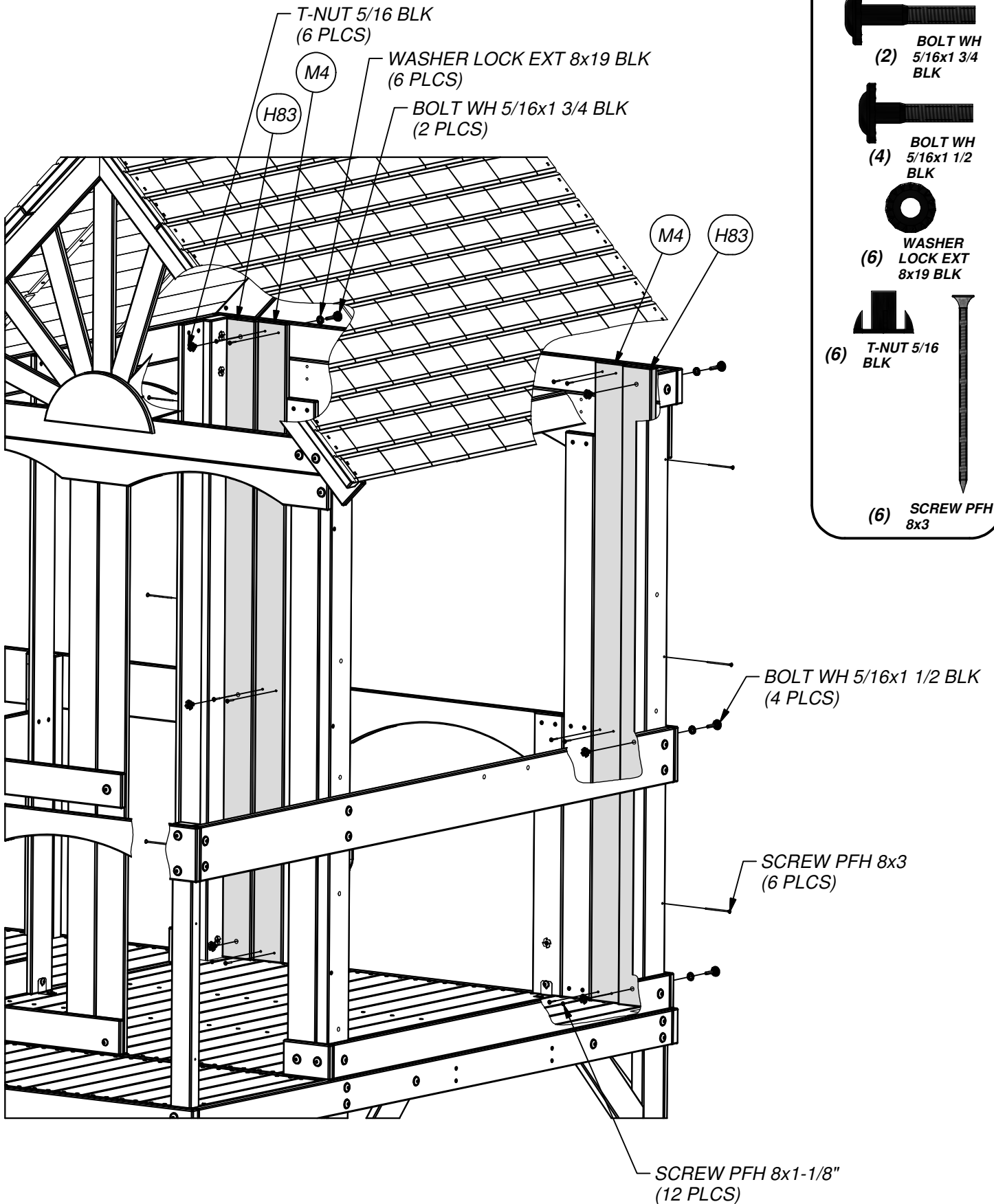



(5) M19 - WALL BOARD - W4L06096
5/8"x3 3/8"x27" (16x86x686)

STEP 54

5 PLCS M19

(20) SCREW PFH
8x1-1/8"

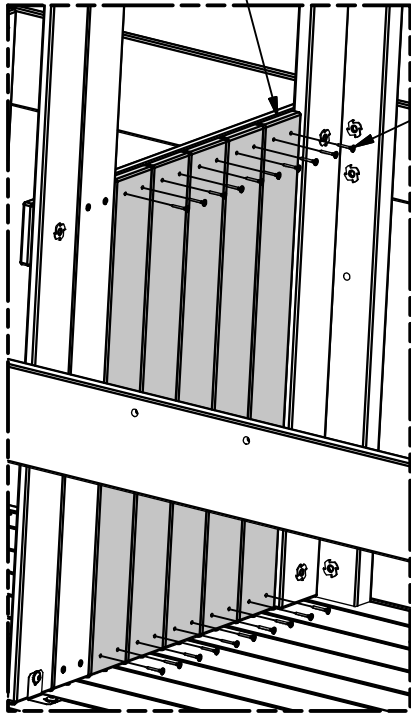

SCREW PFH 8x1-1/8"
(20 PLCS)

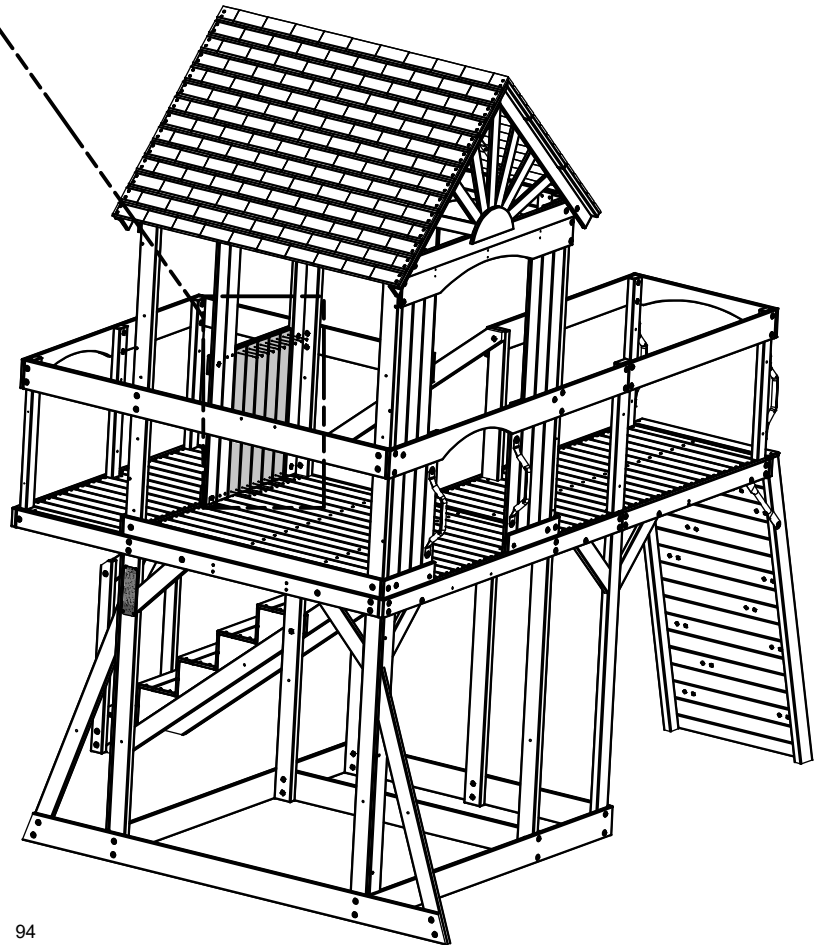

(14) M29 - WALL BOARD - W4L06181
5/8"x3 3/8"x28 5/8" (16x86x726)

STEP 55

SCREW PFH 8x1-1/8"
(56 PLCS)

M29 14 PLCS

(56) SCREW PFH
8x1-1/8"

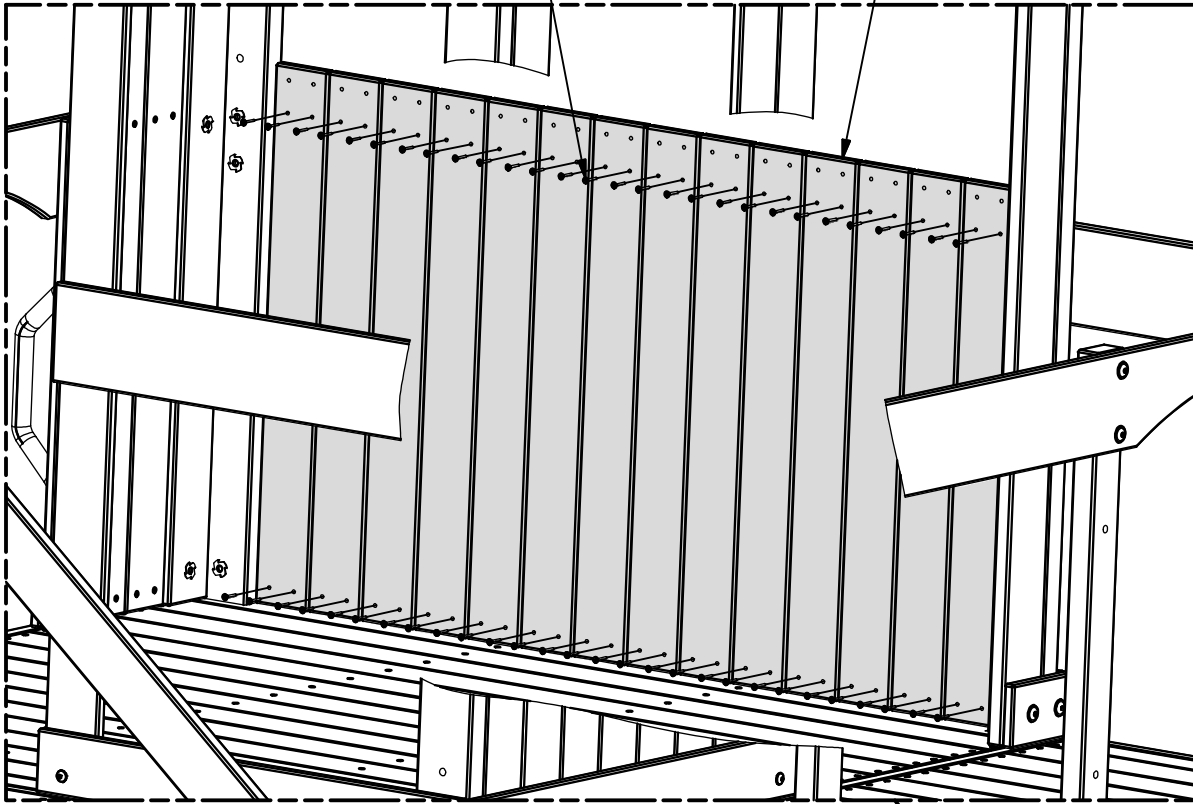

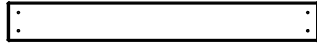

(6) M19 - WALL BOARD - W4L06096
5/8"x3 3/8"x27" (16x86x686)

STEP 56

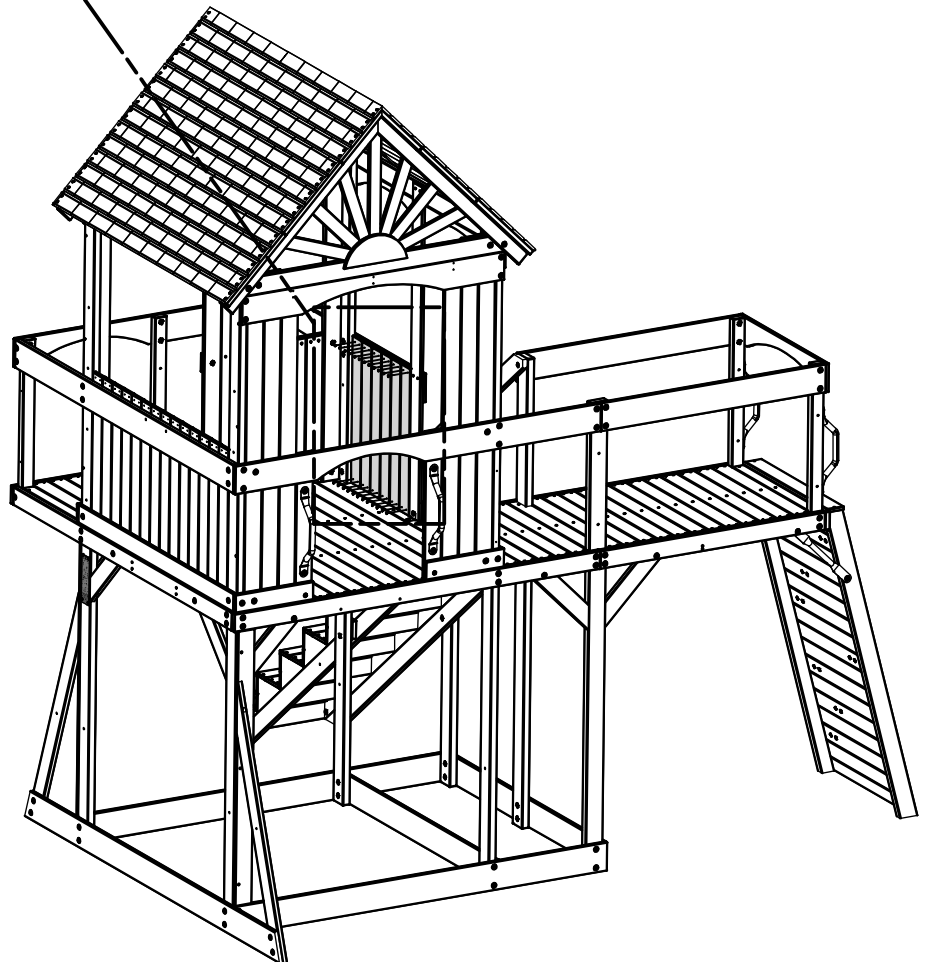
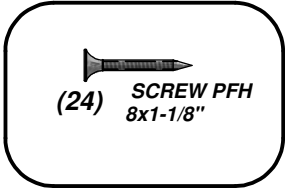
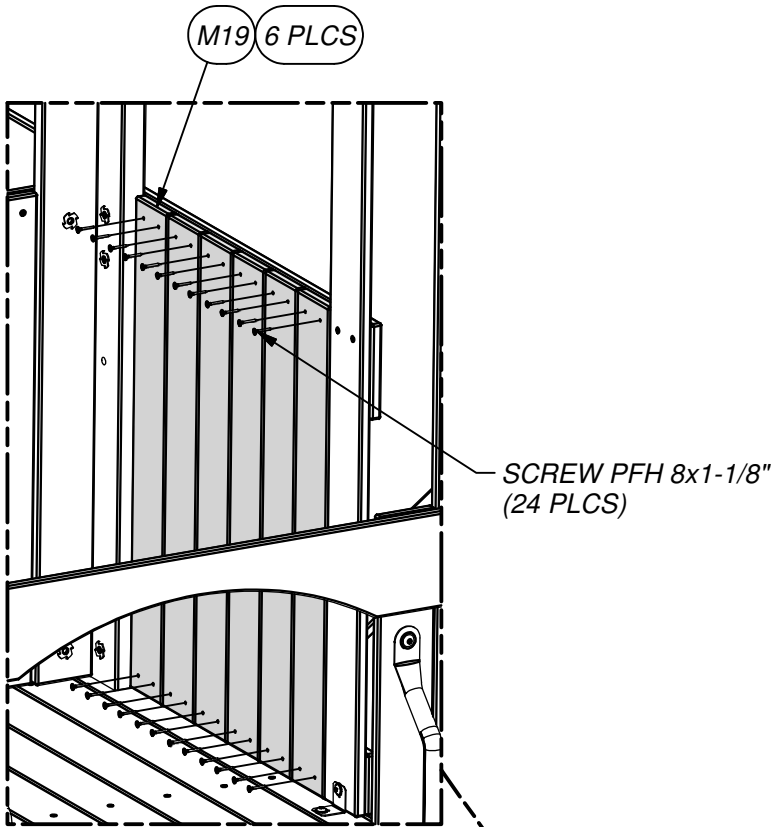

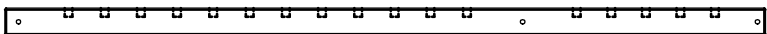

(1) **J7 - WALL RAIL - W4L06192**
1"x2 3/8"x66 1/8" (24x60x1678)

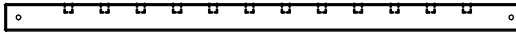

(1) **J11 - WALL RAIL - W4L06324**
1"x2 3/8"x44 5/8" (24x60x1135)

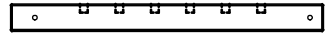

(1) **J3 - WALL RAIL - W4L06092**
1"x2 3/8"x27 1/4" (24x60x691)

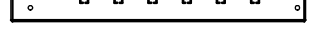

(2) **J6 - WALL RAIL - W4L06089**
1"x2 3/8"x25 5/8" (24x60x650)

STEP 57

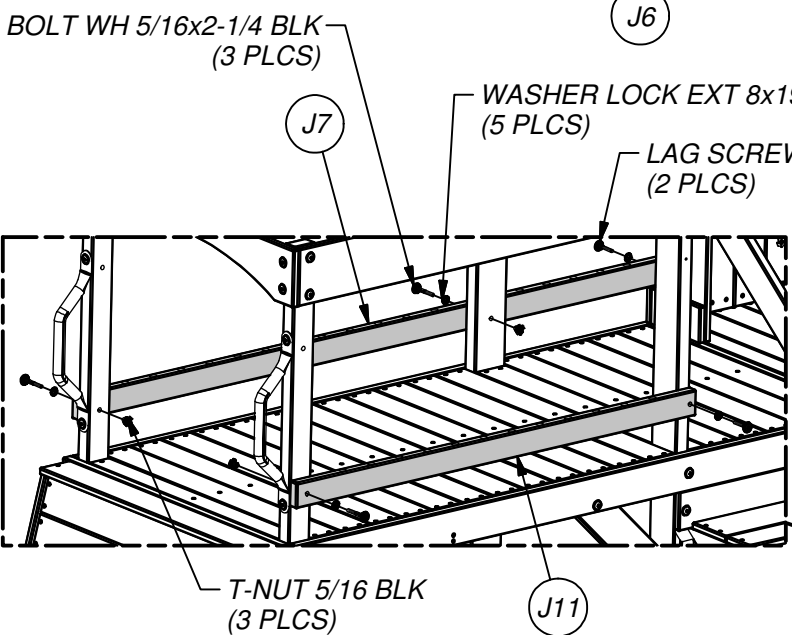
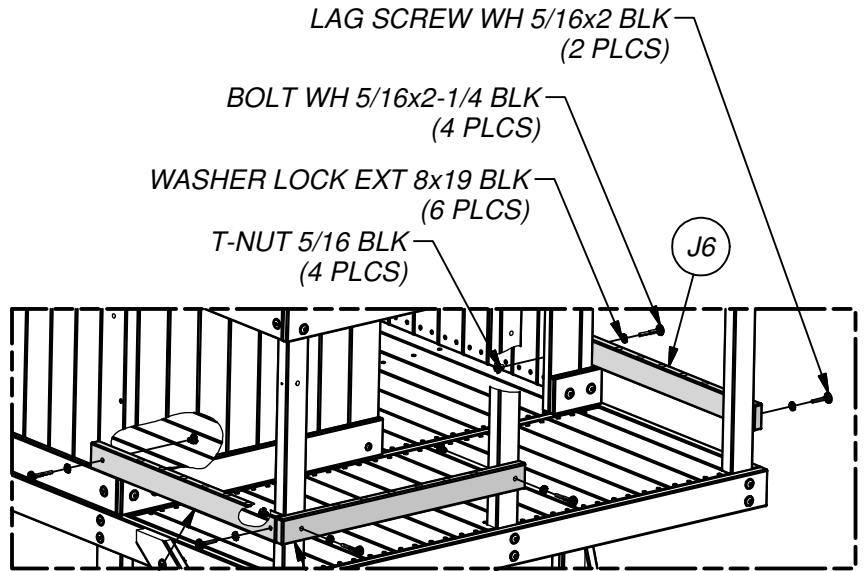
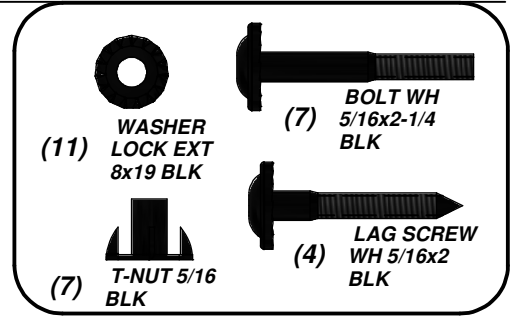

STEP 58

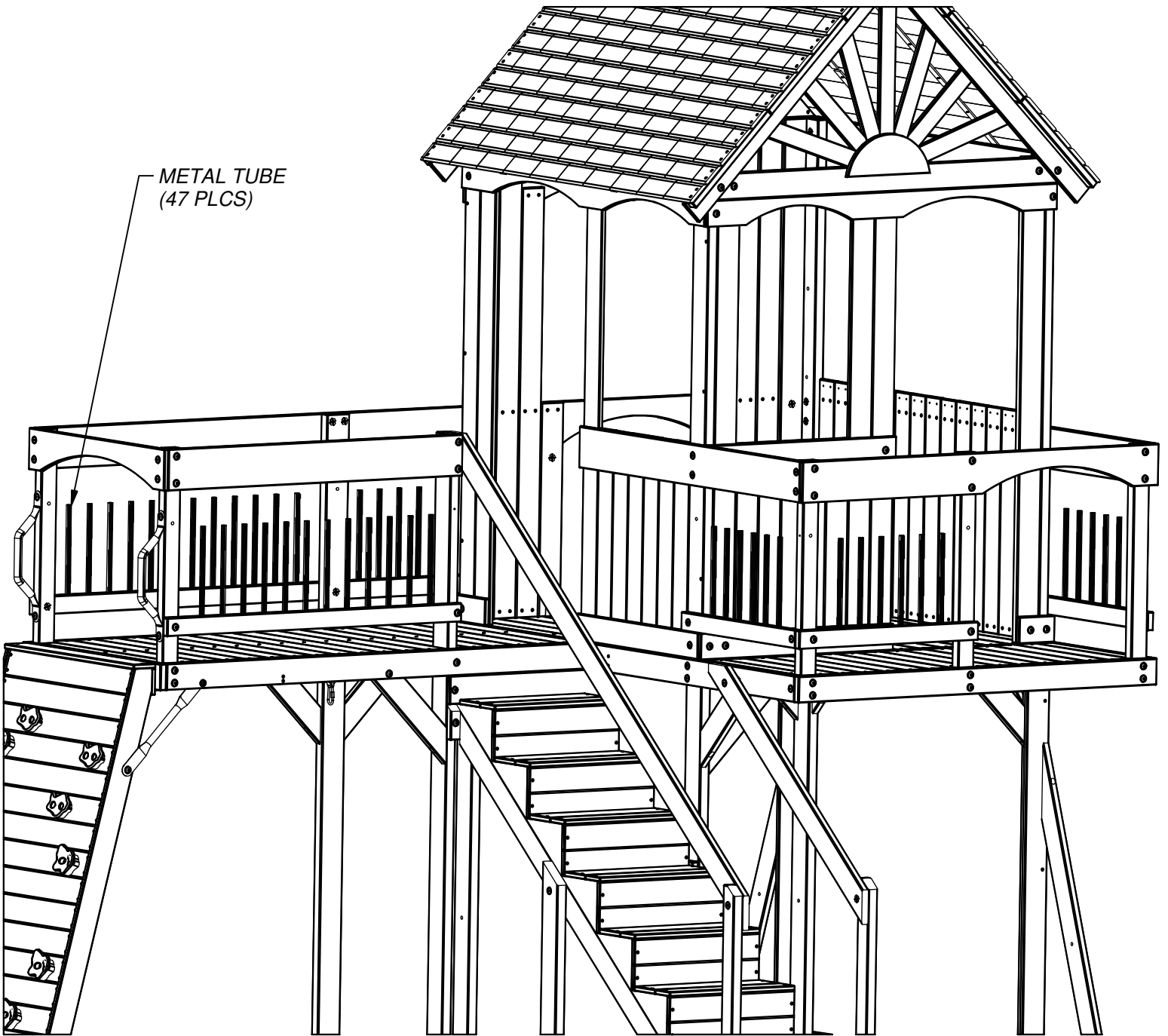

- (1) **J7 - WALL RAIL - W4L06192**
 1"x2 3/8"x66 1/8" (24x60x1678)

- (2) **J6 - WALL RAIL - W4L06089**
 1"x2 3/8"x25 5/8" (24x60x650)

- (1) **J11 - WALL RAIL - W4L06324**
 1"x2 3/8"x44 5/8" (24x60x1135)

- (1) **J3 - WALL RAIL - W4L06092**
 1"x2 3/8"x27 1/4" (24x60x691)

STEP 59

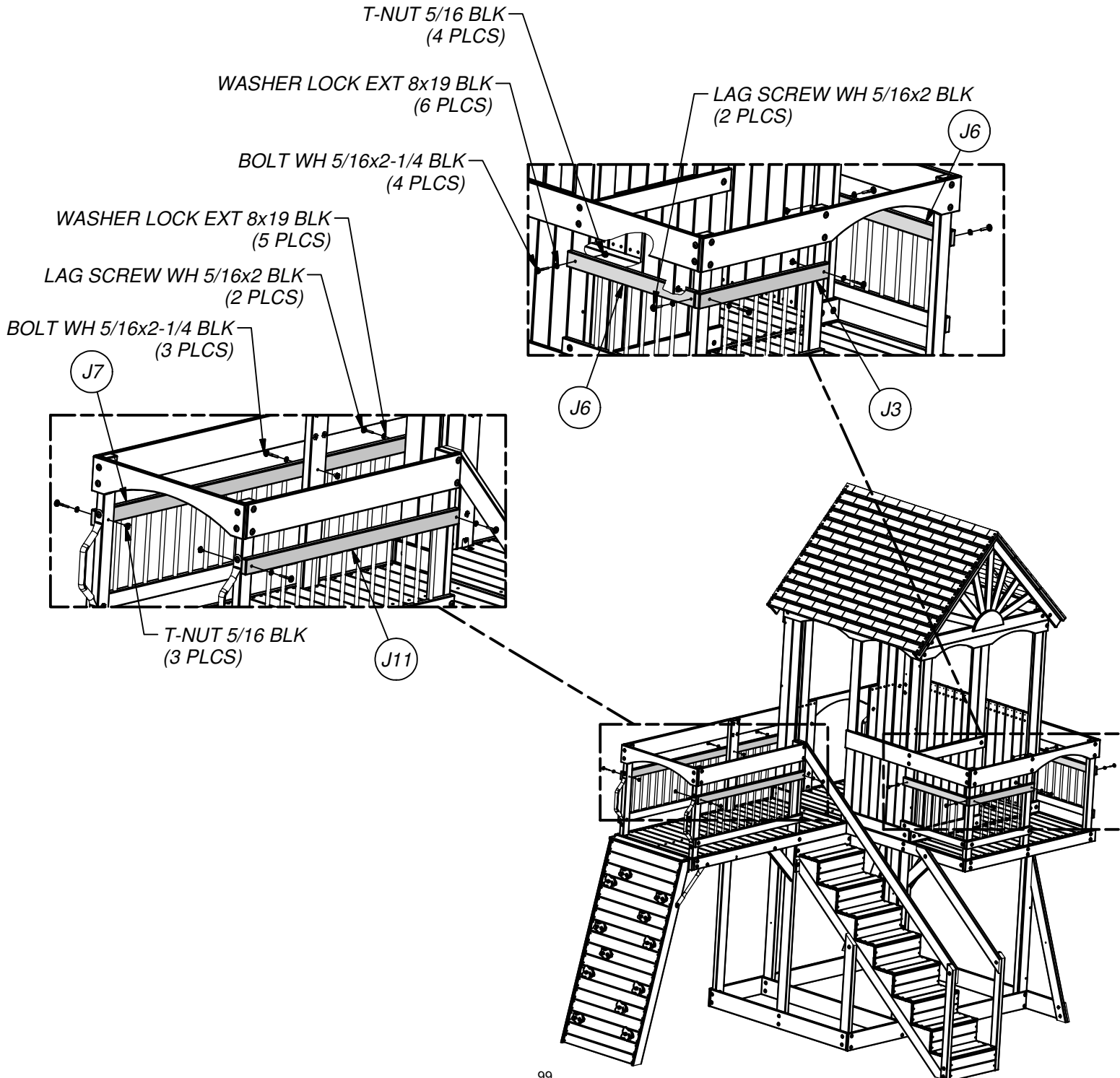
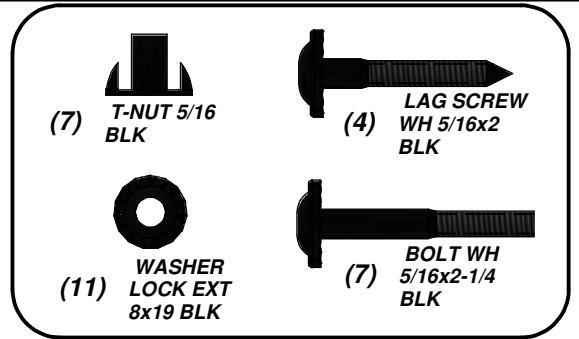

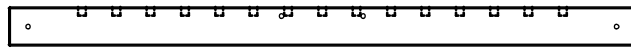

(1) **H6 - WALL RAIL - W4L06088**
1"x3 3/8"x54 1/2" (24x86x1384)

STEP 60

- T-NUT 5/16 BLK (4 PLCS)
- SCREW PFH 8x1-1/8" (28 PLCS)

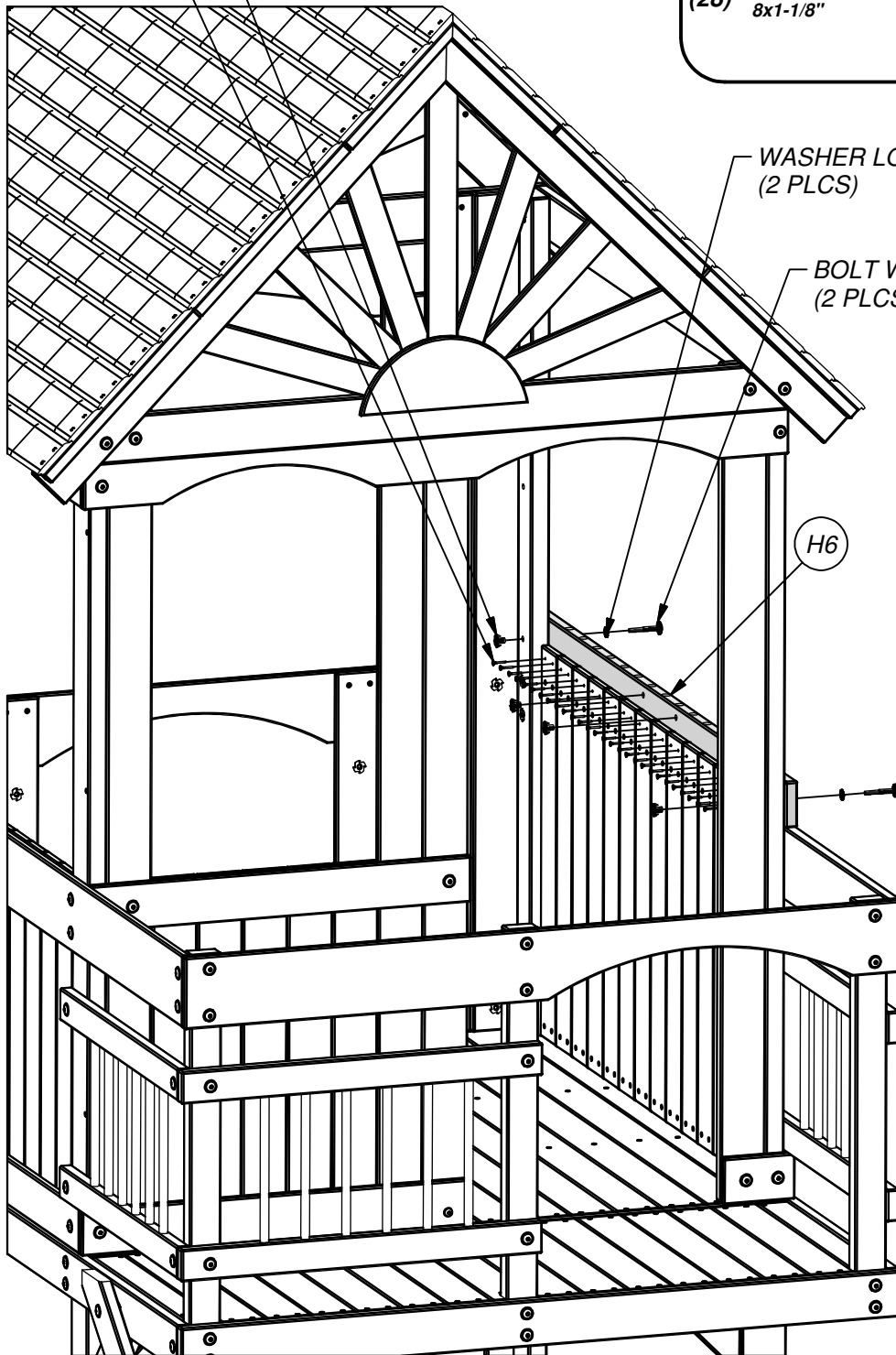
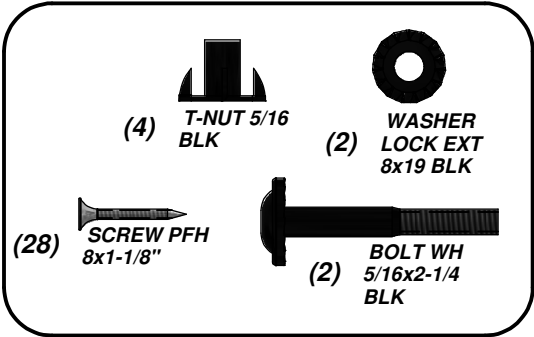

- WASHER LOCK EXT 8x19 BLK (2 PLCS)

- BOLT WH 5/16x2-1/4 BLK (2 PLCS)

H6

(15) - METAL TUBE - A4M00620

STEP 61

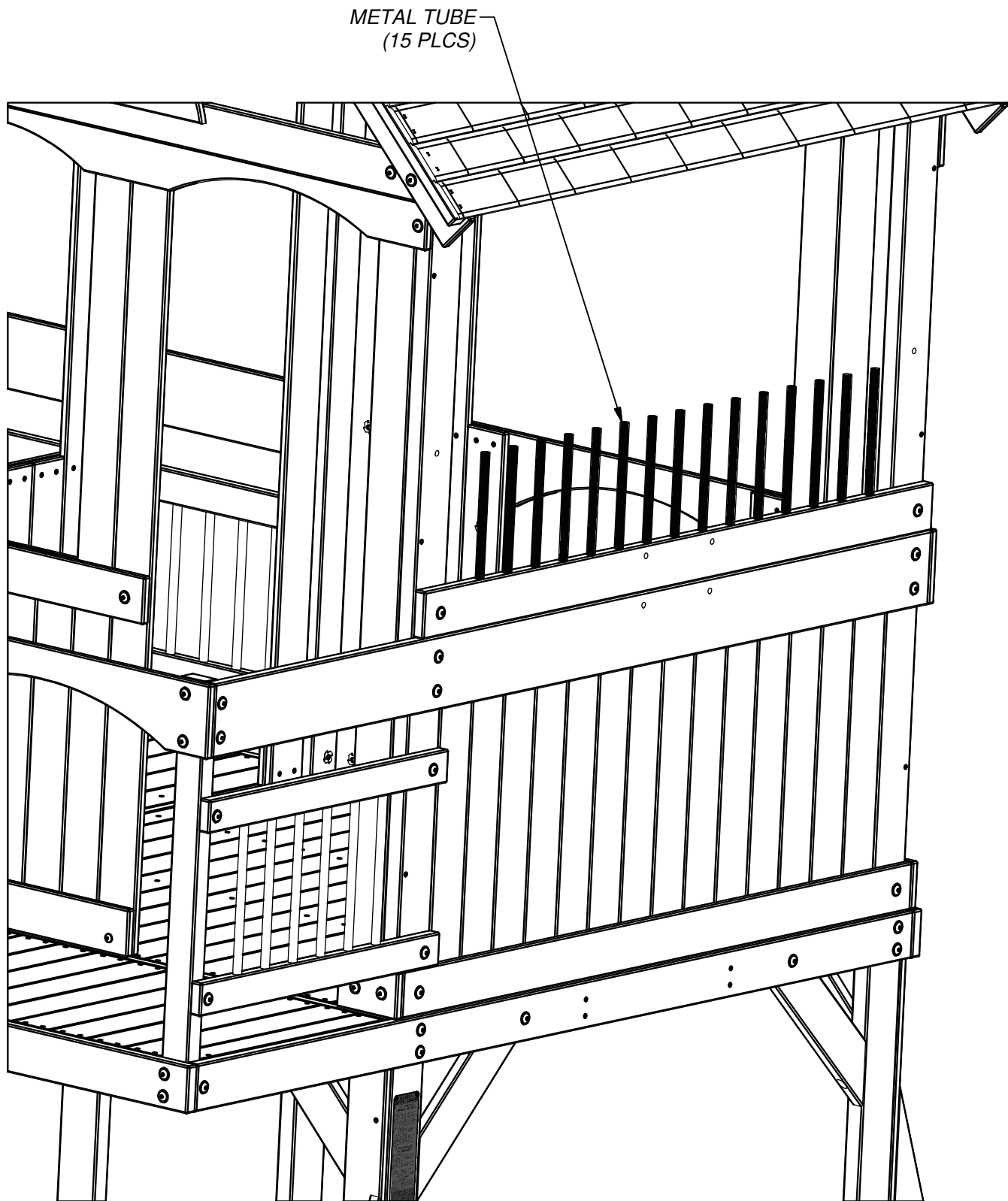

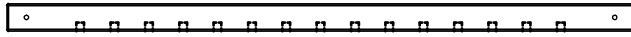

(1) J1 - WALL RAIL - W4L06104
1"x2 3/8"x54 1/2" (24x60x1384)

STEP 62

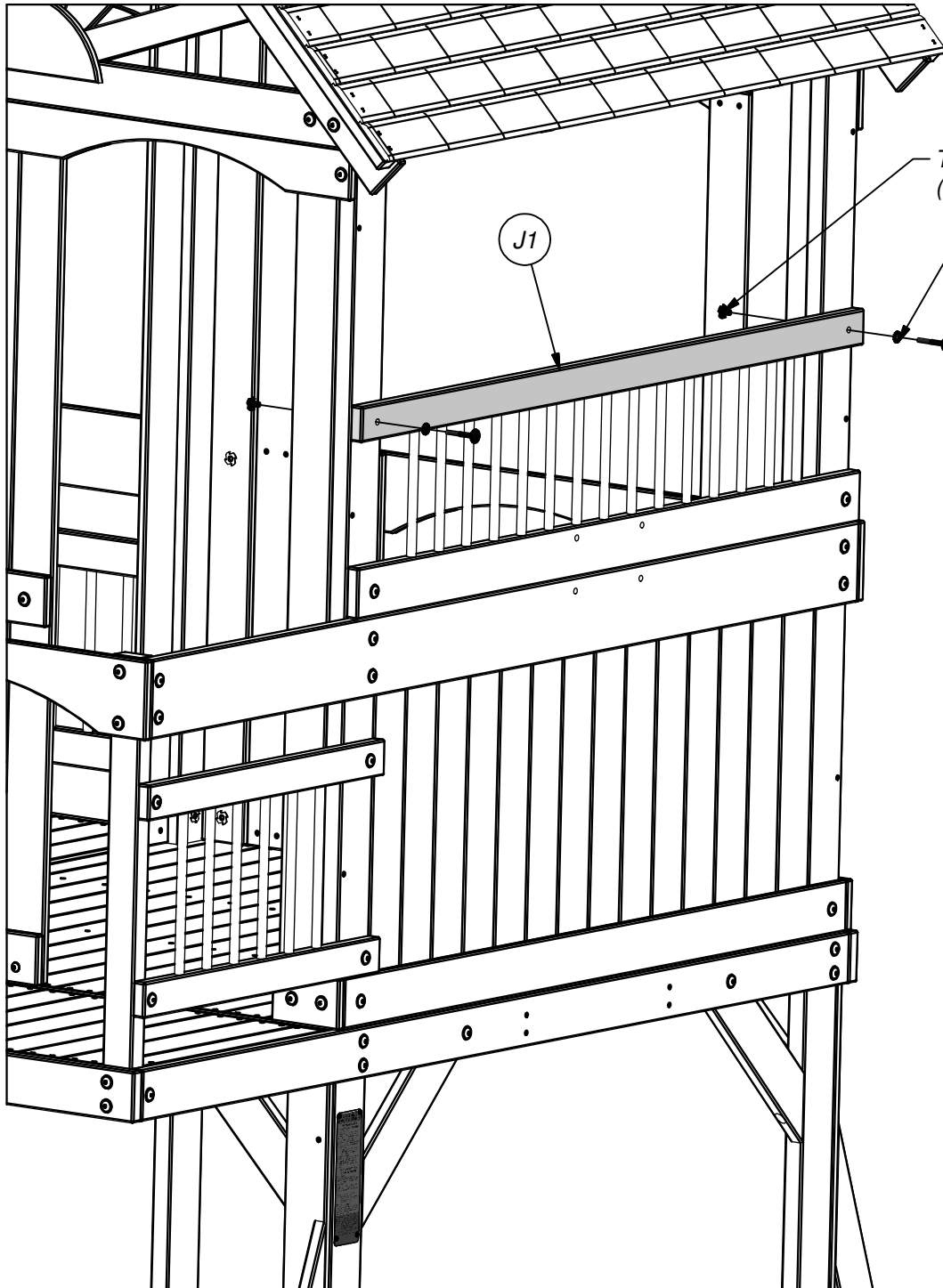
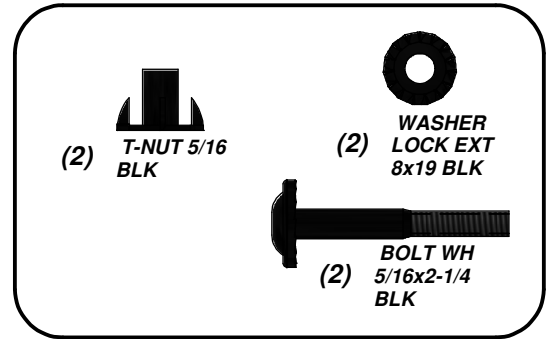

T-NUT 5/16 BLK
(2 PLCS)

WASHER LOCK EXT 8x19 BLK
(2 PLCS)

BOLT WH 5/16x2-1/4 BLK
(2 PLCS)

O1 - PICKET - W4L06135
(15) 5/8"x1 3/8"x31 1/4" (16x34x795)

STEP 63

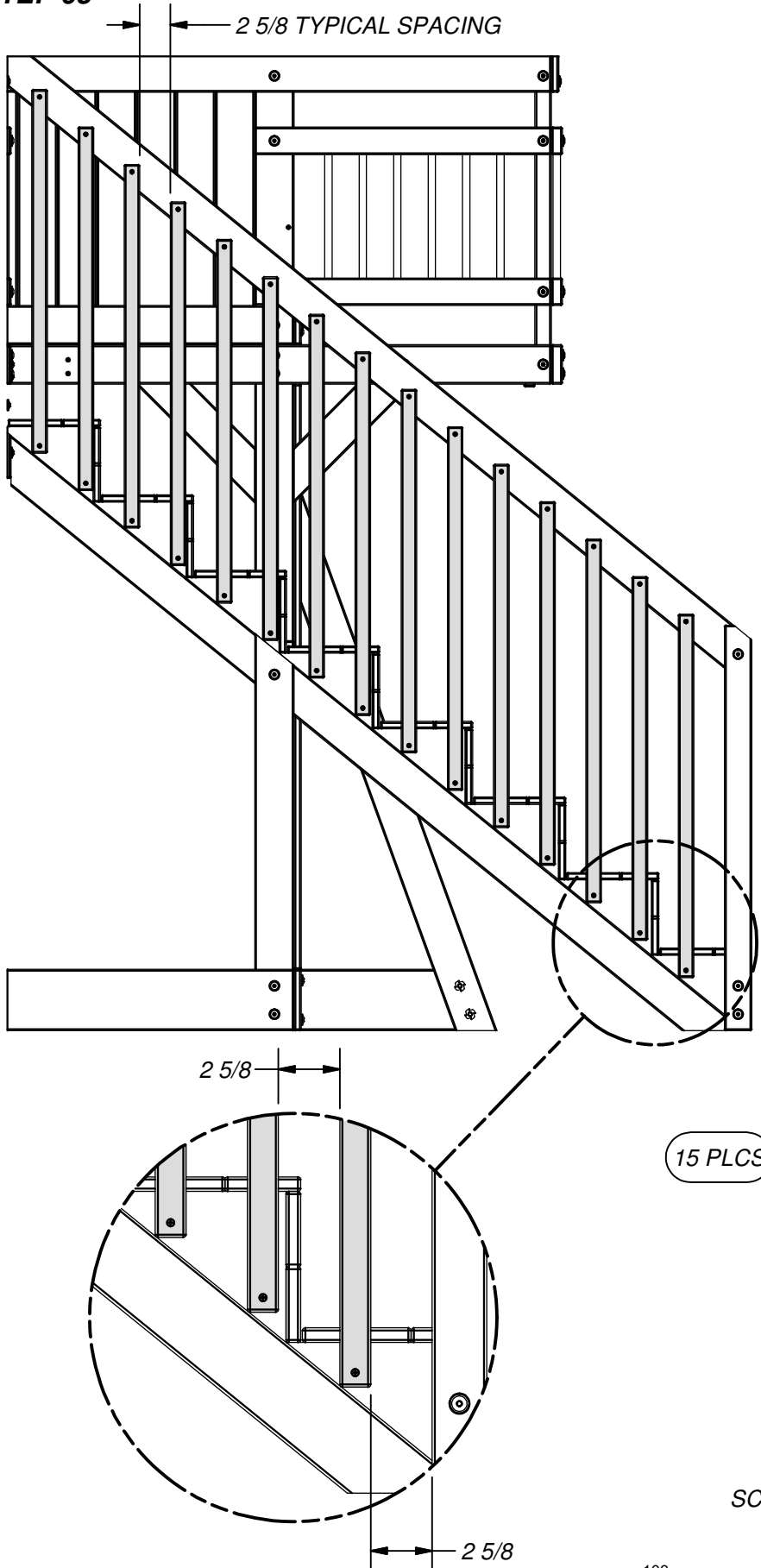

(30) SCREW PFH
8x1-1/4"

15 PLCS O1

SCREW PFH 8x1-1/4"
(30 PLCS)

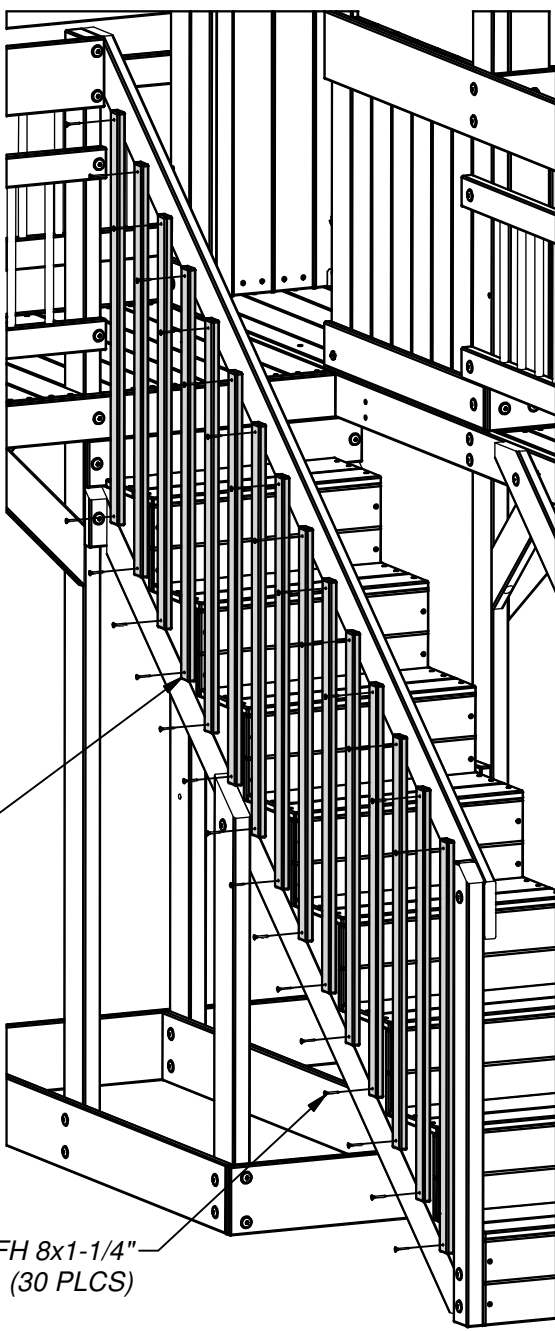

(7) O1 - PICKET - W4L06135
5/8"x1 3/8"x31 1/4" (16x34x795)

STEP 64

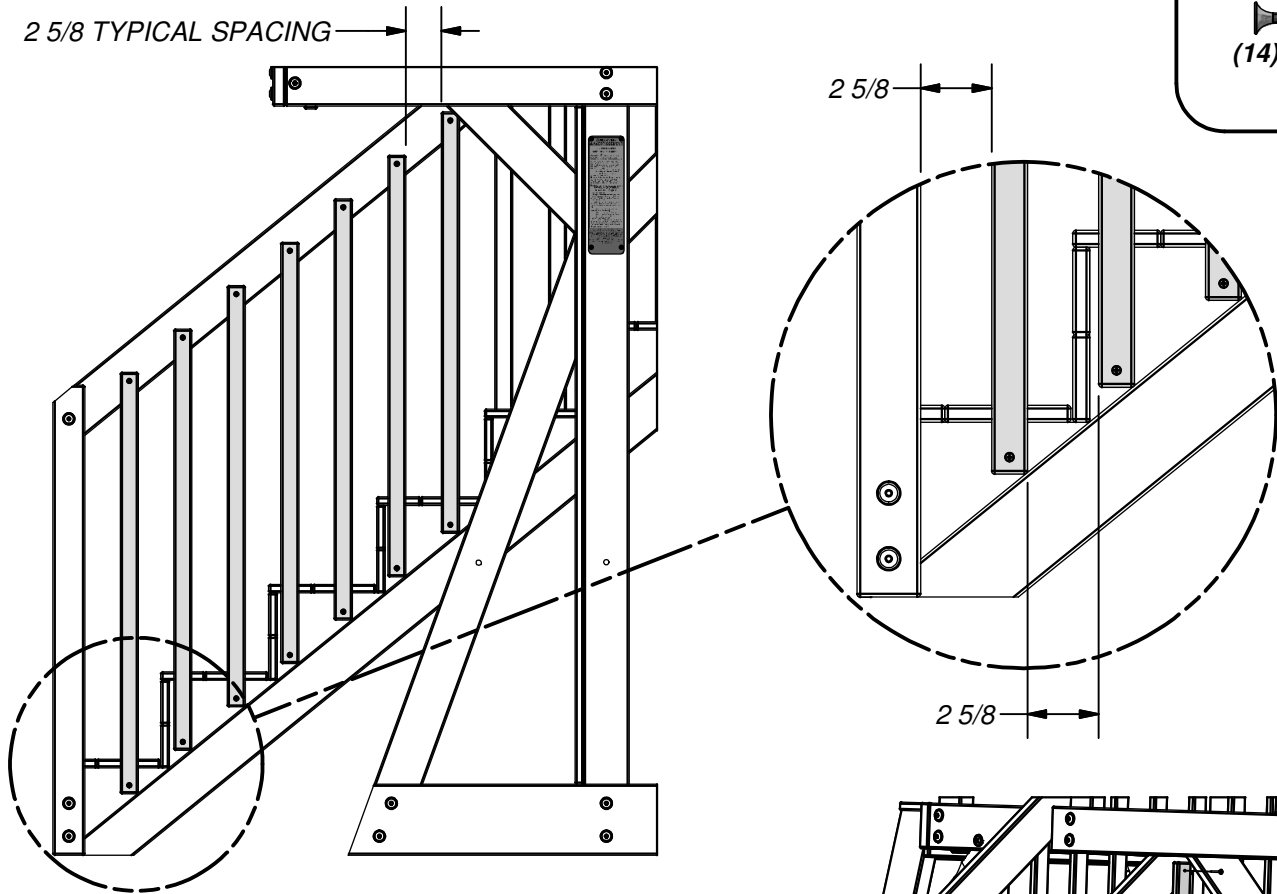
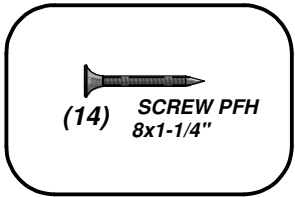

7 PLCS O1

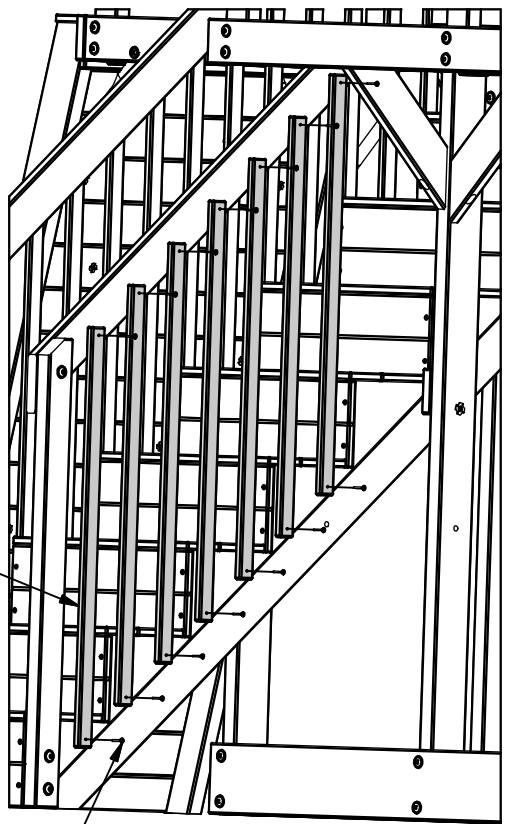

SCREW PFH 8x1-1/4"
(14 PLCS)

(1) T3 - PICKET - W4L06136
1"x1 3/8"x27 1/8" (24x34x688)

(1) T6 - PICKET - W4L06137
1"x1 3/8"x19 5/8" (24x34x500)

STEP 65

(4) SCREW PFH
8x1-1/2"

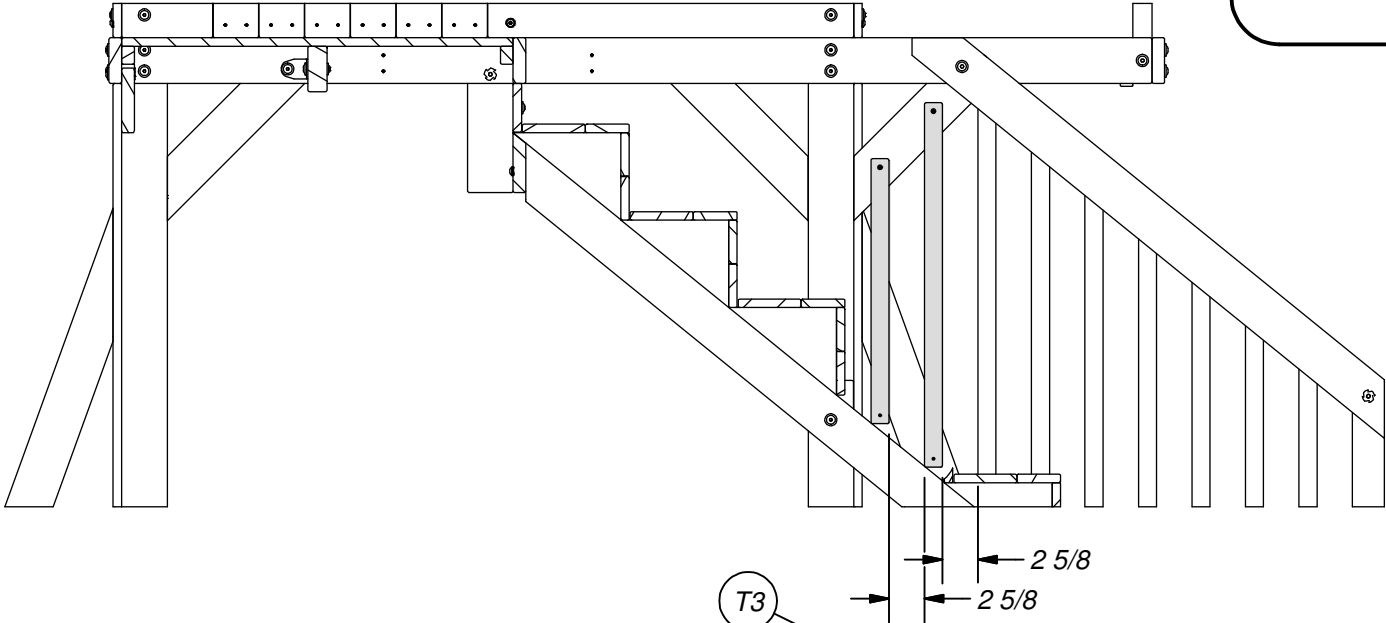

SCREW PFH 8x1-1/2"
(4 PLCS)

(1) T7 - PICKET - W4L06138
1"x1 3/8"x18 3/8" (24x34x468)

(1) T9 - PICKET - W4L06139
1"x1 3/8"x15 1/4" (24x34x386)

(1) T11 - PICKET - W4L06141
1"x1 3/8"x8 3/4" (24x34x222)

(1) L2 - SUPPORT BOARD - W4L06142
5/8"x4 3/8"x15 5/8" (16x112x397)

(1) T10 - PICKET - W4L06140
1"x1 3/8"x12" (24x34x304)

STEP 66

(4) SCREW PFH
8x1-1/2"

(6) SCREW PFH
8x1-1/4"

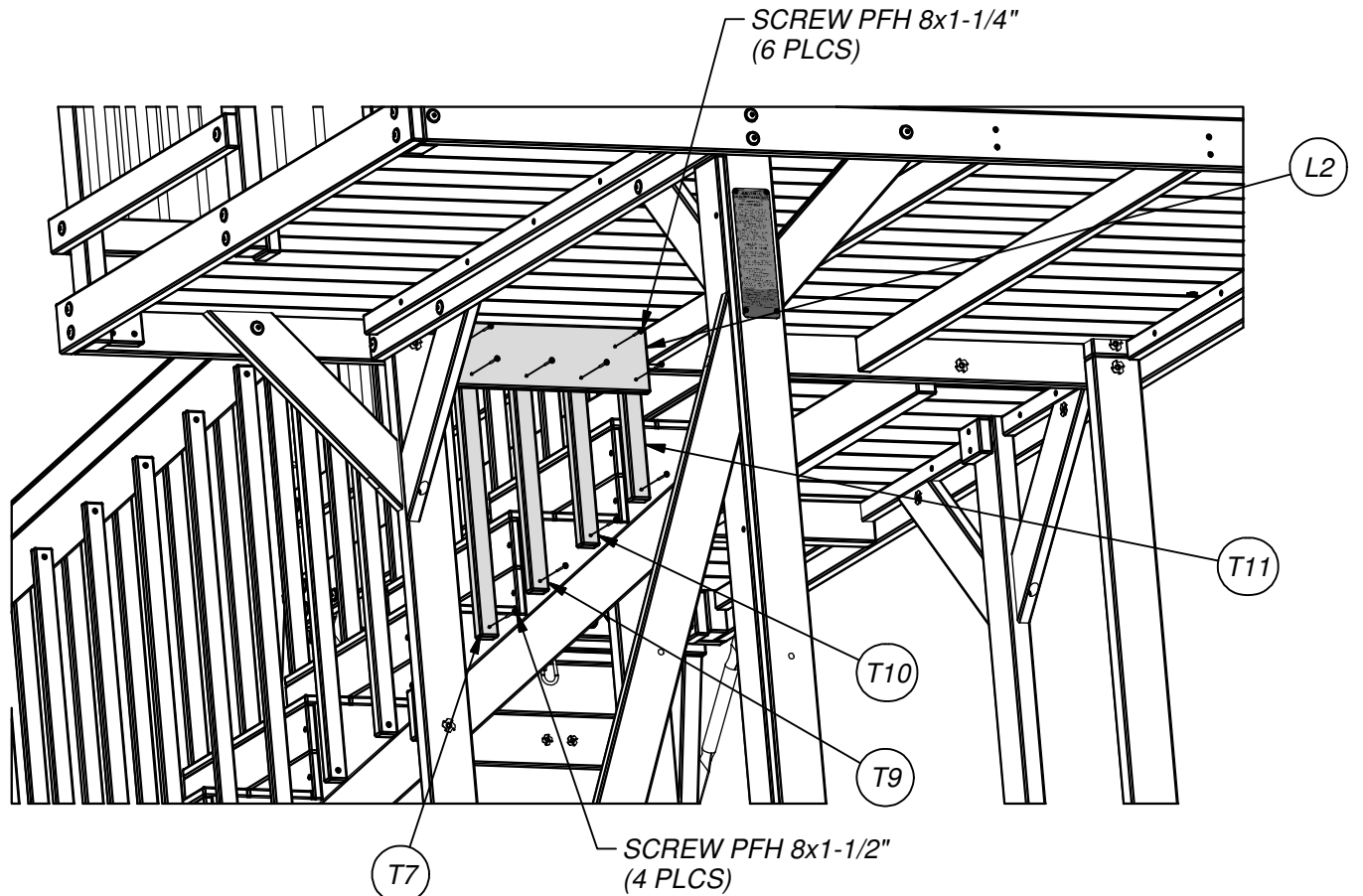
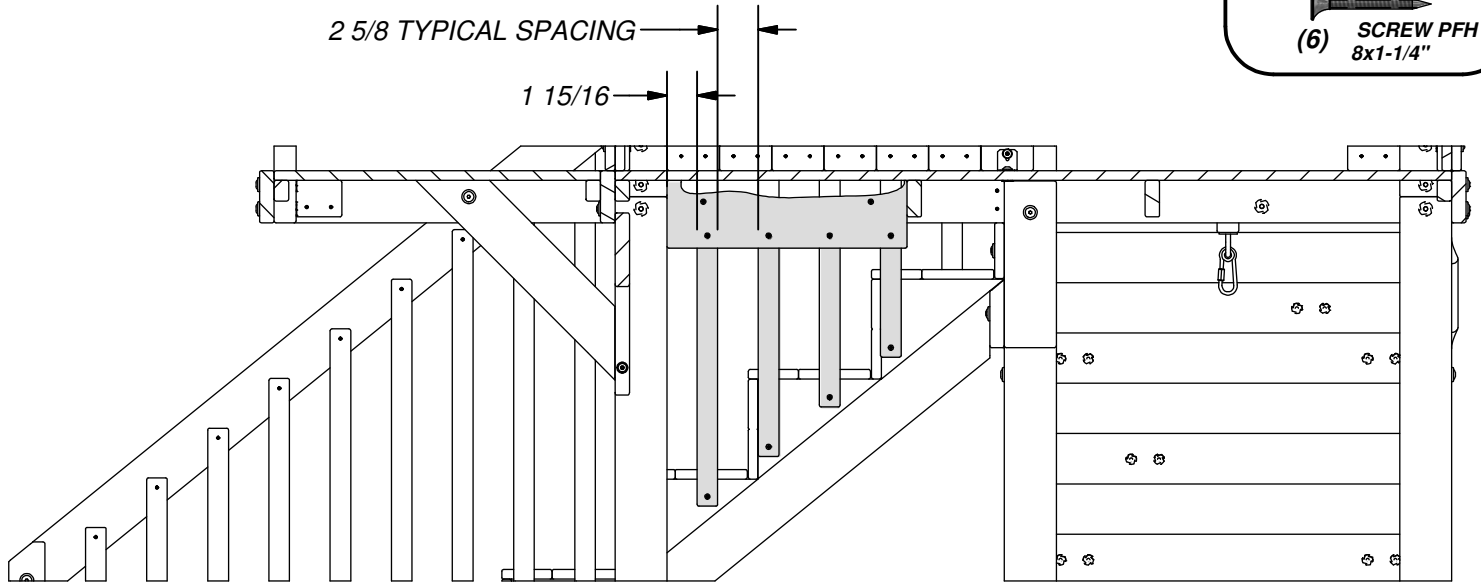

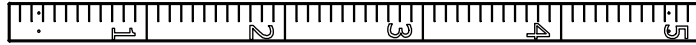

(1) **M1 - GROWTH BOARD - W4L06143**
5/8"x3 3/8"x60 1/4" (16x86x1530)

STEP 67

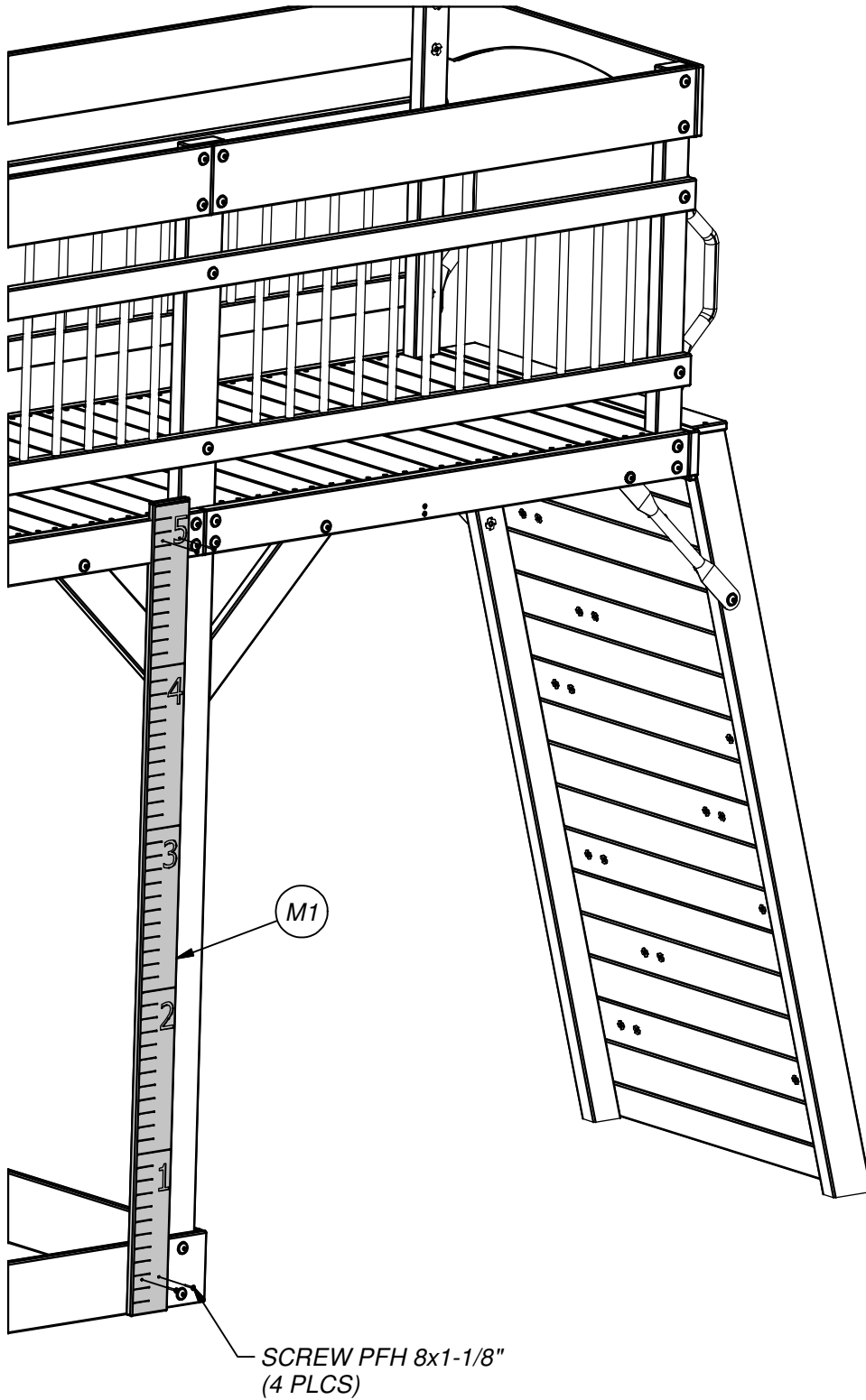
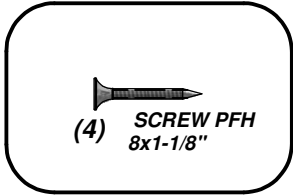

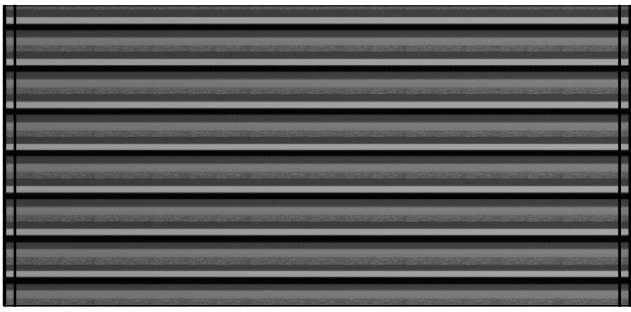

(1) - HAMMOCK - A6P00066

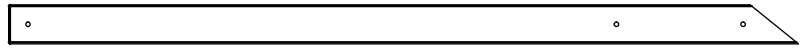

(1) H5 - SAFETY RAIL - W4L06059
1"x3 3/8"x68 5/8" (24x86x1742)

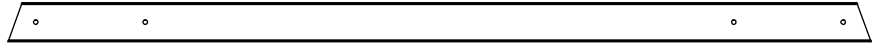

(1) H85 - SAFETY RAIL - W4L06184
1"x3 3/8"x75" (24x86x1904)

STEP 68

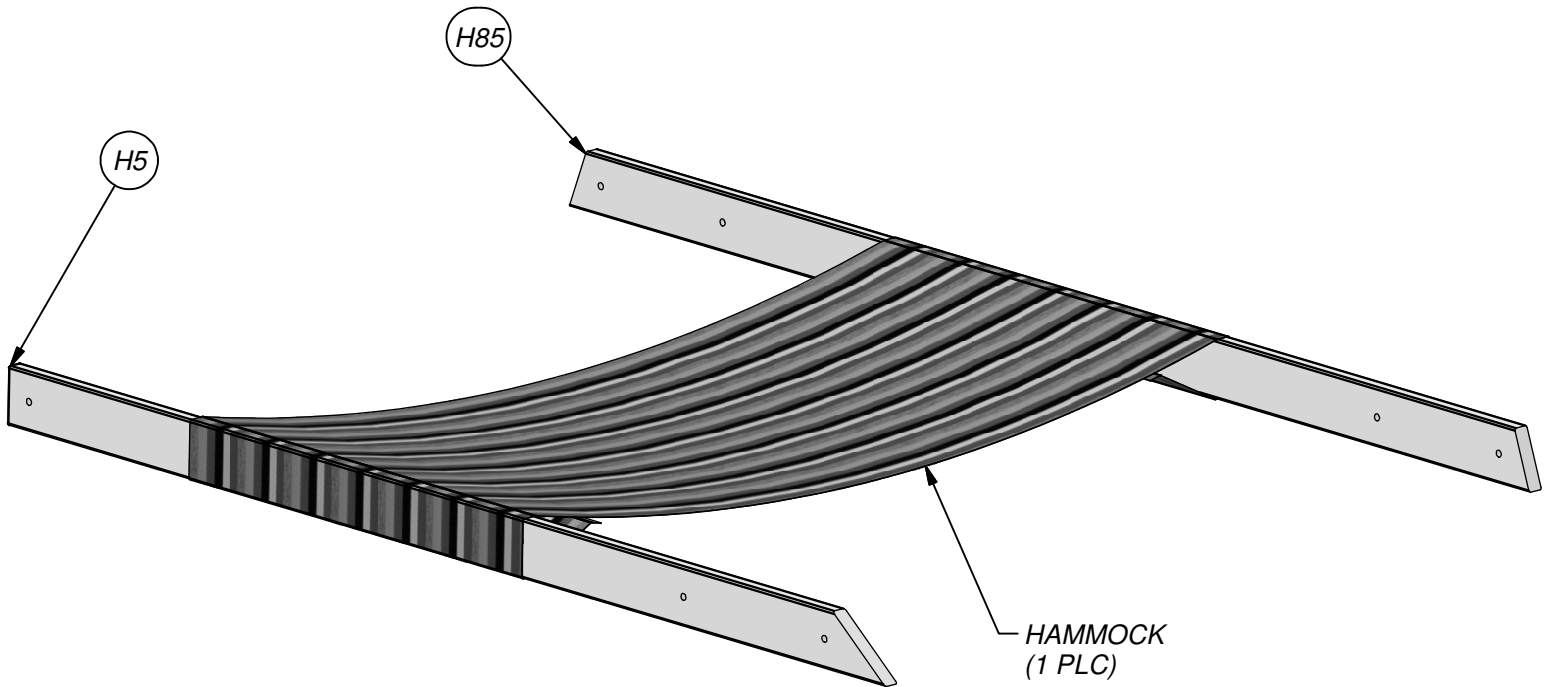

STEP 69

NOTE:

BACKYARD DISCOVERY RECOMMENDS NO MORE THAN 150 POUNDS ON THE HAMMOCK.

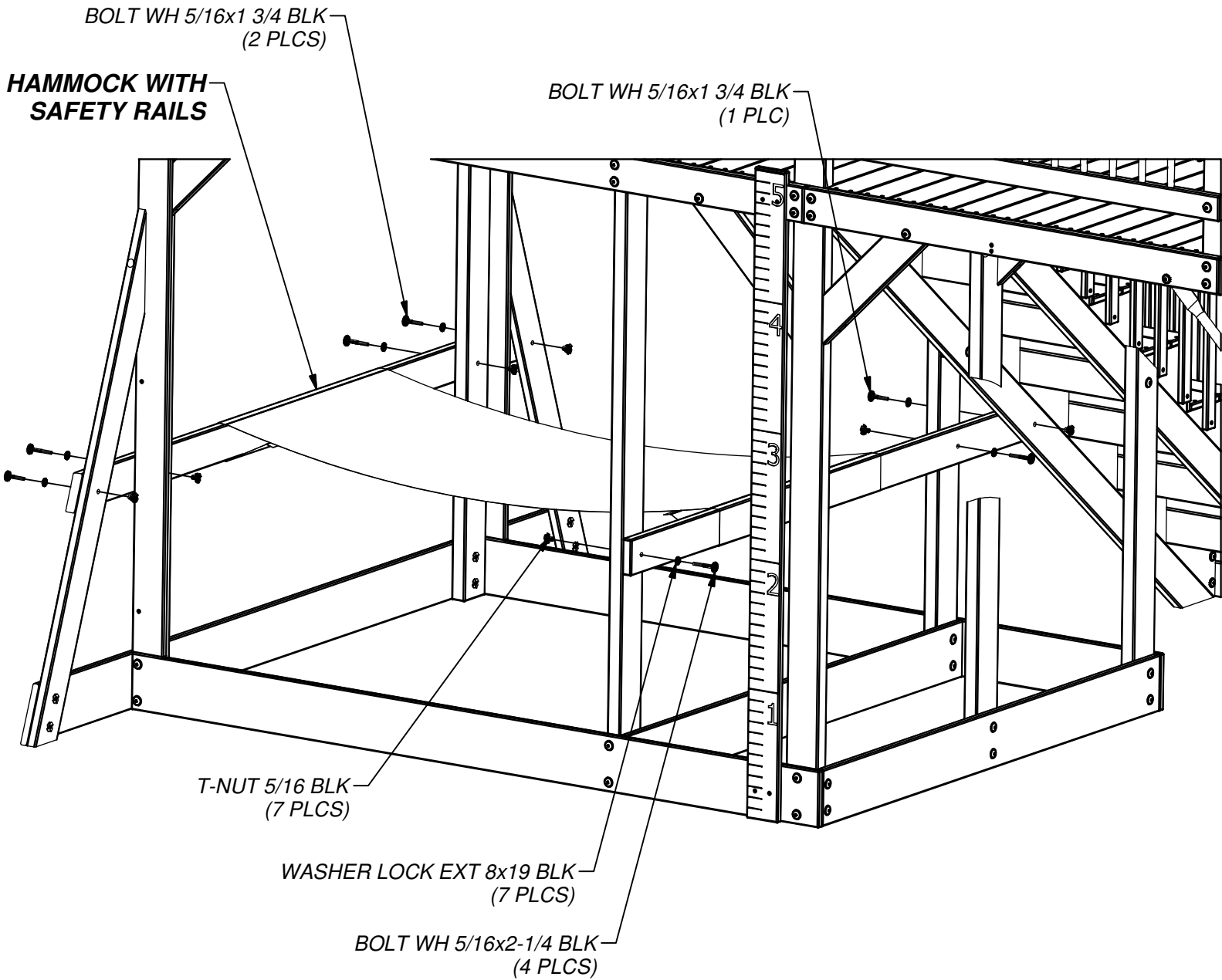
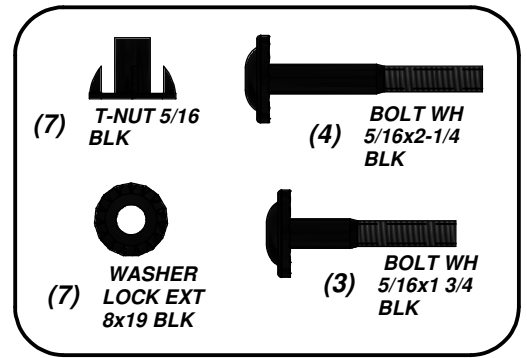



(2) **J4 - OUTER CURTAIN ROD HOLDER - W4L05293**
1"x2 3/8"x2 3/8" (24x60x60)



(1) **J5 - INNER CURTAIN ROD HOLDER - W4L05294**
1"x2 3/8"x2 3/8" (24x60x60)

STEP 70

(6) SCREW PFH
8x1-3/4"

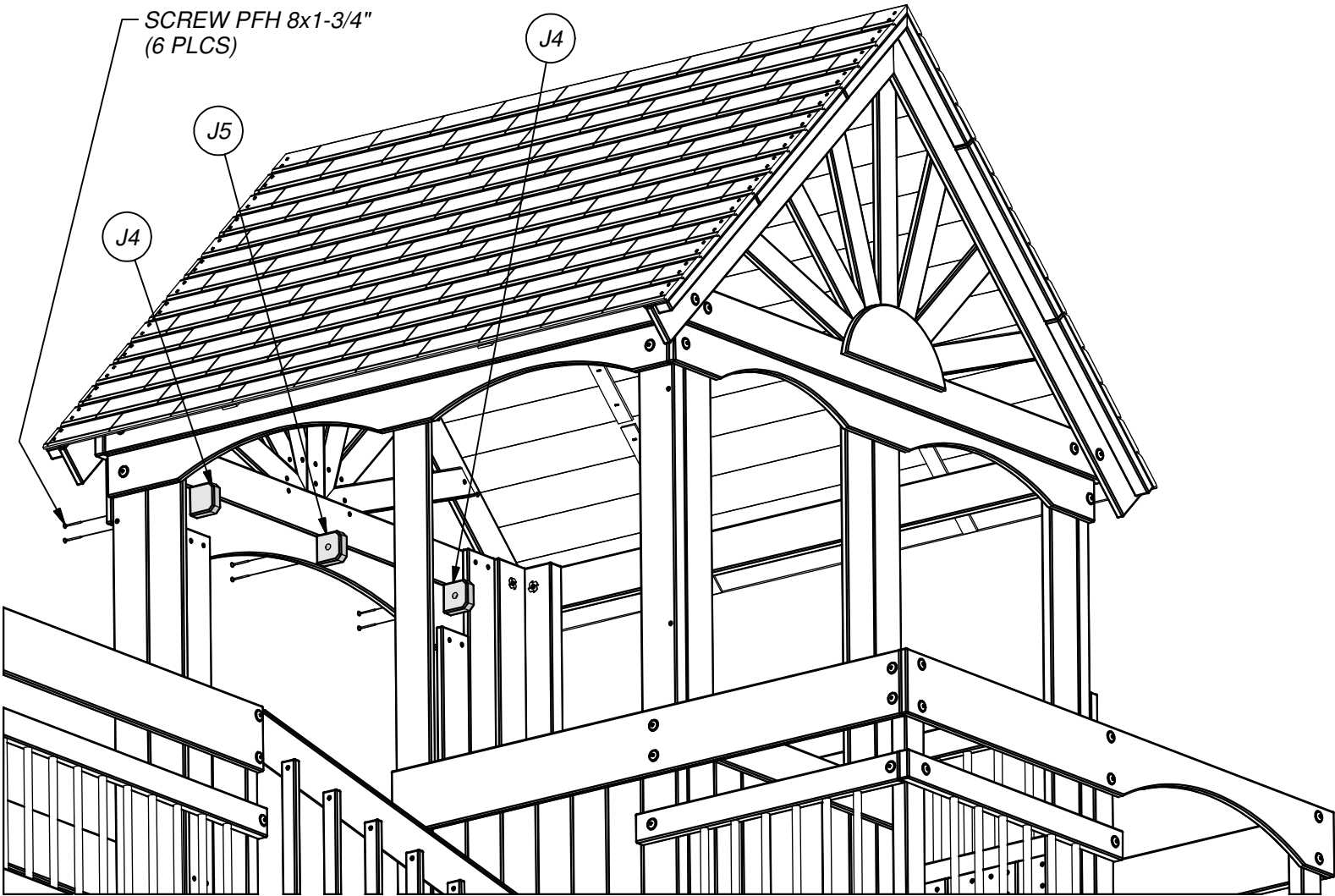

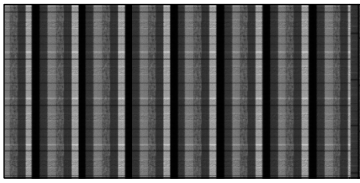

(1) - CURTAIN - A6P00089

(1) - PLASTIC CURTAIN ROD - A6P00090

STEP 71

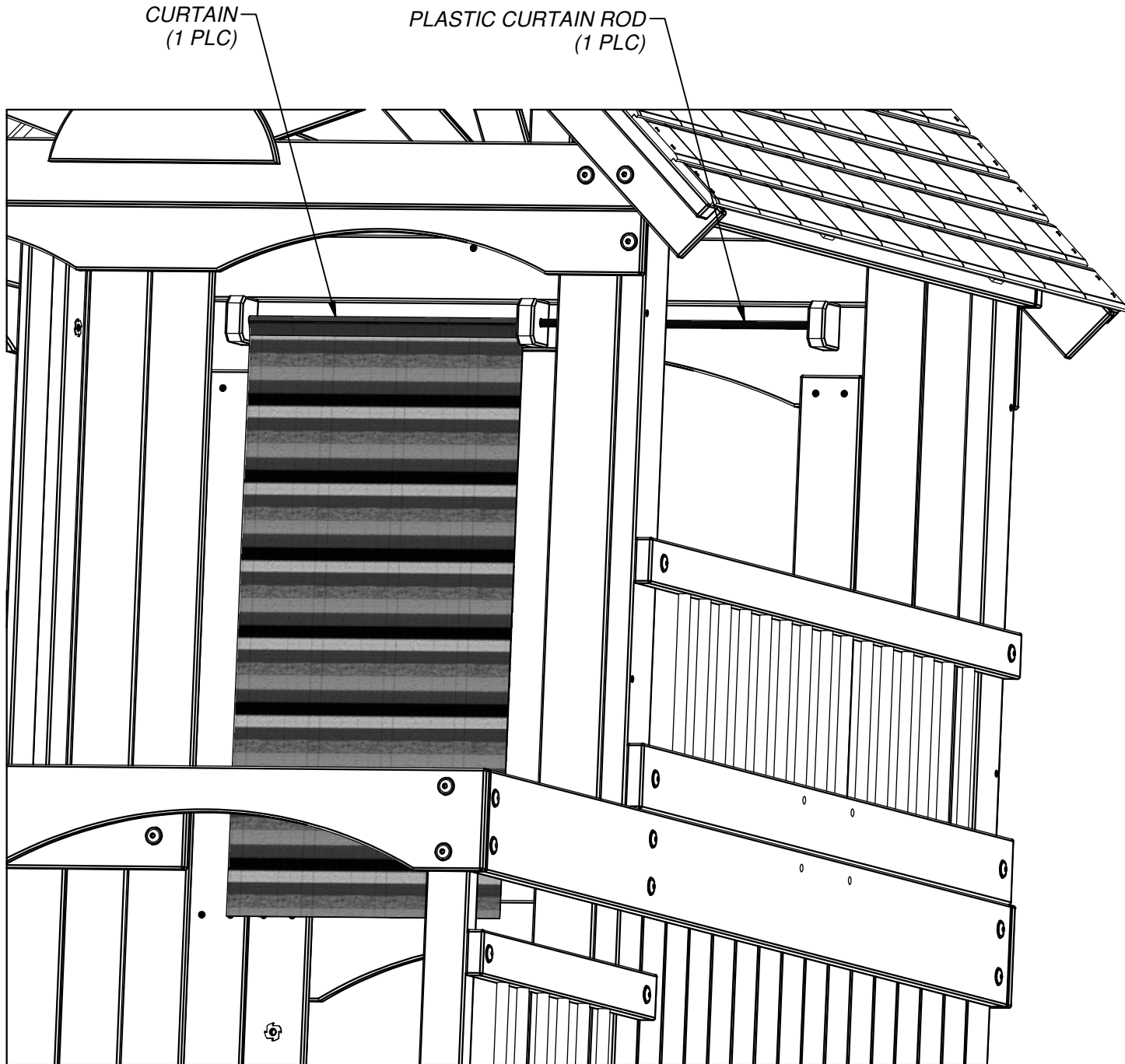

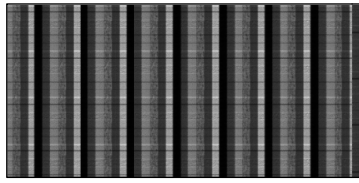

(1) - CURTAIN - A6P00089

STEP 72

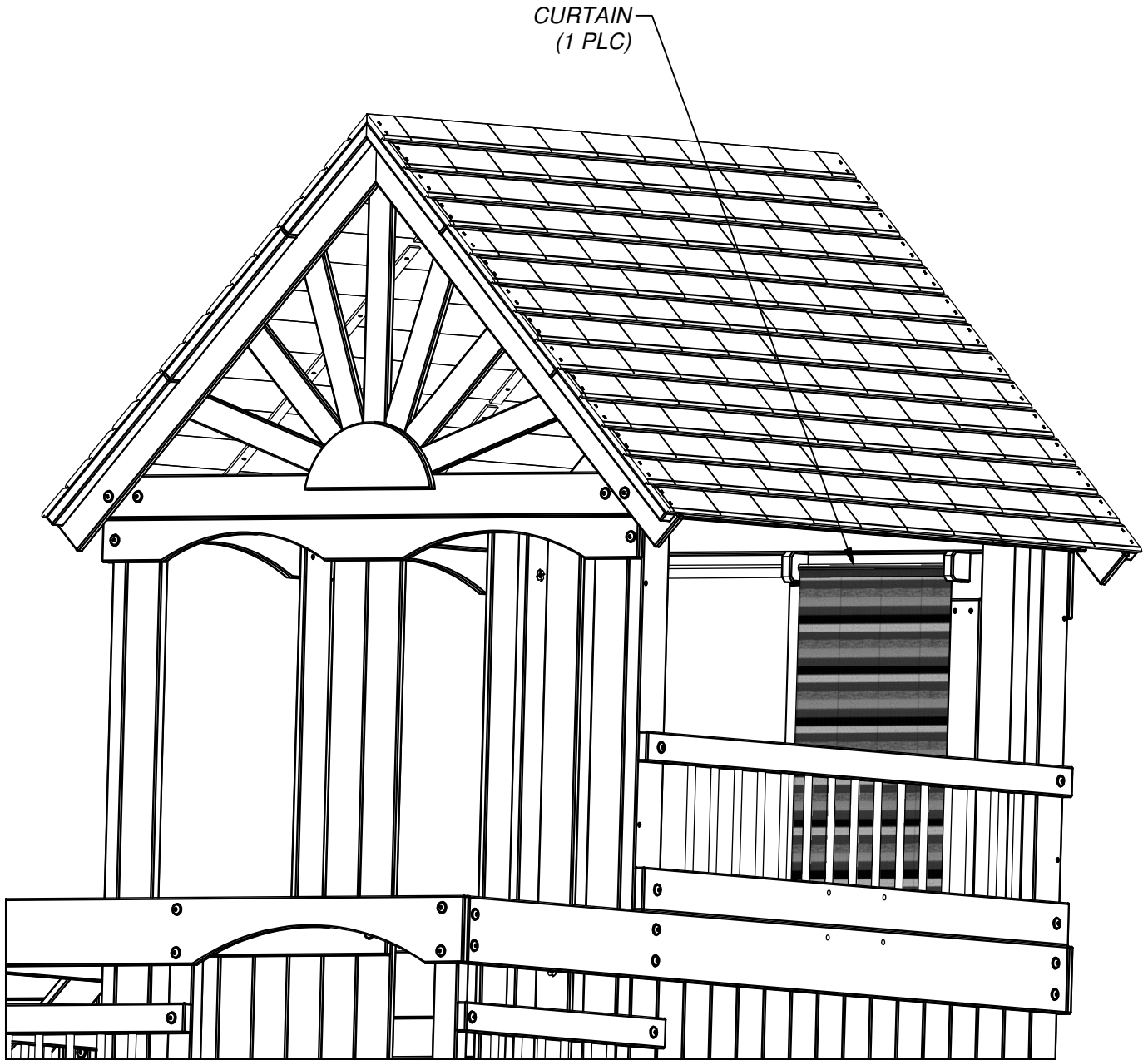

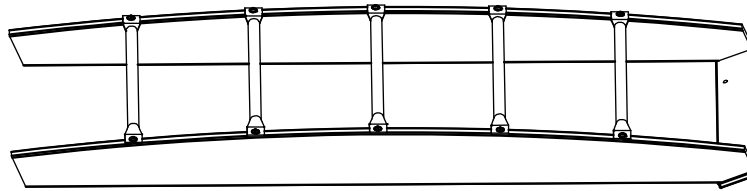

LADDER ASSEMBLY

STEP 73

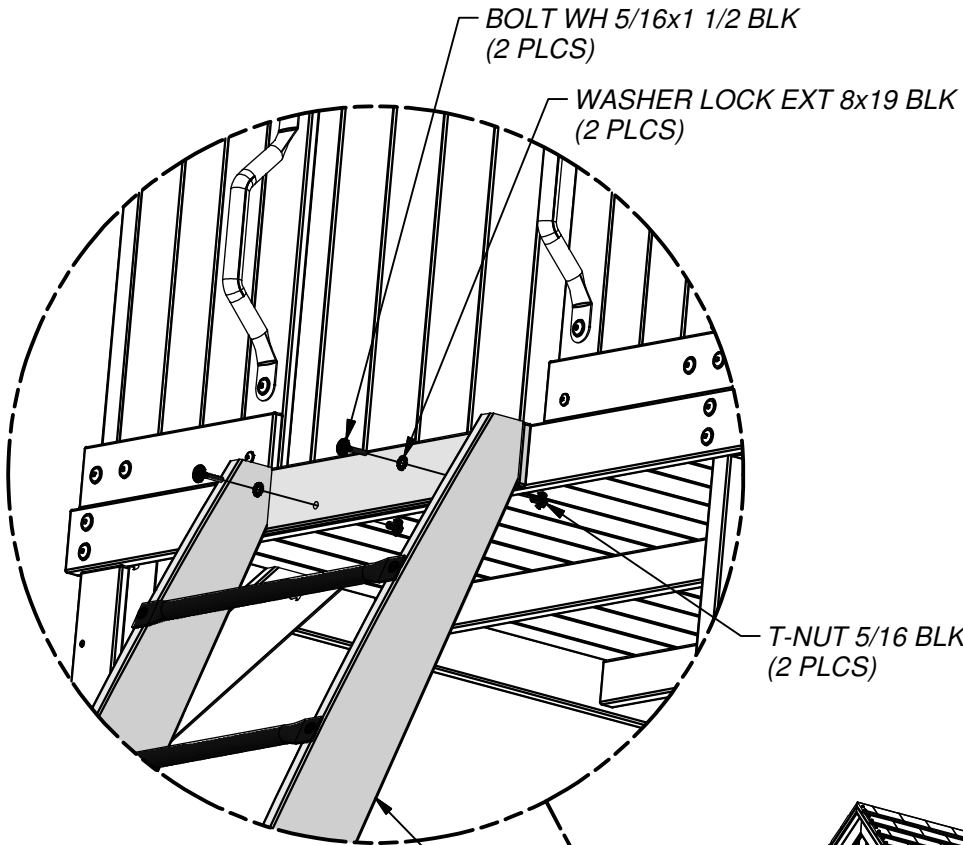

BOLT WH 5/16x1 1/2 BLK
(2 PLCS)

WASHER LOCK EXT 8x19 BLK
(2 PLCS)

T-NUT 5/16 BLK
(2 PLCS)

LADDER ASSEMBLY

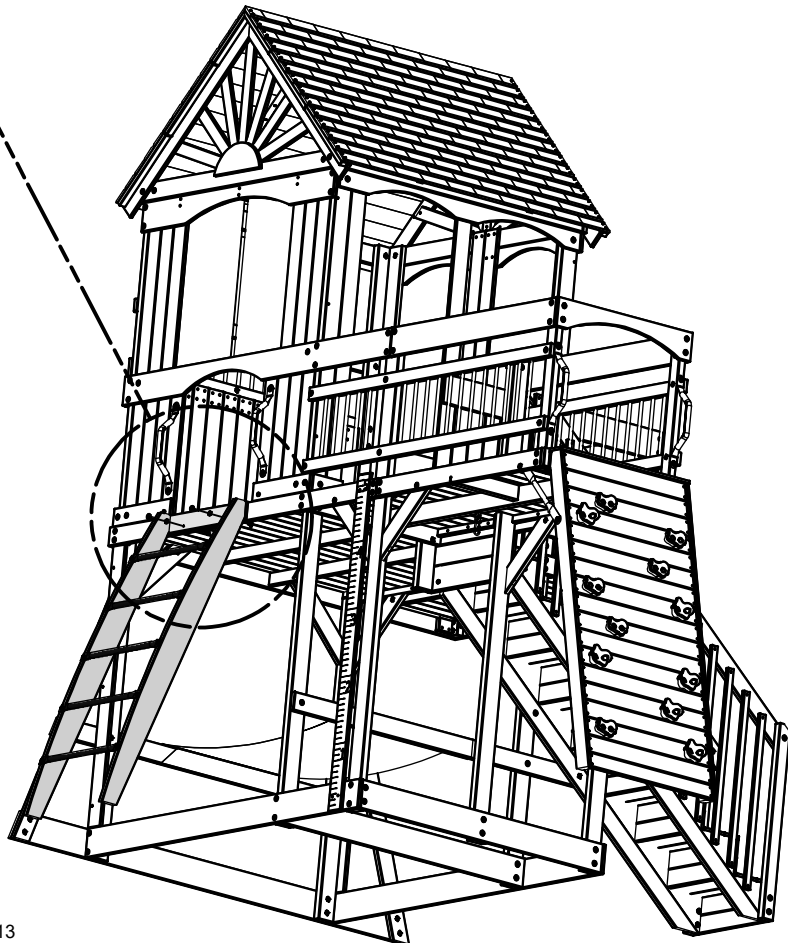
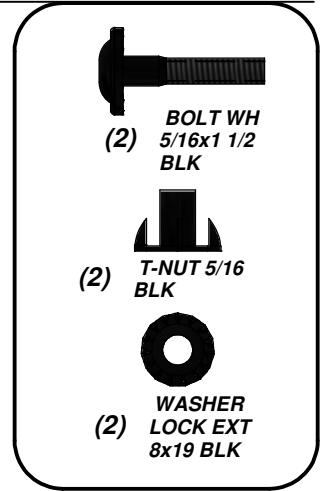

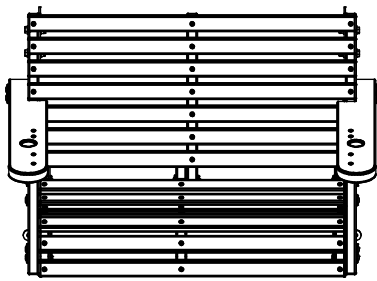

SWING ASSEMBLY

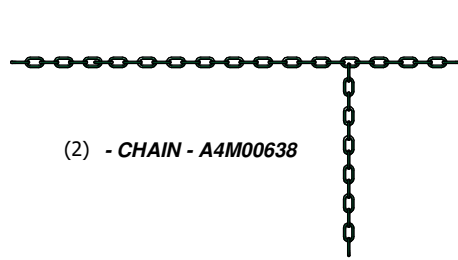

(2) - CHAIN - A4M00638

TOP ATTACHMENT

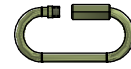

(4) - QUICK LINK - A100069

STEP 74

NOTE:
THE BOTTOM OF THE SWING ASSEMBLY,
TO BE NO LOWER THEN (20 CM) 8 INCHES
FROM THE GROUND.

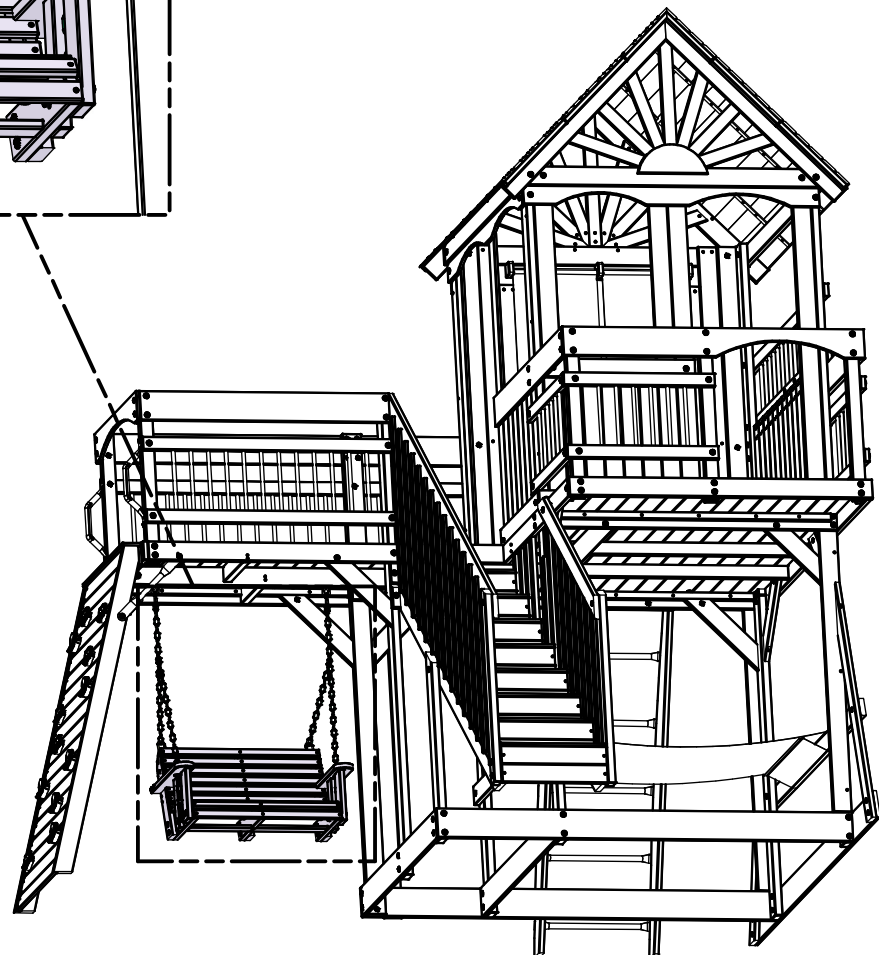
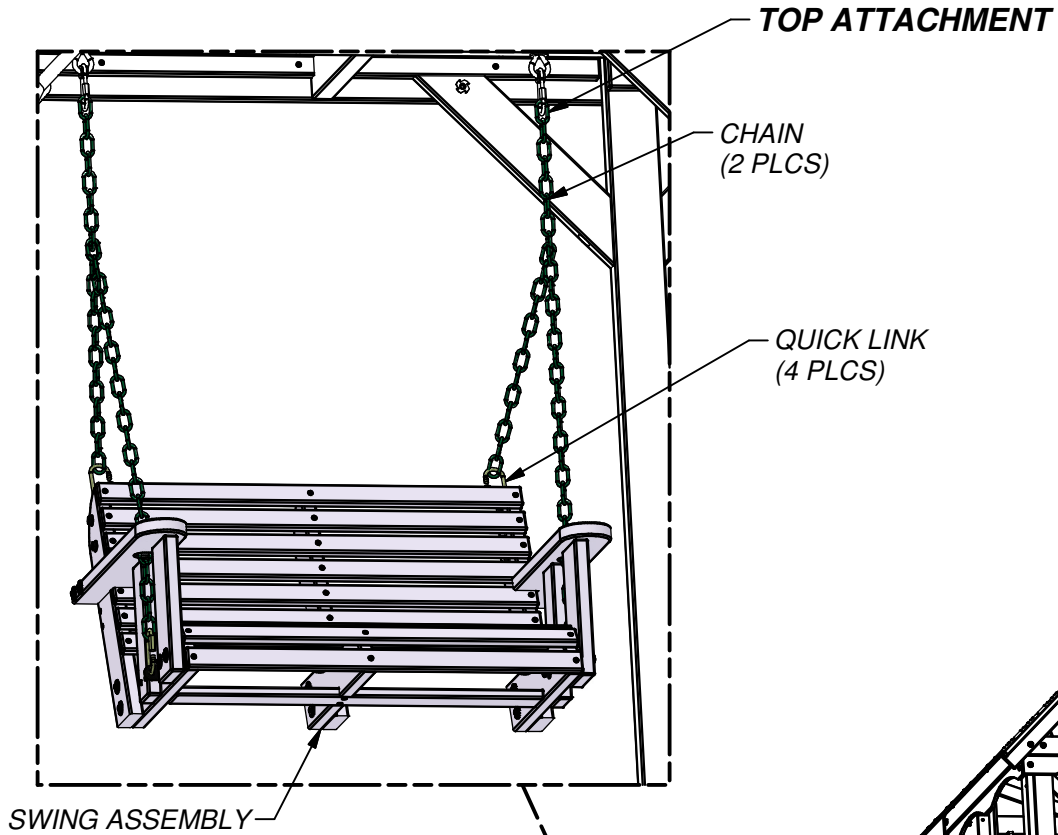

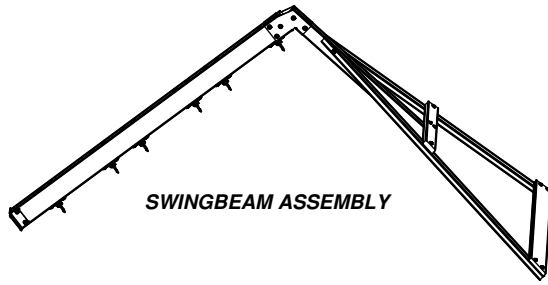

STEP 75

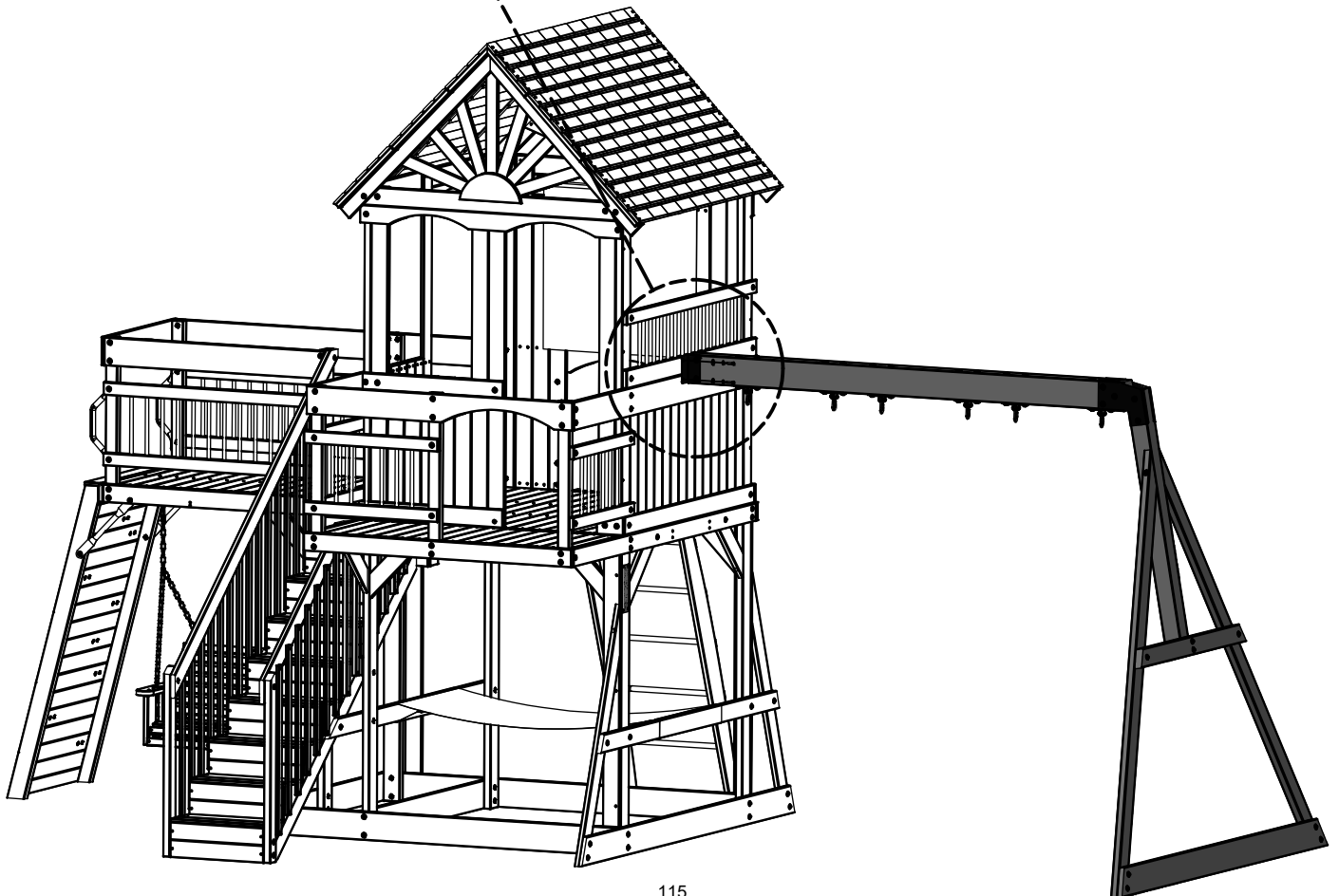
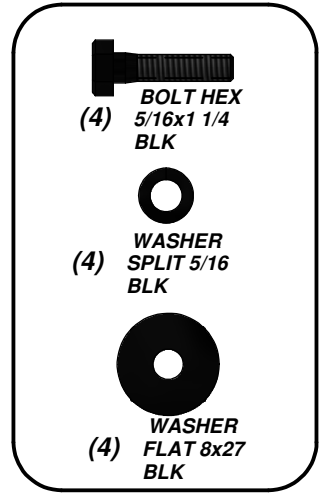
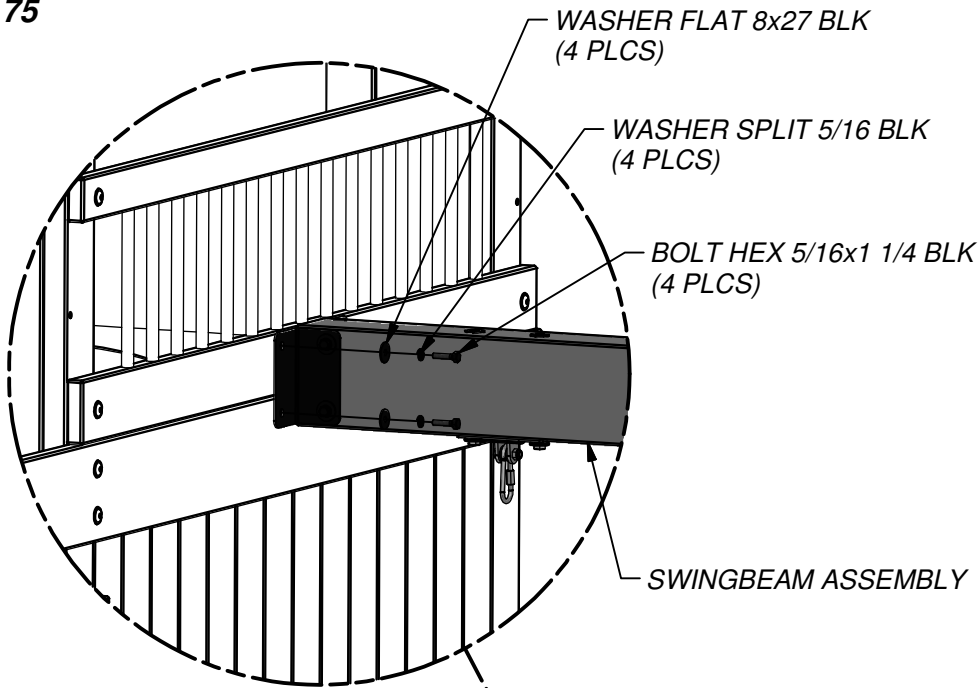



(2) - SWING SEAT GREEN 22" - A6P00054



(6) - QUICK LINK - A100069



(1) - TRAPEZE YELLOW - A6P00034



(4) EF - CHAIN GREEN 57" - A100047



(2) - CHAIN GREEN 31" - A100177

STEP 76

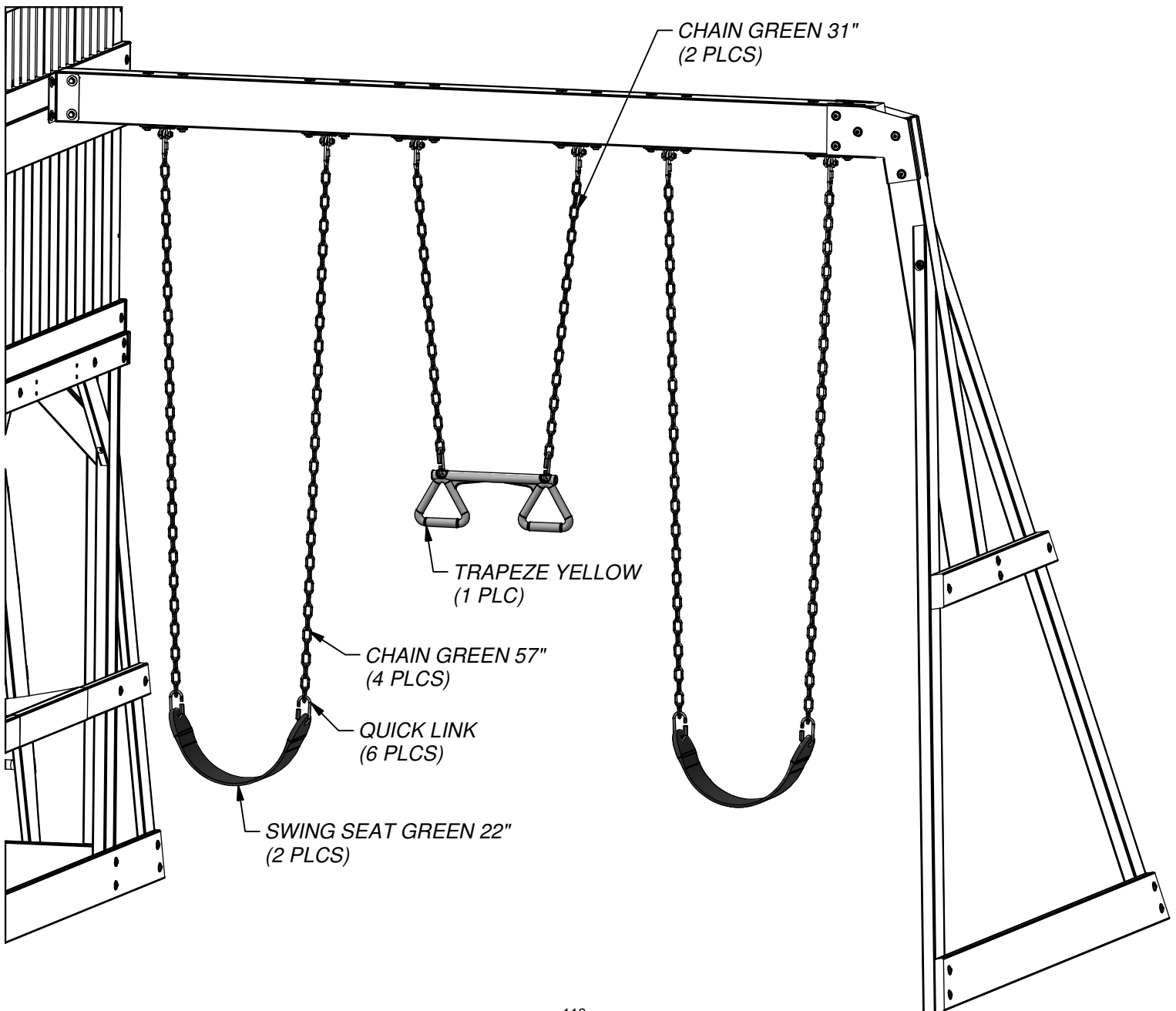

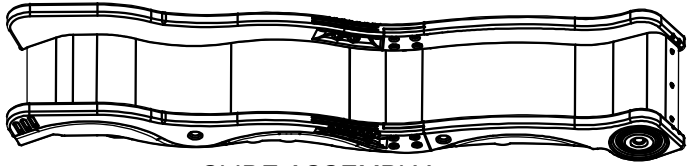





SLIDE ASSEMBLY

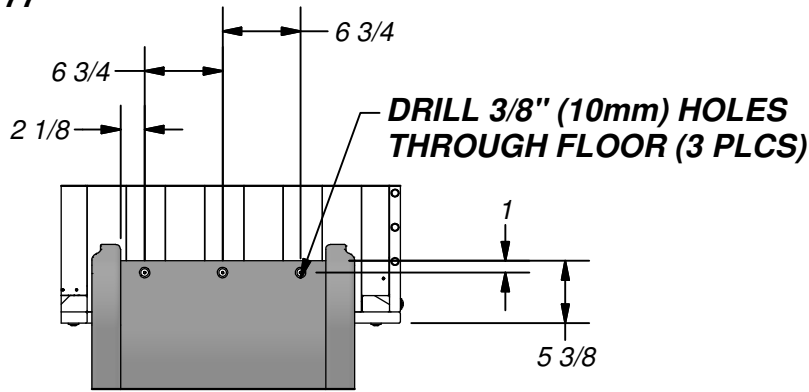

(1) - BYD ID TAG (LARGE) AGES 3-10 - A100164

STEP 77



	
(3) WASHER LOCK EXT 12x19	(3) NUT BARREL WH 5/16x5/8
	
(4) SCREW PFH 8x3/4	(3) BOLT WH 5/16x1/2

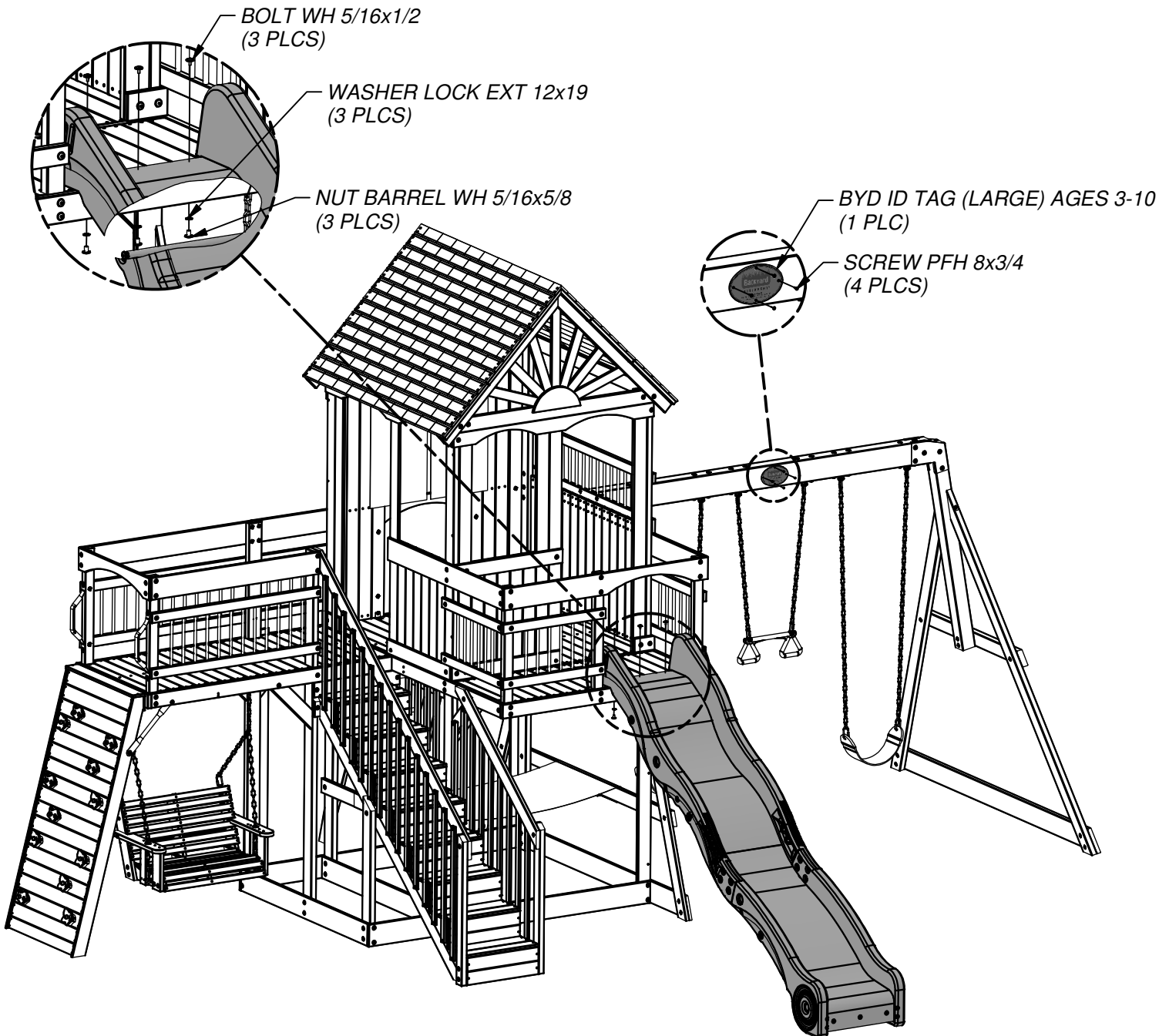



(10) - AUGER GROUND STAKE - A100178

STEP 78

NOTE:
FAILURE TO USE GROUND STAKES CAN
VOID WARRANTY & CAUSE INJURY!

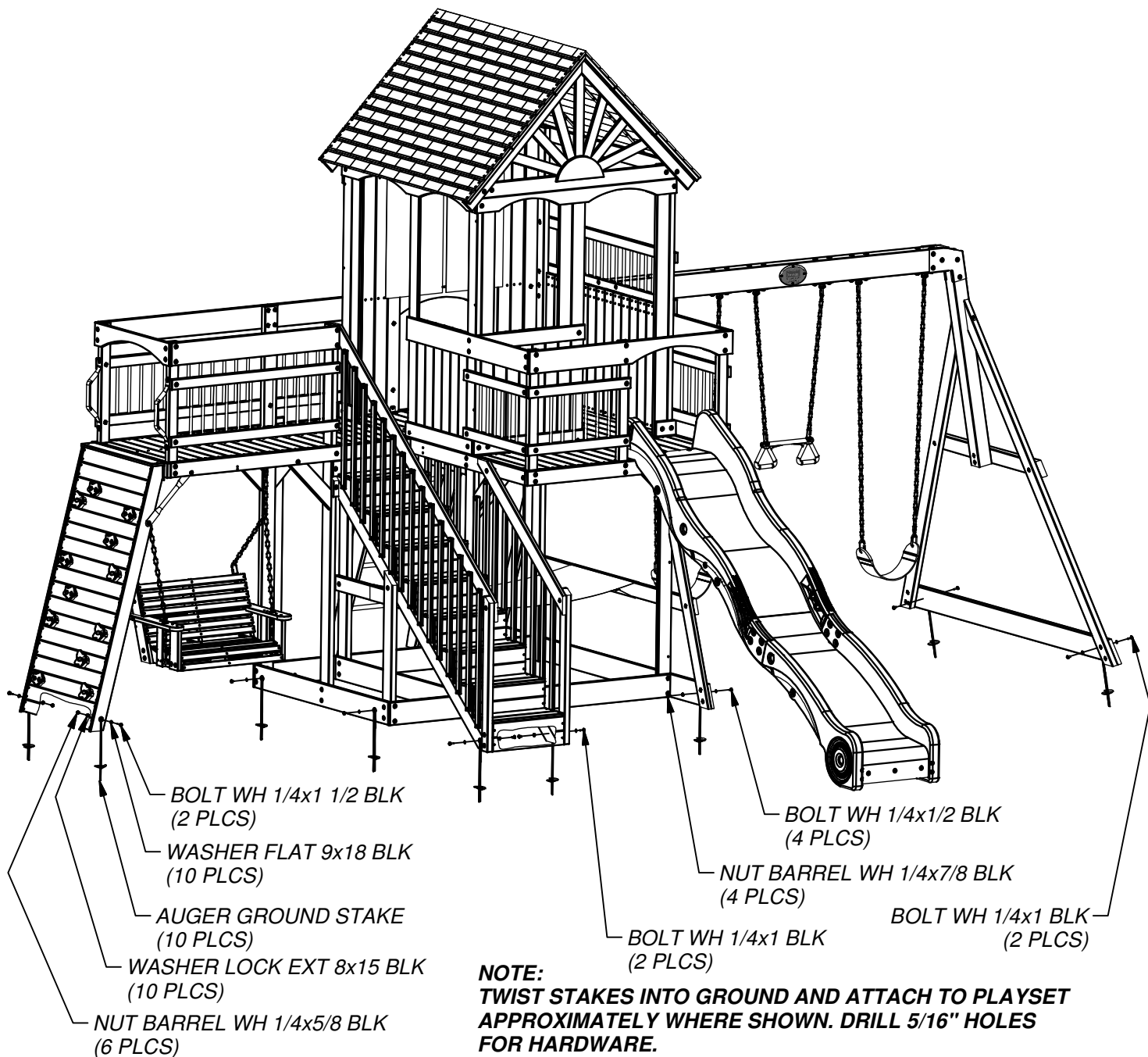
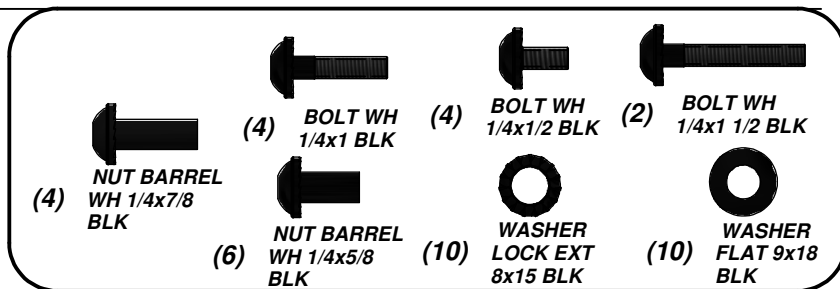

FINAL STEP

DOUBLE CHECK EVERY BOLT, SCREW AND NUT FOR TIGHTNESS. MAKE SURE EVERY BOARD IS SECURE AND MAKE SURE THE PLAY SET IS LEVEL.

ENJOY YOUR NEW PLAY SET!